

Gait[®]

2022

aggiornato al :
release :

20/2022

GAIT srl - Via della Cooperazione, 7 - 40129 Bologna - Italia
Tel. 0039 051 4172011 - Fax 0039 051 4172020

www.gait.it

Copyright 2022
Gait[®] srl
Tutti i diritti riservati



Foto e disegni protetti da diritto d'autore
È vietata ogni riproduzione

Photos and drawings protected by copyright
Any reproduction is prohibited

INDICE DEGLI ATTACCHI INDEX OF SHANKS

CILINDRICO
CYLINDRICAL (DIN 1835)



Pag.
32

TRAPEZIO
TRAPEZOIDAL (DIN 6327)



Pag.
47

DIN 238



Pag.
52

CONO MORSE
MT (DIN 228)



Pag.
54

FAMUP RAG - BIMAK



Pag.
78

BRIDGEPORT R8



Pag.
80

DIN 2080
NT SHANK



Pag.
83

DIN 69871
SK - ISO 7388-1



Pag.
100

BT - MAS 403
BT - JIS-B 6339 / ISO 7388-2



Pag.
128

MANDRINI PER LEGNO E LEGHE LEGGERE
SPINDLES FOR WOOD AND LIGHT ALLOYS



Pag.
217

INDICE DEGLI ATTACCHI INDEX OF SHANKS

HSK A+C

HSK A+C (DIN 69893-1 / ISO 12164-1)



Pag.
156

HSK - T

HSK T (DIN ISO 12164-3)



Pag.
175

HSK E

HSK E (DIN 69893-5 / ISO 12164-1)



Pag.
183

HSK F

HSK F (DIN 69893-6 / ISO 12164-1)



Pag.
190

POLIGONALE

POLYGONAL (DIN ISO 26623-1)



Pag.
198

VDI

VDI (DIN 69880 / ISO 10889)



Pag.
312

PORTAUTENSILI RADIALI

RADIAL TOOLHOLDERS



Pag.
338

PORTAUTENSILI PER INDEX, TRAUB, etc.

TOOLHOLDERS FOR INDEX, TRAUB, etc.

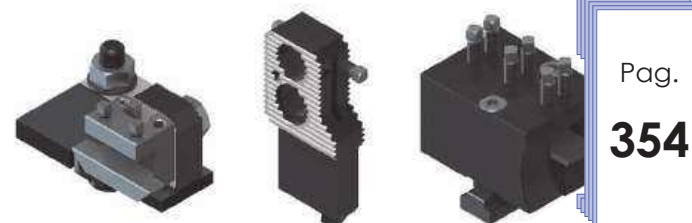

Pag.
354

PORTAGODRONI STELO QUADRO

SQUARE SHANK KNURLING HOLDERS



Pag.
368

INDICE DELLE PINZE INDEX OF COLLETS

PINZE ER - DIN 6499 ER COLLETS (ISO 15488)



Pag.
10

PINZE ETS ETS COLLETS



Pag.
266

PINZE EOC - DIN 6388 EOC COLLETS (ISO 10897)



Pag.
268

PER FORTE SERRAGGIO FOR HIGH GRIP CHUCKS



Pag.
270

PER MANDRINI IDRAULICI FOR HYDRAULIC CHUCKS



Pag.
272

PINZE CONO MORSE MORSE TAPER COLLETS



Pag.
273

PINZE CM CON FILETTO MT COLLETS WITH THREAD



Pag.
273

PINZE DA DA COLLETS



Pag.
274

PINZE TG TG COLLETS



Pag.
274

PINZE BAKUER BAKUER COLLETS



Pag.
275

PINZE 443E 443E COLLETS



Pag.
275

PINZE BRIDGEPORT R8 BRIDGEPORT R8 COLLETS



Pag.
275

PINZE CONO SEMPLICE SINGLE CONE COLLETS



Pag.
277

INDICE DELLE PINZE

INDEX OF COLLETS

PINZE DOPPIO CONO
DOUBLE CONE COLLETS



Pag.

278

TESTE DI CHIUSURA
CLAMPING HEADS



Pag.

279

PINZE CON FILETTO ESTERNO
DRAWBACK COLLETS



Pag.

280

PINZE 5C
5C COLLETS



Pag.

280

CONTROPINZE
FEED FINGERS



Pag.

281

PER CARICATORI CUCCHI
FOR CUCCHI BAR-FEEDER



Pag.

282

PER CARICATORI IEMCA
FOR IEMCA BAR-FEEDER



Pag.

283

PER TOP AUTOMAZIONI
FOR TOP AUTOMAZIONI



Pag.

284

PINZE PER ALTRI CARICATORI
OTHER BAR-FEEDER COLLETS



Pag.

286

GUIDA BARRA CON METALLO DURO

GUIDE BUSHINGS WITH SOLID CARBIDE

REGISTRABILI TIRATE
DRAWN BACK ADJUSTABLE



Pag.

287

REGISTRABILI SPINTE
PUSHED ADJUSTABLE



Pag.

287

FISSE
FIXED TYPE



Pag.

287

INDICE RICAMBI ED ACCESSORI

INDEX OF SPARES AND ACCESORIES

GHIERE ER - DIN 6499
ER NUTS (ISO 15488)



Pag.
27

GHIERE ER CON FILETTO ESTERNO - DIN 6499
OUTSIDE THREAD ER NUTS (ISO 15488)



Pag.
29

CHIAVI ER - DIN 6499
ER WRENCHES



Pag.
30

CHIAVI ER - DINAMOMETRICHE
ER WRENCHES - DYNAMOMETRIC



Pag.
31

CODOLI DI AGGANCIAMENTO
PULL STUDS



Pag.
221

BUSSOLE PORTA MASCHI
TAPPING ADAPTERS



Pag.
235

SMONTACONI ORIENTABILI
ORIENTABLE TIGHTENING FIXTURES



Pag.
240

SUPPORTI DI MONTAGGIO
TIGHTENING FIXTURES

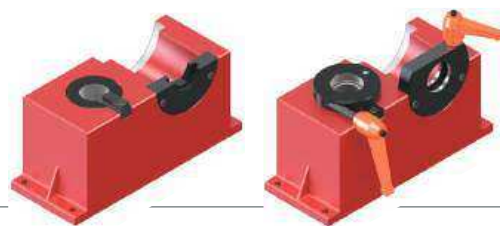

Pag.
242

TAMPONI PULITORI
TAPER CLEANERS



Pag.
243

MAGAZZINI PORTACONI
TOOL STORES



Pag.
244

BUSSOLE DI RIDUZIONE
REDUCTION SLEEVES



Pag.
288

RIDUZIONI PER PORTABARENI
SLEEVES FOR BORING BAR HOLDERS



Pag.
297

INDICE RICAMBI ED ACCESSORI

INDEX OF SPARES AND ACCESORIES

RIDUZIONI WELDON

WELDON REDUCTION SLEEVES



Pag.
43

PROLUNGHE E RIDUZIONI PER FRESE FILETTATE

ADAPTERS FOR THREADED MILLS



Pag.
46

MANDRINI AUTOSERRANTI

KEYLESS DRILL CHUCKS



Pag.
62

RIDUZIONI E PROLUNGHE A CONO MORSE

MT REDUCTIONS AND EXTENTIONS



Pag.
72

CACCIACONI PER CONO MORSE

MT CONE EJECTORS



Pag.
73

CONTROPUNTE A CONO MORSE

MT TAILSTOCKS



Pag.
74

AZZERATORI MAGNETICI

MAGNETIC RESETTERS



Pag.
247

CENTRATORI FLOTTANTI

FLOATING EDGE FINDERS



Pag.
248

CENTRATORI A SFERA

EDGE FINDERS WITH SPHERE



Pag.
250

TASTATORI E CENTRATORI 3D

3D POSITION DETECTORS AND EDGE FINDERS



Pag.
251

UGELLI E PROLUNGHE

NOZZLES AND EXTENSIONS



Pag.
252

DISTANZIALI

SPACERS



Pag.
253

INDICE RICAMBI ED ACCESSORI

INDEX OF SPARES AND ACCESORIES

ADDUTTORI E CHIAVI PER HSK

HSK COOLANT TUBES AND WRENCHES



Pag.
155

RICAMBI PER PORTAFRESA

SPARES FOR MILL HOLDERS



Pag.
254

RICAMBI PER RIDUZIONI A CONO MORSE

SPARES FOR MT ADAPTERS



Pag.
256

GRANI WELDON E VITERIA

WELDON END MILL SCREWS AND OTHERS



Pag.
259

CHIUDIPINZA PNEUMATICI

PNEUMATIC COLLET CHUCKS



Pag.
261

GHIERE E CHIAVI EOC - DIN 6388

EOC NUTS AND WRENCHES



Pag.
269

BROCCE

BROACHES



Pag.
348

UTENSILI SALDOBTRASATI

BRAZED CARBIDE TOOLS



Pag.
366

BARRETTE IN ACCIAIO SUPER RAPIDO

RODS IN HIGH SPEED STEEL



Pag.
367

GODRONI

KNURLING WHEELS



Pag.
369

RICAMBI ED ACCESSORI PER TORNI AUTOMATICI

SPARES AND ACCESSORIE FOR AUTOMATIC LATHES



Pag.
370



Gait[®]

**dal
1960**

INDICE DELLE PINZE ER (DIN 6499 / ISO 15488)

INDEX OF ER COLLETS (DIN 6499 / ISO 15488)

ER - PRECISIONE STANDARD
STANDARD PRECISION TYPE

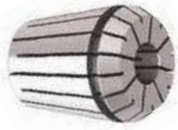

pag. 11

ER HP - DI ALTA PRECISIONE
HIGH PRECISION TYPE

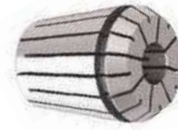

pag. 16

$\leq 0,005$

JET - CON FORI DI REFRIGERAZIONE
WITH COOLANT HOLES



pag. 17

RF - A TENUTA STAGNA
SEALED TYPE

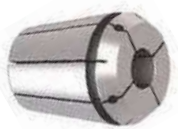

40 bar

pag. 18

UP - A TENUTA STAGNA DI ULTRA PRECISIONE
ULTRA PRECISION SEALED TYPE



40 bar

$\leq 0,005$

pag. 19

SSC - A TENUTA MECCANICA PER ALTE PRESSIONI
STEEL SEALED FOR HIGH PRESSURES



130 bar

pag. 20

SSC HP - A TENUTA MECCANICA DI ALTA PRECISIONE
HIGH PRECISION STEEL SEALED TYPE

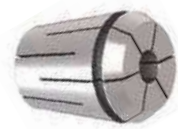

130 bar

$\leq 0,005$

pag. 21

MF - CON QUADRO PER MASCHI
WITH SQUARE FOR TAPS



pag. 22

ML - A TENUTA STAGNA CON QUADRO PER MASCHI
WATERTIGHT WITH SQUARE FOR TAPS



40 bar

pag. 23

AM - COMPENSATE A TRAZIONE
WITH TRACTION COMPENSATION



pag. 24

TAMPONI PULITORI SEDE ER
ER SEAT TAPER CLEANER

pag. 25



GHIERE ER
ER NUTS

pag. 27



CHIAVI ER
ER WRENCHES

pag. 30



DIN 6499/B
ISO 15488 - B

PINZE ER
ER COLLETS

PRECISIONE
RUNOUT

 ≤ 0,010

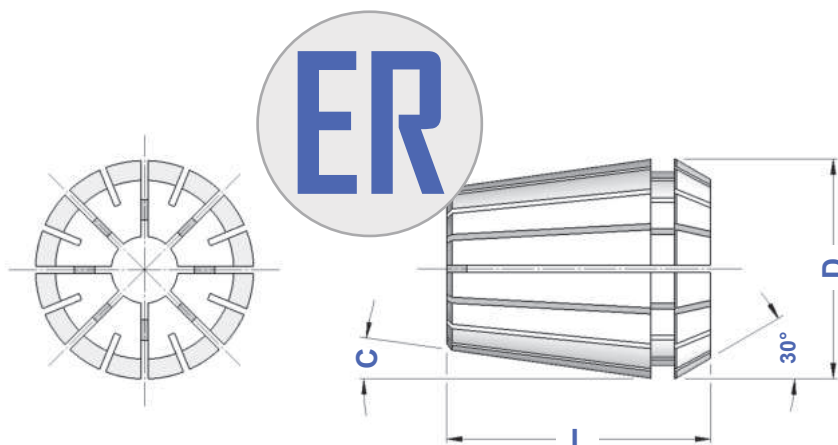

ER



TIPO	Art.	RANGE	SERRAGGIO	STEP	D	L	C	Einheits
ER 8	0554	1 ÷ 5	mm 0,5	0,5	8,5	13,5	8°	4004E
ER 11	5573	1 ÷ 7 OVERSIZE 7,5 ÷ 8	mm 0,5 mm 0,5	0,5	11,5	18,0 OVERSIZE → 15,0	8°	4008E
ER 12	5601	1 ÷ 3 3 ÷ 8	mm 0,5 mm 1,0	0,5	12,0	19,5	8°	424E
ER 16	0364	1 ÷ 3 3 ÷ 10 OVERSIZE 11 ÷ 12	mm 0,5 mm 1,0 mm 0,5	0,5	17,0	27,5 OVERSIZE → 21,5	8°	426E
ER 20	0787	1 ÷ 3 3 ÷ 13 OVERSIZE 14 ÷ 15	mm 0,5 mm 1,0 mm 0,5	0,5	21,0	31,5 OVERSIZE → 26,5	8°	428E
ER 25	0996	1 ÷ 3 3 ÷ 16 OVERSIZE 17 ÷ 20	mm 0,5 mm 1,0 mm 0,5	0,5	26,0	34,0 OVERSIZE → 28,0	8°	430E
ER 32	0988	2 ÷ 20 OVERSIZE 21 ÷ 25	mm 1,0 mm 0,5	0,5	33,0	40,0 OVERSIZE → 34,0	8°	470E
ER 40	0821	3 ÷ 30 OVERSIZE 31 ÷ 32	mm 1,0 mm 0,5	0,5	41,0	46,0 OVERSIZE → 39,5	8°	472E
ER 50	4055	6 ÷ 34 OVERSIZE 35 ÷ 36	mm 1,0 mm 1,0	1,0	52,0	60,0 OVERSIZE 60,0	8°	477E
ER 60	4056	10 ÷ 40	mm 2,0	2,0	61,0	60,0	10°	494E

CONTENITORE VUOTO IN PLASTICA PLASTIC EMPTY TRAY			CASSETTA VUOTA IN LEGNO WOODEN EMPTY BOX			VALIGETTA VUOTA CON SEDE MANDRINO EMPTY CASE WITH SPINDLE SEAT		
PINZA	Art.	n° sedi	Art.	n° sedi	Art.	n° sedi	Art.	n° sedi
ER 8	3672	16	3974	10	3690	16		
ER 11	3673	16	3975	15	3691	16		
ER 12	3673	16	3975	15	3691	16		
ER 16	3674	16	3976	12	3692	16		
ER 20	3675	16	3977	12	3693	16		
ER 25	3676	20	3978	15	7022	28		
ER 32	3677	20	3979	18	7023	28		
ER 40	3678	28	3980	24	7024	28		



PINZE ER - SERIE RIDOTTA
ER COLLETS - REDUCED SET

IN CONFEZIONI
SINGOLE
IN SINGLE PACKS



IN CONTENITORE
di PLASTICA
IN PLASTIC TRAY



IN CASSETTA di LEGNO
IN WOODEN
BOX



TIPO	Diametri	n° pinze	Art.	Art.	Art.
ER 8 Ridotta	Ø 1-2-3-4-5	5	7463	4048	7337
ER 11 Ridotta	Ø 1-2-3-4-5-6-7	7	7464	4049	7338
ER 16 Ridotta	Ø 2-4-6-8-10	5	7465	4050	7339
ER 20 Ridotta	Ø 2-4-6-8-10-12	6	7466	4051	7340
ER 25 Ridotta	Ø 4-6-8-10-12-16	6	7467	4052	7341
ER 32 Ridotta	Ø 4-6-8-10-12-16-20	7	7468	4053	7342
ER 40 Ridotta	Ø 4-6-8-10-12-16-20-25	8	7469	4054	7343



PINZE ER - SERIE COMPLETA
ER COLLETS - COMPLETE SET

IN CONFEZIONI
SINGOLE
IN SINGLE PACKS



IN CONTENITORE
di PLASTICA
IN PLASTIC TRAY



IN CASSETTA di LEGNO
IN WOODEN
BOX



TIPO	Diametri	n° pinze	Art.	Art.	Art.
ER 8 Completa	da Ø 1 a Ø 5 Progressione 0,5	9	7470	4058	7344
ER 11 Completa	da Ø 1 a Ø 7 Progressione 0,5	13	7471	4060	7345
ER 12 Completa	da Ø 1 a Ø 7 Progressione 0,5 - 1	9	7472	4061	7346
ER 16 Completa	da Ø 1 a Ø 10 Progressione 1	10	7473	4062	7347
ER 20 Completa	da Ø 2 a Ø 13 Progressione 1	12	7474	4063	7348
ER 25 Completa	da Ø 2 a Ø 16 Progressione 1	15	7475	4064	7349
ER 32 Completa	da Ø 3 a Ø 20 Progressione 1	18	7476	4065	7350
ER 40 Completa	da Ø 4 a Ø 26 Progressione 1	23	7477	4066	7351



PINZE ER - SERIE CON MISURE OVERSIZE

ER COLLETS - SET WITH OVERSIZE DIAMETERS

IN CONTENITORE
IN PLASTIC TRAY



TIPO	Diametri	STEP	n° pinze	Art.
ER 11 Oversize	da Ø 1 a Ø 8	0,5	15	7352
ER 16 Oversize	da Ø 1 a Ø 12	1	12	7353
ER 20 Oversize	da Ø 2 a Ø 15	1	14	7354
ER 25 Oversize	da Ø 2 a Ø 20	1	19	7355
ER 32 Oversize	da Ø 6 a Ø 25	1	20	7356
ER 40 Oversize	da Ø 6 a Ø 32	1	27	7357



PINZE ER - SERIE INTEGRALE

ER COLLETS - WHOLE SET

IN CONTENITORE
IN PLASTIC TRAY



TIPO	Diametri	n° pinze	Art.
ER 16 Integrale	Ø 1 - 2 - 3 - 4 - 5 - 6 - 7 - 8 - 9 - 10 + Mezze Misure Ø 1,5 - 2,5 - 3,5 - 4,5 - 5,5 - 6,5 - 7,5 - 8,5 - 9,5	19	7746
ER 20 Integrale	Ø 1 - 2 - 3 - 4 - 5 - 6 - 7 - 8 - 9 - 10 - 11 12 - 13 + Mezze Misure Ø 1,5 - 2,5 - 3,5 - 4,5 - 5,5 - 6,5 - 7,5 - 8,5 - 9,5 10,5 - 11,5 - 12,5	25	7747
ER 25 Integrale	Ø 1 - 2 - 3 - 4 - 5 - 6 - 7 - 8 - 9 - 10 - 11 12 - 13 - 14 - 15 - 16 + Mezze Misure Ø 1,5 - 2,5 - 3,5 - 4,5 - 5,5 - 6,5 - 7,5 - 8,5 - 9,5 10,5 - 11,5 - 12,5 - 13,5 - 14,5 - 15,5	31	7748
ER 32 Integrale	Ø 2 - 3 - 4 - 5 - 6 - 7 - 8 - 9 - 10 - 11 - 12 13 - 14 - 15 - 16 - 17 - 18 - 19 - 20 + Mezze Misure Ø 2,5 - 3,5 - 4,5 - 5,5 - 6,5 - 7,5 - 8,5 - 9,5 10,5 - 11,5 - 12,5 - 13,5 - 14,5 - 15,5 - 16,5 17,5 - 18,5 - 19,5	37	7749
ER 40 Integrale	Ø 3 - 4 - 5 - 6 - 7 - 8 - 9 - 10 - 11 - 12 13 - 14 - 15 - 16 - 17 - 18 - 19 - 20 - 21 22 - 23 - 24 - 25 - 26 - 27 - 28 - 29 - 30	28	7750



PINZE ER - SERIE RIDOTTA
IN VALIGETTA CON SEDE MANDRINO
 ER COLLETS - REDUCED SET IN CASE WITH SPINDLE SEAT



TIPO	Diametri	n° pinze	Art.
ER 8 Set - Ridotta	Ø 1-2-3-4-5	5	7487
ER 11 Set - Ridotta	Ø 1-2-3-4-5-6-7	7	7488
ER 16 Set - Ridotta	Ø 2-4-6-8-10	5	7489
ER 20 Set - Ridotta	Ø 2-4-6-8-10-12	6	7490
ER 25 Set - Ridotta	Ø 4-6-8-10-12-16	6	7491
ER 32 Set - Ridotta	Ø 4-6-8-10-12-16-20	7	7492
ER 40 Set - Ridotta	Ø 4-6-8-10-12-16-20-25	8	7493

E' possibile completare tutte le valigette con il portapinza e la chiave di vostro interesse
It is possible to complete all the sets in case with collet chuck and wrench you need



PINZE ER - SERIE COMPLETA
IN VALIGETTA CON SEDE MANDRINO
 ER COLLETS - COMPLETE SET IN CASE WITH SPINDLE SEAT



TIPO	Diametri	n° pinze	Art.
ER 8 Set - Completa	da Ø 1 a Ø 5 Progressione 0,5	9	7551
ER 11 Set - Completa	da Ø 1 a Ø 7 Progressione 0,5	13	7552
ER 12 Set - Completa	da Ø 1 a Ø 7 Progressione 0,5 - 1	9	7599
ER 16 Set - Completa	da Ø 1 a Ø 10 Progressione 1	10	7553
ER 20 Set - Completa	da Ø 2 a Ø 13 Progressione 1	12	7554
ER 25 Set - Completa	da Ø 2 a Ø 16 Progressione 1	15	7555
ER 32 Set - Completa	da Ø 3 a Ø 20 Progressione 1	18	7556
ER 40 Set - Completa	da Ø 4 a Ø 26 Progressione 1	23	7557

E' possibile completare tutte le valigette con il portapinza e la chiave di vostro interesse
It is possible to complete all the sets in case with collet chuck and wrench you need



**PINZE ER - SERIE RIDOTTA E CHIAVE MINI
IN VALIGETTA CON SEDE MANDRINO**

ER COLLETS - REDUCED SET AND MINI WRENCH IN CASE WITH SPINDLE SEAT



KIT	Diametri	n° pinze	Chiave	Art.
ER 8 Ridotta + Chiave Mini	Ø 1-2-3-4-5	5	5717	7751
ER 11 Ridotta + Chiave Mini	Ø 1-2-3-4-5-6-7	7	5718	7752
ER 16 Ridotta + Chiave Mini	Ø 2-4-6-8-10	5	5719	7753
ER 20 Ridotta + Chiave Mini	Ø 2-4-6-8-10-12	6	5720	7754
ER 25 Ridotta + Chiave Mini	Ø 4-6-8-10-12-16	6	5721	7755



**PINZE ER - SERIE COMPLETA E CHIAVE MINI
IN VALIGETTA CON SEDE MANDRINO**

ER COLLETS - COMPLETE SET AND MINI WRENCH IN CASE WITH SPINDLE SEAT



KIT	Diametri	n° pinze	Chiave	Art.
ER 8 Completa + Chiave Mini	da Ø 1 a Ø 5	9	5717	7001
ER 11 Completa + Chiave Mini	da Ø 1 a Ø 7	13	5718	7002
ER 16 Completa + Chiave Mini	da Ø 1 a Ø 10	10	5719	7003
ER 20 Completa + Chiave Mini	da Ø 2 a Ø 13	12	5720	7004
ER 25 Completa + Chiave Mini	da Ø 2 a Ø 16	15	5721	7005



**PINZE ER - SERIE RIDOTTA E CHIAVE STANDARD
IN VALIGETTA CON SEDE MANDRINO**

ER COLLETS - REDUCED SET AND STANDARD WRENCH IN CASE WITH SPINDLE SEAT



KIT	Diametri	n° pinze	Chiave	Art.
ER 16 Ridotta + Chiave Standard	Ø 2-4-6-8-10	5	3698	7495
ER 20 Ridotta + Chiave Standard	Ø 2-4-6-8-10-12	6	3699	7496
ER 25 Ridotta + Chiave Standard	Ø 4-6-8-10-12-16	6	3669	7497
ER 32 Ridotta + Chiave Standard	Ø 4-6-8-10-12-16-20	7	3670	7498
ER 40 Ridotta + Chiave Standard	Ø 4-6-8-10-12-16-20-25	8	3671	7499



**PINZE ER - SERIE COMPLETA E CHIAVE STANDARD
IN VALIGETTA CON SEDE MANDRINO**

ER COLLETS - COMPLETE SET AND STANDARD WRENCH IN CASE WITH SPINDLE SEAT



KIT	Diametri	n° pinze	Chiave	Art.
ER 16 Completa + Chiave Standard	da Ø 1 a Ø 10	10	3698	7536
ER 20 Completa + Chiave Standard	da Ø 2 a Ø 13	12	3699	7537
ER 25 Completa + Chiave Standard	da Ø 2 a Ø 16	15	3669	7538
ER 32 Completa + Chiave Standard	da Ø 3 a Ø 20	18	3670	7539
ER 40 Completa + Chiave Standard	da Ø 4 a Ø 26	23	3671	7540

DIN 6499/B
ISO 15488 - B

PINZE ER DI ALTA PRECISIONE
HIGH PRECISION ER COLLETS

PRECISIONE
RUNOUT

 ≤ 0,005

TIPO	Art.	RANGE	D	L
ER 8 HP	0554 HP	1 ÷ 5	8,5	13,5
ER 11 HP	5573 HP	1 ÷ 7 OVERSIZE 7,5 ÷ 8	11,5	18,0 OVERSIZE → 15,0
ER 16 HP	0364 HP	1 ÷ 10 OVERSIZE 11 ÷ 12	17,0	27,5 OVERSIZE → 21,5
ER 20 HP	0787 HP	1 ÷ 13 OVERSIZE 14 ÷ 15	21,0	31,5 OVERSIZE → 26,5
ER 25 HP	0996 HP	1 ÷ 16 OVERSIZE 17 ÷ 20	26,0	34,0 OVERSIZE → 28,0
ER 32 HP	0988 HP	2 ÷ 20 OVERSIZE 21 ÷ 25	33,0	40,0 OVERSIZE → 34,0
ER 40 HP	0821 HP	3 ÷ 30 OVERSIZE 31 ÷ 32	41,0	46,0 OVERSIZE → 39,5
ER 50 HP	4055 HP	6 ÷ 34 OVERSIZE 35 ÷ 36	52,0	60,0 OVERSIZE 60,0

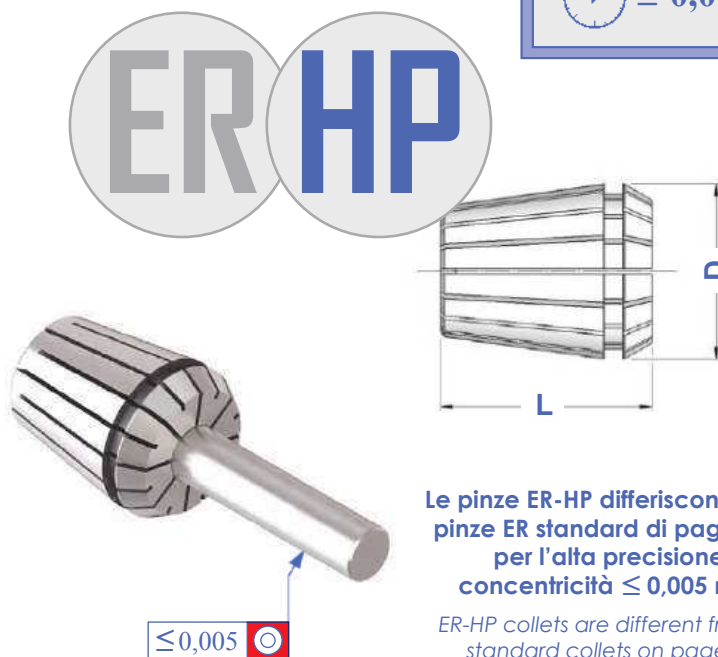

Le pinze ER-HP differiscono dalle pinze ER standard di pagina 11 per l'alta precisione: concentricità ≤ 0,005 mm.

ER-HP collets are different from ER standard collets on page 11 because of the high precision: ≤ 0,005 runout accuracy



SERIE RIDOTTA DI PINZE ER-HP
REDUCED SET OF COLLETS ER-HP TYPE

TIPO	Diametri	n° pinze	Art.	Art.
ER 8 HP - Ridotta	Ø 1-2-3-4-5	5	7558	7572
ER 11 HP - Ridotta	Ø 1-2-3-4-5-6-7	7	7559	7573
ER 16 HP - Ridotta	Ø 2-4-6-8-10	5	7560	7574
ER 20 HP - Ridotta	Ø 2-4-6-8-10-12	6	7561	7575
ER 25 HP - Ridotta	Ø 4-6-8-10-12-16	6	7562	7576
ER 32 HP - Ridotta	Ø 4-6-8-10-12-16-20	7	7563	7577
ER 40 HP - Ridotta	Ø 4-6-8-10-12-16-20-25	8	7564	7578

IN CONTENITORE di PLASTICA
IN PLASTIC TRAY



IN CASSETTA di LEGNO
IN WOODEN BOX



SERIE COMPLETA DI PINZE ER-HP
COMPLETE SET OF COLLETS ER-HP TYPE

TIPO	Diametri	n° pinze	Art.	Art.
ER 8 HP - Completa	da Ø 1 a Ø 5	9	7565	7579
ER 11 HP - Completa	da Ø 1 a Ø 7	13	7566	7580
ER 16 HP - Completa	da Ø 1 a Ø 10	10	7567	7581
ER 20 HP - Completa	da Ø 2 a Ø 13	12	7568	7582
ER 25 HP - Completa	da Ø 2 a Ø 16	15	7569	7583
ER 32 HP - Completa	da Ø 3 a Ø 20	18	7570	7584
ER 40 HP - Completa	da Ø 4 a Ø 26	23	7571	7585

IN CONTENITORE di PLASTICA
IN PLASTIC TRAY



IN CASSETTA di LEGNO
IN WOODEN BOX



DIN 6499/A
ISO 15488 - A

PINZE ER CON FORI DI REFRIGERAZIONE
ER COLLETS WITH COOLANT HOLES

PRECISIONE
RUNOUT

 ≤ 0,010

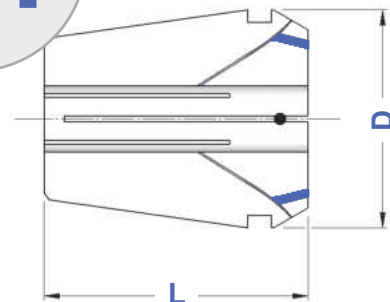
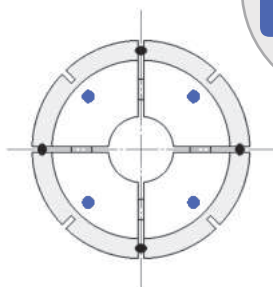
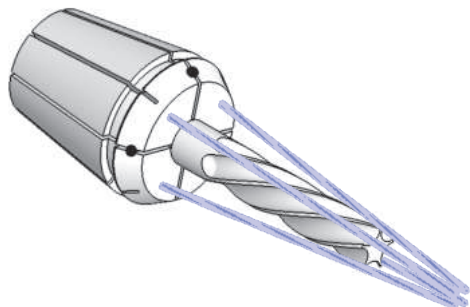

Il refrigerante viene convogliato sui taglienti dell'utensile mediante i fori inclinati.
Pressione di esercizio: fino a 40 Bar / 600 PSI

Coolant is carried towards the edges of the tool through sloped holes.
Working pressure: up to 40 Bar / 600 PSI

TIPO	Art.	RANGE	D	L	STEP
ER 16 JET	0364 JE	3 ÷ 7	17,0	27,5	0,5
ER 20 JET	0787 JE	3 ÷ 9	21,0	31,5	0,5
ER 25 JET	0996 JE	3 ÷ 14	26,0	34,0	0,5
ER 32 JET	0988 JE	3 ÷ 20	33,0	40,0	0,5
ER 40 JET	0821 JE	4 ÷ 26	41,0	46,0	1,0
ER 50 JET	4055 JE	6 ÷ 34	52,0	60,0	1,0



SERIE RIDOTTA DI PINZE ER-JET
REDUCED SET OF COLLETS ER-JET TYPE

TIPO	Diametri	n° pinze	Art.	Art.
ER 25 JET - Ridotta	Ø 4 - 6 - 8 - 10 - 12	5	7637	7647
ER 32 JET - Ridotta	Ø 4 - 6 - 8 - 10 - 12 - 16 - 20	7	7638	7648
ER 40 JET - Ridotta	Ø 4 - 6 - 8 - 10 - 12 - 16 - 20 - 25	8	7639	7649

IN CONTENITORE di PLASTICA
IN PLASTIC TRAY



IN CASSETTA di LEGNO
IN WOODEN BOX



SERIE COMPLETA DI PINZE ER-JET
COMPLETE SET OF COLLETS ER-JET TYPE

TIPO	Diametri	n° pinze	Art.	Art.
ER 16 JET - Completa	da Ø 3 a Ø 7	5	7640	7650
ER 20 JET - Completa	da Ø 3 a Ø 9	7	7641	7651
ER 25 JET - Completa	da Ø 3 a Ø 14	12	7642	7652
ER 32 JET - Completa	da Ø 3 a Ø 20	18	7643	7653
ER 40 JET - Completa	da Ø 4 a Ø 26	23	7644	7654

IN CONTENITORE di PLASTICA
IN PLASTIC TRAY



IN CASSETTA di LEGNO
IN WOODEN BOX



DIN 6499/A
ISO 15488 - A

PINZE ER A TENUTA STAGNA
WATERTIGHT ER COLLETS

PRECISIONE
RUNOUT

 ≤ 0,010

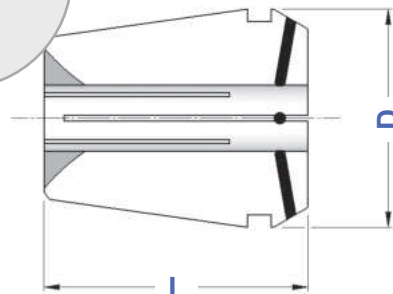
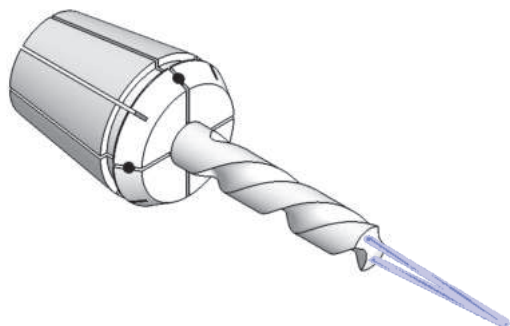

TIPO	Art.	RANGE	D	L	STEP
ER 11 RF	5573 RF	1 ÷ 7	11,5	18,0	0,5
ER 16 RF	0364 RF	1 ÷ 10	17,0	27,5	0,5
ER 20 RF	0787 RF	2 ÷ 13	21,0	31,5	0,5
ER 25 RF	0996 RF	2 ÷ 16	26,0	34,0	0,5
ER 32 RF	0988 RF	3 ÷ 20	33,0	40,0	0,5
ER 40 RF	0821 RF	4 ÷ 26	41,0	46,0	1,0
ER 50 RF	4055 RF	6 ÷ 34	52,0	60,0	1,0

Il refrigerante viene canalizzato esclusivamente nel foro centrale grazie ad inserti in neoprene inseriti nei tagli (a partire da Ø 3).

Pressione di esercizio: fino a 40 Bar / 600 PSI

The coolant is channeled exclusively in the central hole thanks to neoprene insertions into the cuts (starting from Ø 3).

Working pressure: up to 40 Bar / 600 PSI



SERIE RIDOTTA DI PINZE RF
REDUCED SET OF COLLETS RF TYPE

TIPO	Diametri	n° pinze	Art.	Art.
ER 16 RF - Ridotta	Ø 4 - 6 - 8 - 10	4	7587	7600
ER 20 RF - Ridotta	Ø 4 - 6 - 8 - 10 - 12	5	7588	7601
ER 25 RF - Ridotta	Ø 4 - 6 - 8 - 10 - 12 - 16	6	7589	7602
ER 32 RF - Ridotta	Ø 4 - 6 - 8 - 10 - 12 - 16 - 20	7	7590	7603
ER 40 RF - Ridotta	Ø 4 - 6 - 8 - 10 - 12 - 16 - 20 - 25	8	7591	7604

IN CONTENITORE di PLASTICA
IN PLASTIC TRAY



Art.

IN CASSETTA di LEGNO
IN WOODEN BOX



Art.



SERIE COMPLETA DI PINZE RF
COMPLETE SET OF COLLETS RF TYPE

TIPO	Diametri	n° pinze	Art.	Art.
ER 16 RF - Completa	da Ø 3 a Ø 10	8	7593	7606
ER 20 RF - Completa	da Ø 3 a Ø 13	11	7594	7607
ER 25 RF - Completa	da Ø 3 a Ø 16	14	7595	7608
ER 32 RF - Completa	da Ø 3 a Ø 20	18	7596	7609
ER 40 RF - Completa	da Ø 4 a Ø 26	23	7597	7610

IN CONTENITORE di PLASTICA
IN PLASTIC TRAY



Art.

IN CASSETTA di LEGNO
IN WOODEN BOX



Art.

DIN 6499/A
ISO 15488 - A

PINZE ER A TENUTA STAGNA DI ULTRA PRECISIONE

ULTRA PRECISION WATERTIGHT ER COLLETS

PRECISIONE

RUNOUT

 ≤ 0,005

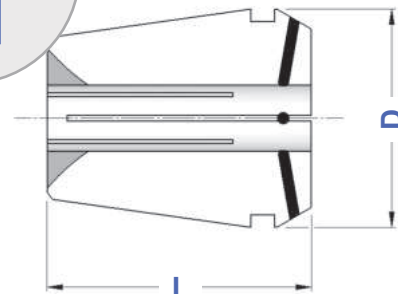
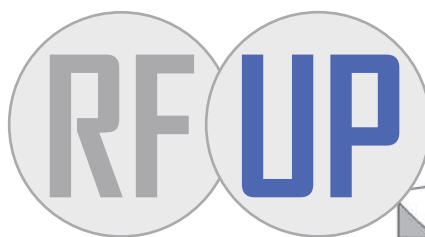
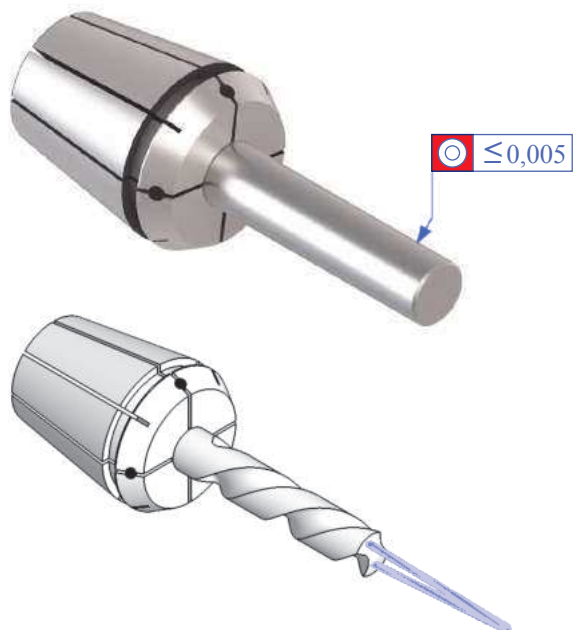

TIPO	Art.	RANGE	D	L	STEP
ER 11 RF - UP	5573 UP	1 ÷ 7	11,5	18,0	0,5
ER 16 RF - UP	0364 UP	1 ÷ 10	17,0	27,5	0,5
ER 20 RF - UP	0787 UP	2 ÷ 13	21,0	31,5	0,5
ER 25 RF - UP	0996 UP	2 ÷ 16	26,0	34,0	0,5
ER 32 RF - UP	0988 UP	3 ÷ 20	33,0	40,0	0,5
ER 40 RF - UP	0821 UP	4 ÷ 26	41,0	46,0	1,0
ER 50 RF - UP	4055 UP	6 ÷ 34	52,0	60,0	1,0

Pinze con le medesime caratteristiche delle RF ma di altissima precisione: concentricità ≤ 0,005 mm. Pressione di esercizio: fino a 40 Bar / 600 PSI

Collets with the same features of RF type but with an ultra precision: ≤ 0,005 runout accuracy. Working pressure: up to 40 Bar / 600 PSI

IN CONTENITORE di PLASTICA
IN PLASTIC TRAY



Art.

IN CASSETTA di LEGNO
IN WOODEN BOX



Art.



SERIE RIDOTTA DI PINZE RF-UP

REDUCED SET OF COLLETS RF-UP TYPE

TIPO	Diametri	n° pinze	Art.	Art.
ER 16 UP - Ridotta	Ø 4 - 6 - 8 - 10	4	7612	7624
ER 20 UP - Ridotta	Ø 4 - 6 - 8 - 10 - 12	5	7613	7625
ER 25 UP - Ridotta	Ø 4 - 6 - 8 - 10 - 12 - 16	6	7614	7626
ER 32 UP - Ridotta	Ø 4 - 6 - 8 - 10 - 12 - 16 - 20	7	7615	7627
ER 40 UP - Ridotta	Ø 4 - 6 - 8 - 10 - 12 - 16 - 20 - 25	8	7616	7628



SERIE COMPLETA DI PINZE RF-UP

COMPLETE SET OF COLLETS RF-UP TYPE

TIPO	Diametri	n° pinze	Art.	Art.
ER 16 UP - Completa	da Ø 3 a Ø 10	8	7618	7630
ER 20 UP - Completa	da Ø 3 a Ø 13	11	7619	7631
ER 25 UP - Completa	da Ø 3 a Ø 16	14	7620	7632
ER 32 UP - Completa	da Ø 3 a Ø 20	18	7621	7633
ER 40 UP - Completa	da Ø 4 a Ø 26	23	7622	7634

IN CONTENITORE di PLASTICA
IN PLASTIC TRAY



Art.

IN CASSETTA di LEGNO
IN WOODEN BOX



Art.

DIN 6499/B
ISO 15488 - B

**PINZE ER STAGNE A TENUTA MECCANICA
PER ALTE PRESSIONI**

STEEL SEALED ER COLLETS FOR HIGH PRESSURES

**PRECISIONE
RUNOUT**

 ≤ 0,010

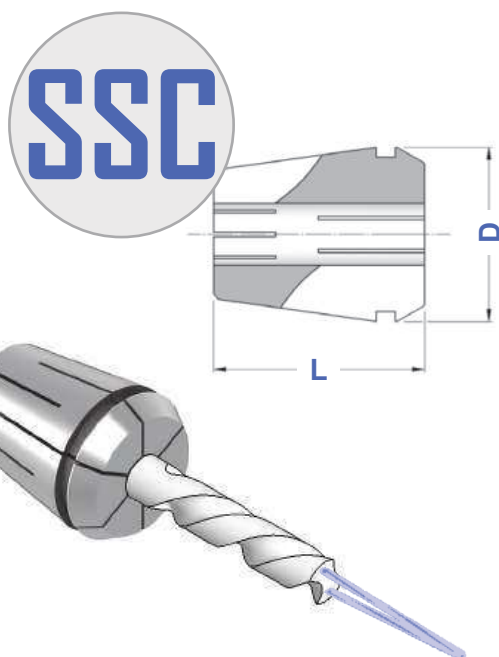

Il refrigerante viene canalizzato esclusivamente nel foro centrale grazie alla tenuta meccanica garantita dalla conformazione dei tagli.

Pressione di esercizio: fino a 130 Bar / 1900 PSI

The coolant is channeled exclusively in the central hole thanks to the mechanical seal guaranteed by the cuts conformation.
Working pressure: up to 130 Bar / 1900 PSI

TIPO	Art.	RANGE	D	L	STEP
ER 11 SSC	5573 SC	3 ÷ 7 OVERSIZE 7,5 ÷ 8	11,5	18,0 OVERSIZE → 15,0	0,5
ER 16 SSC	0364 SC	3 ÷ 10 OVERSIZE 11 ÷ 12	17,0	27,5 OVERSIZE → 21,5	0,5
ER 20 SSC	0787 SC	3 ÷ 13 OVERSIZE 14 ÷ 15	21,0	31,5 OVERSIZE → 26,5	0,5
ER 25 SSC	0996 SC	3 ÷ 16 OVERSIZE 17 ÷ 20	26,0	34,0 OVERSIZE → 28,0	0,5
ER 32 SSC	0988 SC	3 ÷ 20 OVERSIZE 21 ÷ 25	33,0	40,0 OVERSIZE → 34,0	0,5
ER 40 SSC	0821 SC	3 ÷ 30 OVERSIZE 31 ÷ 32	41,0	46,0 OVERSIZE → 39,5	1,0



SERIE RIDOTTA DI PINZE ER-SSC
REDUCED SET OF COLLETS ER-SSC TYPE

TIPO	Diametri	n° pinze	Art.	Art.
ER 16 SSC - Ridotta	Ø 4 - 6 - 8 - 10	4	7670	7690
ER 20 SSC - Ridotta	Ø 4 - 6 - 8 - 10 - 12	5	7671	7691
ER 25 SSC - Ridotta	Ø 4 - 6 - 8 - 10 - 12 - 16	6	7672	7692
ER 32 SSC - Ridotta	Ø 4 - 6 - 8 - 10 - 12 - 16 - 20	7	7673	7693
ER 40 SSC - Ridotta	Ø 4 - 6 - 8 - 10 - 12 - 16 - 20 - 25	8	7674	7694

**IN CONTENITORE
di PLASTICA**
IN PLASTIC TRAY



Art.

IN CASSETTA di LEGNO
IN WOODEN
BOX



Art.



SERIE COMPLETA DI PINZE ER-SSC
COMPLETE SET OF COLLETS ER-SSC TYPE

TIPO	Diametri	n° pinze	Art.	Art.
ER 16 SSC - Completa	da Ø 3 a Ø 10	8	7675	7695
ER 20 SSC - Completa	da Ø 3 a Ø 13	11	7676	7696
ER 25 SSC - Completa	da Ø 3 a Ø 16	14	7677	7697
ER 32 SSC - Completa	da Ø 3 a Ø 20	18	7678	7698
ER 40 SSC - Completa	da Ø 4 a Ø 26	23	7679	7699

**IN CONTENITORE
di PLASTICA**
IN PLASTIC TRAY



Art.

IN CASSETTA di LEGNO
IN WOODEN
BOX



Art.

DIN 6499/B
ISO 15488 - B

**PINZE ER STAGNE A TENUTA MECCANICA
PER ALTE PRESSIONI - VERSIONE HP**
HIGH PRECISION STEEL SEALED ER COLLETS FOR HIGH PRESSURES

**PRECISIONE
RUNOUT**

 ≤ 0,005



Pinze con le medesime caratteristiche delle SSC di tenuta meccanica del refrigerante, ma di elevata precisione: concentricità ≤ 0,005 mm. Pressione di esercizio: fino a 130 Bar / 1900 PSI

Collets with the same cooling mechanical seal features of SSC type, but with an high precision: ≤ 0,005 runout accuracy. Working pressure: up to 130 Bar / 1900 PSI

TIPO	Art.	RANGE	D	L
ER 11 SSC - HP	5573 SH	3 ÷ 7 OVERSIZE 7,5 ÷ 8	11,5	18,0 OVERSIZE → 15,0
ER 16 SSC - HP	0364 SH	3 ÷ 10 OVERSIZE 11 ÷ 12	17,0	27,5 OVERSIZE → 21,5
ER 20 SSC - HP	0787 SH	3 ÷ 13 OVERSIZE 14 ÷ 15	21,0	31,5 OVERSIZE → 26,5
ER 25 SSC - HP	0996 SH	3 ÷ 16 OVERSIZE 17 ÷ 20	26,0	34,0 OVERSIZE → 28,0
ER 32 SSC - HP	0988 SH	3 ÷ 20 OVERSIZE 21 ÷ 25	33,0	40,0 OVERSIZE → 34,0
ER 40 SSC - HP	0821 SH	3 ÷ 30 OVERSIZE 31 ÷ 32	41,0	46,0 OVERSIZE → 39,5



SERIE RIDOTTA DI PINZE SSC-HP
REDUCED SET OF COLLETS SSC-HP TYPE

TIPO	Diametri	n° pinze	Art.	Art.
ER 16 SH - Ridotta	Ø 4-6-8-10	4	7360	7370
ER 20 SH - Ridotta	Ø 4-6-8-10-12	5	7361	7371
ER 25 SH - Ridotta	Ø 4-6-8-10-12-16	6	7362	7372
ER 32 SH - Ridotta	Ø 4-6-8-10-12-16-20	7	7363	7373
ER 40 SH - Ridotta	Ø 4-6-8-10-12-16-20-25	8	7364	7374

**IN CONTENITORE
di PLASTICA**
IN PLASTIC TRAY



IN CASSETTA di LEGNO
IN WOODEN
BOX



SERIE COMPLETA DI PINZE SSC-HP
COMPLETE SET OF COLLETS SSC-HP TYPE

TIPO	Diametri	n° pinze	Art.	Art.
ER 16 SH - Completa	da Ø 3 a Ø 10	8	7365	7375
ER 20 SH - Completa	da Ø 3 a Ø 13	11	7366	7376
ER 25 SH - Completa	da Ø 3 a Ø 16	14	7367	7377
ER 32 SH - Completa	da Ø 3 a Ø 20	18	7368	7378
ER 40 SH - Completa	da Ø 4 a Ø 26	23	7369	7379

**IN CONTENITORE
di PLASTICA**
IN PLASTIC TRAY



IN CASSETTA di LEGNO
IN WOODEN
BOX



DIN 6499/A
ISO 15488 - A

PINZE ER CON QUADRO PER MASCHIATURA
ER COLLETS WITH SQUARE FOR TAPPING

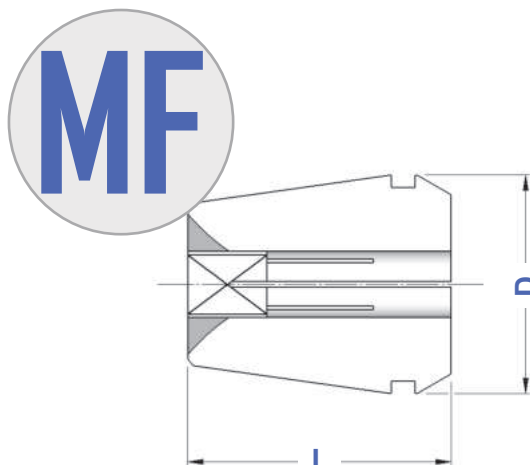

TIPO	Art.	RANGE	D	L
ER 11 MF - con Quadro	5573 MF	∅ 3,5 ÷ ∅ 6,0	11,5	18,0
ER 16 MF - con Quadro	0364 MF	∅ 3,5 ÷ ∅ 8,0	17,0	27,5
ER 20 MF - con Quadro	0787 MF	∅ 3,5 ÷ ∅ 10,0	21,0	31,5
ER 25 MF - con Quadro	0996 MF	∅ 3,5 ÷ ∅ 12,0	26,0	34,0
ER 32 MF - con Quadro	0988 MF	∅ 3,5 ÷ ∅ 16,0	33,0	40,0
ER 40 MF - con Quadro	0821 MF	∅ 4,5 ÷ ∅ 20,0	41,0	46,0
ER 50 MF - con Quadro	4055 MF	∅ 8,0 ÷ ∅ 32,0	52,0	60,0

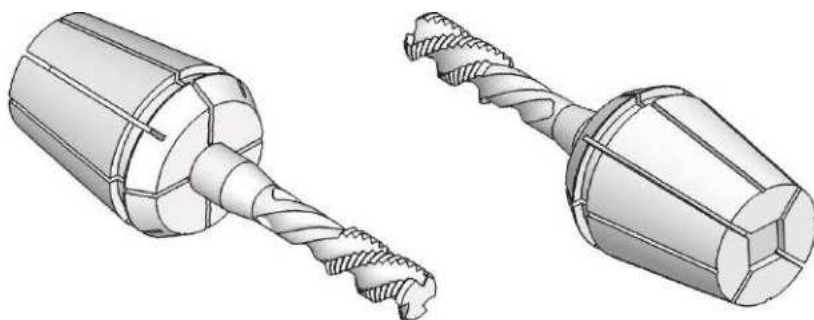

Il quadro di trascinamento per il maschio è ricavato sul fondo della pinza.

The drag square for the tapping tool is made on the bottom of the collet.



SERIE RIDOTTA DI PINZE ER-MF
REDUCED SET OF COLLETS ER-MF TYPE

TIPO	Diametri	n° pinze
ER 16 MF - Ridotta	∅ 3,5 - 4,5 - 6 - 7	4
ER 20 MF - Ridotta	∅ 3,5 - 4,5 - 6 - 7 - 8 - 9 - 10	7
ER 25 MF - Ridotta	∅ 3,5 - 4,5 - 6 - 7 - 8 - 9 - 10 - 11 - 12	9
ER 32 MF - Ridotta	∅ 4,5 - 6 - 7 - 8 - 9 - 10 - 11 - 12 - 14 - 16	10
ER 40 MF - Ridotta	∅ 6 - 7 - 8 - 9 - 10 - 11 - 12 - 14 - 16 - 18 - 20	11

IN CONTENITORE di PLASTICA
IN PLASTIC TRAY



Art.

7655

IN CASSETTA di LEGNO
IN WOODEN BOX



Art.

7660

DIN 6499/A
ISO 15488 - A

PINZE ER CON QUADRO PER MASCHIATURA - A TENUTA STAGNA

WATERTIGHT ER COLLETS WITH SQUARE FOR TAPPING

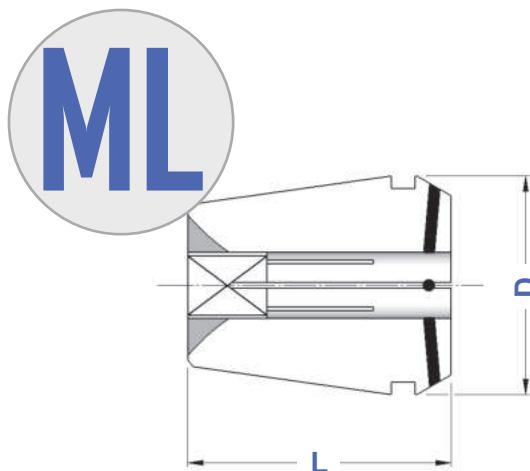

TIPO	Art.	RANGE	D	L
ER 11 ML - con Quadro	5573 ML	∅ 3,5 ÷ ∅ 6,0	11,5	18,0
ER 16 ML - con Quadro	0364 ML	∅ 3,5 ÷ ∅ 8,0	17,0	27,5
ER 20 ML - con Quadro	0787 ML	∅ 3,5 ÷ ∅ 10,0	21,0	31,5
ER 25 ML - con Quadro	0996 ML	∅ 3,5 ÷ ∅ 12,0	26,0	34,0
ER 32 ML - con Quadro	0988 ML	∅ 3,5 ÷ ∅ 16,0	33,0	40,0
ER 40 ML - con Quadro	0821 ML	∅ 4,5 ÷ ∅ 20,0	41,0	46,0
ER 50 ML - con Quadro	4055 ML	∅ 8,0 ÷ ∅ 32,0	52,0	60,0

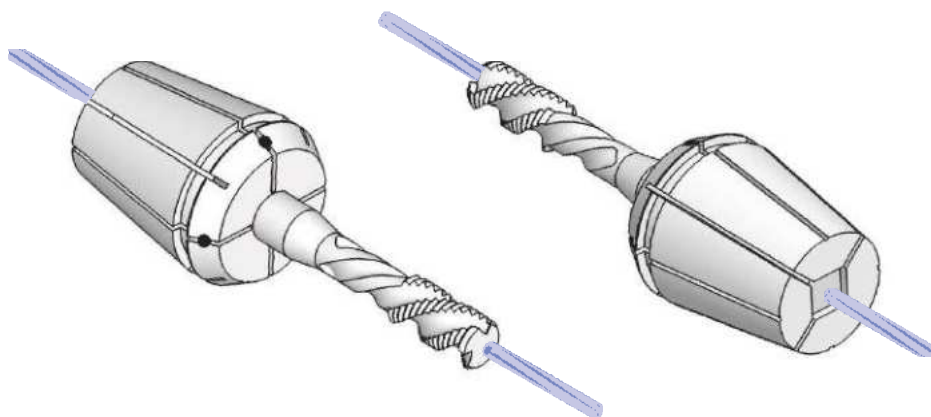

**Il quadro di trascinamento per il maschio è ricavato sul fondo della pinza.
Il refrigerante viene canalizzato esclusivamente nel foro centrale grazie ad inserti in neoprene inseriti nei tagli
Pressione di esercizio: max 40 Bar / 600 PSI**

*The drag square for the tapping tool is made on the bottom of the collet.
The coolant is channeled exclusively in the central hole thanks to neoprene insertions into the cuts.
Working pressure: max 40 Bar / 600 PSI*

IN CONTENITORE di PLASTICA
IN PLASTIC TRAY



Art.

IN CASSETTA di LEGNO
IN WOODEN BOX



Art.

ML

SERIE RIDOTTA DI PINZE ER-ML
REDUCED SET OF COLLETS ER-ML TYPE

TIPO	Diametri	n° pinze	Art.	Art.
ER 16 ML - Ridotta	∅ 3,5 - 4,5 - 6 - 7	4	7756	7761
ER 20 ML - Ridotta	∅ 3,5 - 4,5 - 6 - 7 - 8 - 9 - 10	7	7757	7762
ER 25 ML - Ridotta	∅ 3,5 - 4,5 - 6 - 7 - 8 - 9 - 10 - 11 - 12	9	7758	7763
ER 32 ML - Ridotta	∅ 4,5 - 6 - 7 - 8 - 9 - 10 - 11 - 12 - 14 - 16	10	7759	7764
ER 40 ML - Ridotta	∅ 6 - 7 - 8 - 9 - 10 - 11 - 12 - 14 - 16 - 18 - 20	11	7760	7765

DIN 6499
ISO 15488

PINZE ER - COMPENSATE A TRAZIONE
ER COLLETS - COMPENSATION WITH TRACTION

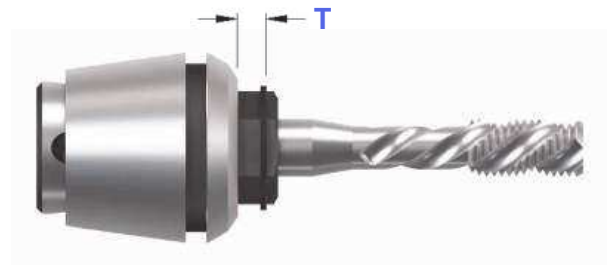
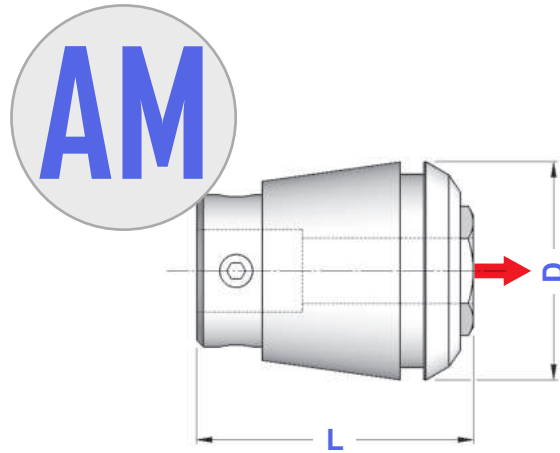

TIPO	Art.	RANGE	D	L	T	C
ER 16 - Compensate	0364 AM	∅ 2,0 ÷ ∅ 6,0	17,0	27,0	7,0	9395
ER 20 - Compensate	0787 AM	∅ 2,5 ÷ ∅ 7,0	21,0	31,0	7,0	9396
ER 25 - Compensate	0996 AM	∅ 2,5 ÷ ∅ 10,0	26,0	34,0	8,0	9397
ER 32 - Compensate	0988 AM	∅ 4,5 ÷ ∅ 12,5	33,0	43,0	10,0	9398
ER 40 - Compensate	0821 AM	∅ 6,0 ÷ ∅ 16,0	41,0	54,0	13,0	9399

Il maschio viene bloccato con i grani situati sulla parte mobile.

Tapping tool is clamped by the screws placed on the mobile part.



CASSETTA CON SERIE RIDOTTA DI PINZE ER-AM
BOX WITH REDUCED SET OF COLLETS ER-AM TYPE



TIPO	Diametri	n° pinze	Art.
ER 16 AM- Ridotta	∅ 2,5 - 2,8 - 3,5 - 4,5 - 6	5	7741
ER 20 AM- Ridotta	∅ 2,5 - 2,8 - 3,5 - 4,5 - 6 - 7	6	7742
ER 25 AM- Ridotta	∅ 3,5 - 4,5 - 6 - 7 - 8 - 9 - 10	7	7743
ER 32 AM- Ridotta	∅ 4,5 - 6 - 7 - 8 - 9 - 10 - 11 - 12	8	7744
ER 40 AM- Ridotta	∅ 6 - 7 - 8 - 9 - 10 - 11 - 12 - 14 - 16	9	7745 *

* Forniti in valigetta di plastica art. 7024

* Supplied into plastic case code 7024

DIMENSIONAMENTO GAMBI PER MASCHI METRICI

SHANKS DIMENSIONS FOR METRIC TAPPING TOOLS

GAMBO ∅ x □	NORMALE DIN 352	RINFORZATO DIN 371	NORMALE DIN 376	NORMALE ISO	RINFORZATO ISO
2,50 x 2,10	M 1,0 ÷ M 1,8	M 1,0 ÷ M 1,8	M 3,5		
2,80 x 2,10	M 2,0 ÷ M 2,5	M 2,0 ÷ M 2,5	M 4,0		
3,15 x 2,50				M 4,0	M 3,0
3,50 x 2,70	M 3,0	M 3,0	M 5,0		
3,55 x 2,80				M 4,5	M 3,5
4,00 x 3,15	M 3,5	M 3,5		M 5,0	M 4,0
4,50 x 3,40	M 4,0	M 4,0	M 6,0		
5,00 x 4,00					M 5,0
5,50 x 4,30			M 7,0		
5,60 x 4,50				M 7,0	
6,00 x 4,90	M 5,0 - M 6,0 - M 8,0	M 5,0 - M 6,0	M 8,0		
6,30 x 5,00				M 8,0	M 6,0
7,00 x 5,50	M 10,0		M 10,0		
7,10 x 5,60				M 9,0	
8,00 x 6,20		M 8,0		M 10,0	M 8,0
9,00 x 7,00	M 12,0		M 12,0	M 12,0	
10,00 x 8,00		M 10,0			M 10,0
11,00 x 9,00	M 14,0		M 14,0		
11,20 x 9,00				M 14,0	
12,00 x 9,00	M 16,0		M 16,0		
12,50 x 10,00				M 16,0	
14,00 x 11,00	M 18,0		M 18,0		
16,00 x 12,00	M 20,0		M 20,0		
18,00 x 14,50	M 22,0 - M 24,0		M 22,0 - M 24,0		
20,00 x 16,00	M 27,0		M 27,0	M 27,0 - M 30,0	
22,00 x 18,00	M 30,0		M 30,0		
25,00 x 20,00	M 33,0		M 33,0	M 36,0	
28,00 x 22,00	M 36,0		M 36,0		
32,00 x 24,00	M 39,0 - M 42,0		M 39,0 - M 42,0		

TP-ER**TAMPONI PULITORI per SEDE PINZA ER**



ER COLLET SEAT TAPER CLEANERS



SEDE ER	Art.
TP - ER 16	5375
TP - ER 20	5376
TP - ER 25	5377
TP - ER 32	5378
TP - ER 40	5379

FILETTI INTERNI DELLE GHIERE ER

ER NUTS INNER THREADS

GHIERA	ER 8	ER 11	ER 16	ER 20	ER 25	ER 32	ER 40	ER 50	ER 60	ER 90
 MINI	10 x 0,75	13 x 0,75	19 x 1,0	24 x 1,0	30 x 1,0					
 ESAGONALE		14 x 0,75	22 x 1,5	25 x 1,5						
 STANDARD			22 x 1,5	25 x 1,5	32 x 1,5	40 x 1,5	50 x 1,5	64 x 2,0	70 x 1,5	110 x 1,5

ASSEMBLAGGIO DELLE PINZE NELLE GHIERE ER

ASSEMBLING OF COLLETS IN ER NUTS



Figura 1

CORRETTO PROCEDIMENTO PER L'ASSEMBLAGGIO DELLA PINZA NELLA GHIERA

- A) Introdurre la pinza nella ghiera inclinandola fino ad accoppiare la scanalatura della pinza con la sede eccentrica della ghiera (figura 1).
- B) Una volta montata la pinza nella ghiera (punto A), avvitare l'assieme sul mandrino.
- C) Dopo aver inserito l'utensile nella pinza, si consiglia l'utilizzo dell'apposita chiave per completare il serraggio.

RIGHT PROCEDURE TO ASSEMBLE THE COLLET IN THE NUT

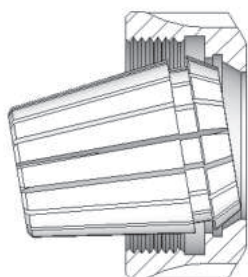
- A) Insert the collet into the nut inclining it until the collet groove matches with nut excentric seat (picture 1).
- B) Once the collet has been mounted in the nut (point A), screw the assembly on the spindle.
- C) After insert the tool into the collet, is suggested to use the suitable wrench to complete the tightening.



Figura 2

ERRATO PROCEDIMENTO PER L'ASSEMBLAGGIO DELLA PINZA NELLA GHIERA

- D) L'inserimento della pinza nella sede mandrino senza averla assemblata nella ghiera (figura 2) compromette irrimediabilmente l'integrità dell'assieme :
 - l'eccentrico situato all'interno della ghiera si rompe a causa della pressione esercitata dalla pinza. Tale rottura non permetterà più l'estrazione della pinza che quindi rimarrà bloccata nella sua sede.
 - durante l'avvitamento della ghiera, i residui dell'eccentrico rotto provocano delle scalfiture sulla parte conica rettificata della pinza pregiudicandone il corretto accoppiamento.

WRONG PROCEDURE TO ASSEMBLE THE COLLET IN THE NUT

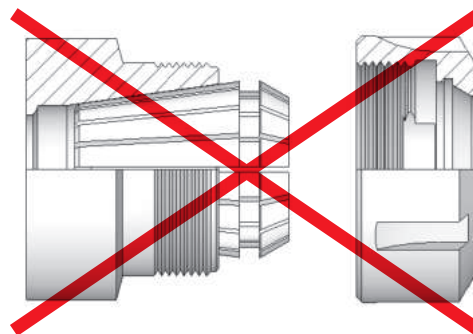
- D) Inserting the collet into the spindle seat without first assembling it with the nut (picture 2) irremediably compromises the whole integrity :
 - excentric in the nut breaks because of the pressure made by the collet. Such a breakage will not permit anymore the extraction of the collet that then will stay locked in its seat.
 - during the nut screwing, broken excentric residuals cause scrapes on conic grinded part of the collet compromising the exact matching.

G 6,3 - 15.000 rpm Balanced



DIN 6499
ISO 15488

GHIERE ER TIPO MINI
ER CLAMPING NUTS MINI TYPE

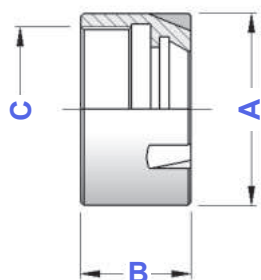

GM



FILETTO DESTRO
RIGHT THREAD



TIPO	Art.	A	B	C		
GM 8	0373	12	11	10 x 0,75	0554	5717
GM 11	0432	16	12	13 x 0,75	5573	5718
GM 16	1229	22	18	19 x 1,00	0364	5719
GM 20	1230	28	19	24 x 1,00	0787	5720
GM 25	1231	35	20	30 x 1,00	0996	5721

FILETTO SINISTRO
LEFT THREAD

TIPO	Art.	A	B	C		
GM 8 L	1188	12	10	10 x 0,75 SX	0554	5717
GM 11 L	1189	16	12	13 x 0,75 SX	5573	5718
GM 16 L	1233	22	18	19 x 1,00 SX	0364	5719
GM 20 L	1234	28	19	24 x 1,00 SX	0787	5720
GM 25 L	1235	35	20	30 x 1,00 SX	0996	5721

FILETTO DESTRO
RETTIFICATE ESTERNAMENTE
GRINDED OUTSIDE - RIGHT THREAD



TIPO	Art.	A	B	C		
GM 8 W	5690	12	10	10 x 0,75	0554	5717
GM 11 W	5691	16	12	13 x 0,75	5573	5718
GM 16 W	5694	22	18	19 x 1,00	0364	5719
GM 20 W	5695	28	19	24 x 1,00	0787	5720
GM 25 W	5696	35	20	30 x 1,00	0996	5721

G 6,3 - 15.000 rpm Balanced



DIN 6499
ISO 15488

GHIERE ER TIPO ESAGONALE
ER CLAMPING NUTS HEXAGONAL TYPE

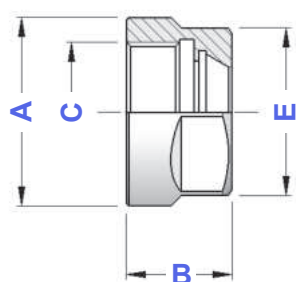
GE



FILETTO DESTRO
RIGHT THREAD

TIPO	Art.	A	E	B	C		
GE 11	1157	19	17	11,3	14 x 0,75	5573	2905
GE 12	0342	19	17	14,0	14 x 0,75	5601	2905
GE 16	1214	28	25	17,5	22 x 1,50	0364	2906
GE 20	1215	34	30	19,0	25 x 1,50	0787	2907

G 6,3 - 15.000 rpm Balanced

DIN 6499
ISO 15488

GHIERE ER TIPO STANDARD
ER CLAMPING NUTS STANDARD TYPE

GS

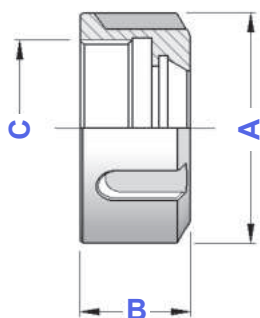

FILETTO DESTRO
RIGHT THREAD

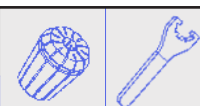

TIPO	Art.	A	B	C		
GS 16	4993	32	17,5	22 x 1,5	0364	3698
GS 20	4994	35	19,0	25 x 1,5	0787	3699
GS 25	4995	42	20,0	32 x 1,5	0996	3669
GS 32	4996	50	22,5	40 x 1,5	0988	3670
GS 40	4997	63	25,5	50 x 1,5	0821	3671
GS 50	4998	78	35,5	64 x 2,0	4055	3668

FILETTO SINISTRO
LEFT THREAD

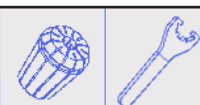

TIPO	Art.	A	B	C		
GS 16 L	3071	32	17,5	22 x 1,5 SX	0364	3698
GS 20 L	3072	35	19,0	25 x 1,5 SX	0787	3699
GS 25 L	3073	42	20,0	32 x 1,5 SX	0996	3669
GS 32 L	3074	50	22,5	40 x 1,5 SX	0988	3670
GS 40 L	3075	63	25,5	50 x 1,5 SX	0821	3671

DIN 6499
ISO 15488

GHIERE ER TIPO STANDARD
VERSIONE CON CIRCOLAZIONE DI SFERE
ER CLAMPING NUTS STANDARD TYPE - BALL BEARING EXECUTION

GS-B

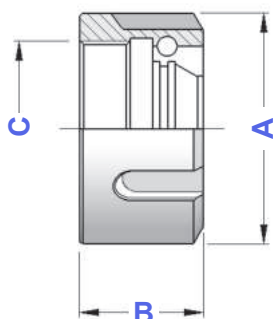

FILETTO DESTRO
RIGHT THREAD

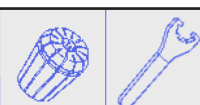

TIPO	Art.	A	B	C		
GS 16 B	2713	32	20,0	22 x 1,5	0364	3698
GS 20 B	2714	35	22,0	25 x 1,5	0787	3699
GS 25 B	2715	42	22,5	32 x 1,5	0996	3669
GS 32 B	2716	50	25,0	40 x 1,5	0988	3670
GS 40 B	2717	63	28,0	50 x 1,5	0821	3671
GS 50 B	2913	78	40,0	64 x 2,0	4055	3668
GS 60 B	5714	83	36,0	70 x 1,5	4056	—

CARATTERISTICHE E VANTAGGI

- Aumenta la forza di serraggio della pinza.
- Evita la torsione della pinza riducendone l'attrito con la sua sede e conseguentemente ne preserva la precisione.
- E' intercambiabile con le normali ghiera standard ed esagonali.

CHARACTERISTICS AND ADVANTAGES

- Collet clamping force is increased.
- Avoids collet torsion reducing friction with its seat and consequently preserves its accuracy.
- Interchangeable with standard and hexagonal nuts.

DIN 6499
ISO 15488

GHIERE ER CON FILETTO ESTERNO - TIPO "GA"
ER CLAMPING NUTS WITH OUTSIDE THREAD - "GA" TYPE

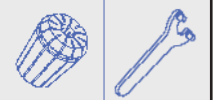

TIPO	Art.	B	M	D1		
GA 11	2867	6,0	18 x 1,0	9,0	5573	3169
GA 16	2868	8,0	24 x 1,0	12,8	0364	3170
GA 20	2869	11,0	28 x 1,5	16,0	0787	3171
GA 25	2870	12,5	32 x 1,5	18,0	0996	3172
GA 32	2871	14,0	40 x 1,5	25,5	0988	3173

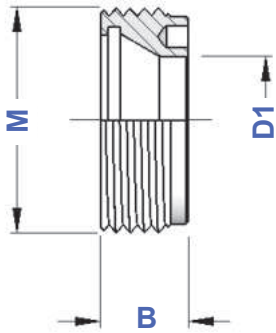

CHIAVI PER GHIERE TIPO "GA"
WRENCHES FOR "GA" TYPE CLAMPING NUTS



TIPO	Art.	
CH ER 11 GA	3169	2867
CH ER 16 GA	3170	2868
CH ER 20 GA	3171	2869
CH ER 25 GA	3172	2870
CH ER 32 GA	3173	2871

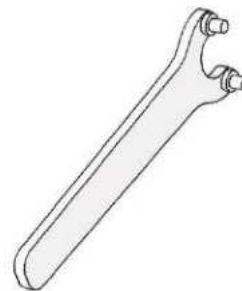

DIN 6499
ISO 15488

GHIERE ER CON FILETTO ESTERNO - TIPO "GA-E"
CON PRESA DI CHIAVE ESAGONALE
ER CLAMPING NUTS "GA-E" TYPE WITH OUTSIDE THREAD - HEXAGONAL HOLD



TIPO	Art.	E	B	M	D1		
GA 11 E	2601	13	10,0	18 x 1,0	9,0	5573	5491
GA 16 E	2606	19	11,0	24 x 1,0	12,8	0364	5492
GA 20 E	2610	22	14,0	28 x 1,5	16,0	0787	5493
GA 25 E	2611	27	14,0	32 x 1,5	20,5	0996	5494
GA 32 E	2612	32	17,5	40 x 1,5	25,5	0988	5495
GA 40 E	2613	42	17,1	50 x 1,5	34,0	0821	5496

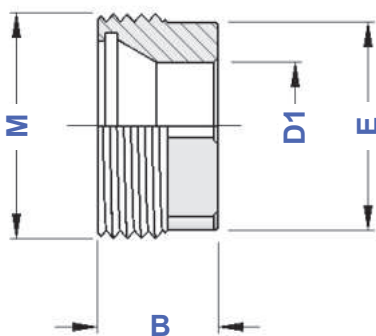

CHIAVI PER GHIERE TIPO "GA-E"
WRENCHES FOR "GA-E" TYPE CLAMPING NUTS



TIPO	Art.	
CH ER 11 GA-E	5491	2601
CH ER 16 GA-E	5492	2606
CH ER 20 GA-E	5493	2610
CH ER 25 GA-E	5494	2611
CH ER 32 GA-E	5495	2612
CH ER 40 GA-E	5496	2613



DIN 6499
ISO 15488
MINI

CHIAVI ER PER GHIERE MINI
ER WRENCHES FOR MINI CLAMPING NUTS

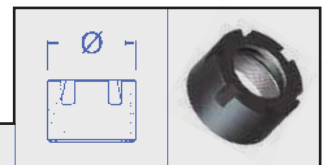

TIPO	Art.		
CH 8 Mini	5717	12	0373
CH 11 Mini	5718	16	0432
CH 16 Mini	5719	22	1229
CH 20 Mini	5720	28	1230
CH 25 Mini	5721	35	1231

DIN 6499
ISO 15488
CE

CHIAVI ER PER GHIERE ESAGONALI
ER WRENCHES FOR EXAGONAL CLAMPING NUTS



TIPO	Art.		
CH 11 CE	2905	17	1157
CH 12 CE	2905	17	0342
CH 16 CE	2906	25	1214
CH 20 CE	2907	30	1215

DIN 6499
ISO 15488
ST

CHIAVI ER PER GHIERE STANDARD
ER WRENCHES FOR STANDARD CLAMPING NUTS

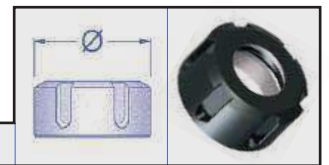

TIPO	Art.		
CH 16 ST	3698	32	4993
CH 20 ST	3699	35	4994
CH 25 ST	3669	42	4995
CH 32 ST	3670	50	4996
CH 40 ST	3671	63	4997
CH 50 ST	3668	78	4998

DIN 6499
ISO 15488
GT

CHIAVI ER PER GHIERE CON PRESA LATERALE
ER WRENCHES FOR SIDE GRIP CLAMPING NUTS

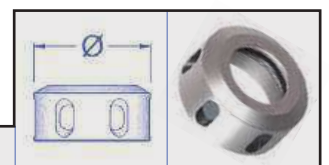

TIPO	Art.		
CH 11 GT	2880	20	5090
CH 16 GT	2881	32	5091
CH 20 GT	2882	35	5092
CH 25 GT	2883	42	5093
CH 32 GT	2908	50	5094
CH 40 GT	2909	63	5095

DIN 6499
ISO 15488
CD MINI

**CHIAVI ER PER GHIERE MINI
DINAMOMETRICHE**
ER TORQUE WRENCHES FOR MINI CLAMPING NUTS



TIPO	Art.	MOMENTO TORCENTE TORQUE			
CD 8 Mini	9786	8 Nm		12	0373
CD 11 Mini	9787	18 Nm		16	0432
CD 16 Mini	9788	28 Nm		22	1229
CD 20 Mini	9789	35 Nm		28	1230
CD 25 Mini	9790	40 Nm		35	1231

DIN 6499
ISO 15488
CD CE

**CHIAVI ER PER GHIERE ESAGONALI
DINAMOMETRICHE**
ER TORQUE WRENCHES FOR HEXAGONAL CLAMPING NUTS

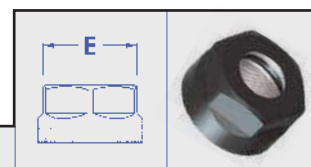

TIPO	Art.	MOMENTO TORCENTE TORQUE			
CD 11 CE	9791	20 Nm		17	1157
CD 12 CE	9791	20 Nm		17	0342
CD 16 CE	9792	30 Nm	50 Nm	25	1214
CD 20 CE	9793	40 Nm	70 Nm	30	1215

DIN 6499
ISO 15488
CD ST

**CHIAVI ER PER GHIERE STANDARD
DINAMOMETRICHE**
ER TORQUE WRENCHES FOR STANDARD CLAMPING NUTS

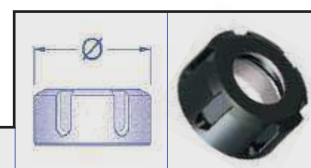

TIPO	Art.	MOMENTO TORCENTE TORQUE			
CD 16 ST	9794	30 Nm	50 Nm	32	4993
CD 20 ST	9795	40 Nm	70 Nm	35	4994
CD 25 ST	9796	55 Nm	90 Nm	42	4995
CD 32 ST	9797	70 Nm	130 Nm	50	4996
CD 40 ST	9798	120 Nm	200 Nm	63	4997

Con pinza scaricata internamente,
selezionare il Momento Torcente **MINIMO**

With discharged inside collet,
select the **MINIMUM** Torque

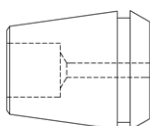

Con pinza non scaricata internamente,
selezionare il Momento Torcente **MASSIMO**

With collet not discharged inside,
select the **MAXIMUM** Torque

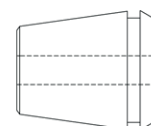

INDICE DELL' ATTACCO CILINDRICO

INDEX OF STRAIGHT SHANK DIN 1835

PORTAPINZA ER ghiera MINI

ER MINI NUT
COLLET CHUCKS
pag. 34 - 36



PORTAPINZA ER DOPPIO ghiera MINI

DOUBLE ER MINI NUT
COLLET CHUCKS
pag. 36



PORTAPINZA ER ghiera ESAGONALE

ER HEXAGONAL NUT
COLLET CHUCKS
pag. 37



PORTAPINZA ER ghiera STANDARD

ER STANDARD NUT
COLLET CHUCKS
pag. 38 - 40



PORTAPINZA ER con FORI di LUBRIFICAZIONE

ER COLLET CHUCKS
with COOLING HOLES
pag. 40



PORTAPINZA ER con ghiera INTERNA

ER COLLET CHUCKS
with INNER NUT
pag. 41



attacchi per MANDRINI AUTOSERRANTI

SHANKS for DIN 238
DRILL CHUCKS
pag. 41



AUTOSERRANTI INTEGRALI ROTAZIONE DESTRA

RIGH SPIN
MONOLITHIC DRILL CHUCKS
pag. 42



AUTOSERRANTI INTEGRALI ROTAZIONE DESTRA e SINISTRA

RIGH and LEFT SPIN
MONOLITHIC DRILL CHUCKS
pag. 42



RIDUZIONI WELDON

WELDON REDUCTIONS
pag. 43



MASCHIATORI DOPPIA COMPENSAZIONE

DOUBLE COMPENSATION
TAPPING CHUCKS
pag. 44-45



MASCHIATORI SENZA COMPENSAZIONE

TAPPING CHUCKS
WITHOUT COMPENSATION
pag. 45



PORTA FRESE con ATTACCO FILETTATO

THREADED SHANK MILLING
CUTTERS HOLDERS
pag. 46



adattatori da STELO CILINDRICO a POLIGONALE

CYLINDRICAL SHANK ADAPTERS
to POLYGONAL DIN ISO 26623-1
pag. 209



BUSSOLE di RIDUZIONE

REDUCTION LEEVES
pag. 288



STRINGIBARRA

BAR PULLERS
pag. 331



➔ segue
continue

FERMOBARRA ROTANTI

ROTARY BAR STOP

pag. 340



PORTA MASCHI ad ESTRAZIONE

DRAW-OUT TAPPING CHUCKS

pag. 342



PORTA MASCHI DOPPIA COMPENSAZIONE con ER

DOUBLE COMPENSATION TAPPING CHUCKS with ER COLLET

pag. 343



PORTA FILIERE FISSI

FIXED TREADING DIE HOLDERS

pag. 345



PORTAUTENSILI COMBINATI SEMPLICI TORNIRE-FORARE

TURN AND DRILL SIMPLE TOOLHOLDERS

pag. 354



PORTAUTENSILI COMBINATI DOPPI TORNIRE-FORARE

TURN AND DRILL DOUBLE TOOLHOLDERS

pag. 355



PORTAUTENSILI REGISTRABILI PER INTERNI

ADJUSTABLE TOOLHOLDERS FOR INNER WORKING

pag. 356



PORTAUTENSILI PER RECESSI INTERNI

TOOLHOLDERS FOR INNERS

pag. 357



PORTA ALESATORI

FLOATING REAMER HOLDERS

pag. 341



PORTA MASCHI ad ESTRAZIONE con PINZA ER

DRAW-OUT TAPPING CHUCKS with ER COLLET

pag. 342



PORTA FILIERE ad ESTRAZIONE

DRAW-OUT TREADING DIE HOLDERS

pag. 344



BROCCIATORI POLIGONATORI

BROACHING TOOL HOLDERS

pag. 347



PORTAUTENSILI COMBINATI SEMPLICI con PINZA ER

TURN AND DRILL SIMPLE TOOLHOLDERS with ER COLLET

pag. 354



PORTAUTENSILI COMBINATI DOPPI con PINZA ER

TURN AND DRILL DOUBLE TOOLHOLDERS with ER COLLET

pag. 355



PORTAUTENSILI REGISTRABILI PER INTERNI con PINZA ER

ADJUSTABLE TOOLHOLDERS FOR INNER WORKING with ER COLLET

pag. 356



PORTAUTENSILI PER RECESSI INTERNI con PINZA ER

TOOLHOLDERS FOR INNERS with ER COLLET

pag. 357



DIN 1835 A

PORTAPINZA ER CON ATTACCO CILINDRICO - GHIERA MINI

STRAIGHT SHANK ER COLLET CHUCKS with MINI NUT



senza Piano
without flat



con Piano
with flat



senza Piano
without flat

con Piano
with flat

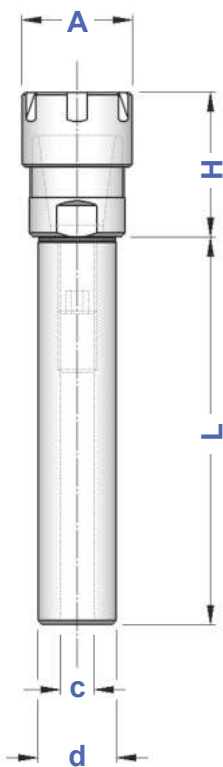

p.30



p.27



p.10



TIPO	Art.	Art.	H	A	C	RANGE			
d 5 - ER 8GM /L 45	3207	—	24	12	—	ER 8 1÷5	0373	5717	0554
d 6 - ER 8GM /L 45	0394	—	24	12	—	ER 8 1÷5	0373	5717	0554
d 6 - ER11GM /L 45	0157	—	25	16	—	ER11 1÷8	0432	5718	5573
d 7 - ER11GM /L 45	0187	—	25	16	—	ER11 1÷8	0432	5718	5573
d 8 - ER 8GM /L 55	0395	—							
d 8 - ER 8GM /L 80	0155	—	24	12	—	ER 8 1÷5	0373	5717	0554
d 8 - ER 8GM /L 100	2000	—							
d 8 - ER 8GM /L 130	2001	—							
d 8 - ER11GM /L 55	2889	—	25	16	—	ER11 1÷8	0432	5718	5573
d 8 - ER11GM /L 100	2894	—							
d 8 - ER16GM /L 55	2026	—	37	22	—	ER16 1÷12	1229	5719	0364
d 8 - ER16GM /L 100	2027	—							
d10 - ER 8GM /L 55	2937	—							
d10 - ER 8GM /L 80	5138	—	24	12	5	ER 8 1÷5	0373	5717	0554
d10 - ER 8GM /L 100	2938	—							
d10 - ER 8GM /L 130	5139	—							
d10 - ER11GM /L 55	2890	—							
d10 - ER11GM /L 80	5140	—	25	16	5	ER11 1÷8	0432	5718	5573
d10 - ER11GM /L 100	2896	—							
d10 - ER11GM /L 130	5141	—							
d10 - ER16GM /L 60	2891	—							
d10 - ER16GM /L 80	5142	—	37	22	5	ER16 1÷12	1229	5719	0364
d10 - ER16GM /L 100	2956	—							
d12 - ER 8GM /L 55	2002	—							
d12 - ER 8GM /L 70	5143	—	15	12	5	ER 8 1÷5	0373	5717	0554
d12 - ER 8GM /L 100	2962	—							
d12 - ER 8GM /L 140	2991	—							
d12 - ER11GM /L 55	2892	—							
d12 - ER11GM /L 70	3208	—	25	16	7	ER11 1÷8	0432	5718	5573
d12 - ER11GM /L 100	3003	—							
d12 - ER11GM /L 140	0217	—							
d12 - ER16GM /L 55	2893	—							
d12 - ER16GM /L 80	3209	—	37	22	7	ER16 1÷12	1229	5719	0364
d12 - ER16GM /L 120	3214	—							
d15 - ER20GM /L 100	3210	—	41	28	9	ER20 1÷15	1230	5720	0787
d16 - ER11GM /L 40	0214 SP	0214 P							
d16 - ER11GM /L 60	0292 SP	0292 P							
d16 - ER11GM /L 80	0441 SP	0441 P							
d16 - ER11GM /L 100	2963 SP	2963 P	22	16	7	ER11 1÷8	0432	5718	5573
d16 - ER11GM /L 130	3903 SP	3903 P							
d16 - ER11GM /L 160	3904 SP	3904 P							
d16 - ER11GM /L 200	3913 SP	3913 P							
d16 - ER16GM /L 35	2591 SP	2591 P							
d16 - ER16GM /L 60	3211 SP	3211 P							
d16 - ER16GM /L 80	3212 SP	3212 P							
d16 - ER16GM /L 100	3226 SP	3226 P	37	22	7	ER16 1÷12	1229	5719	0364
d16 - ER16GM /L 130	3393 SP	3393 P							
d16 - ER16GM /L 160	3490 SP	3490 P							
d16 - ER16GM /L 200	2005 SP	2005 P							
d16 - ER20GM /L 55	2895 SP	2895 P							
d16 - ER20GM /L 100	3213 SP	3213 P							
d16 - ER20GM /L 130	2982 SP	2982 P	40	28	9	ER20 1÷15	1230	5720	0787
d16 - ER20GM /L 160	2983 SP	2983 P							

segue
continue

➔ segue
continue

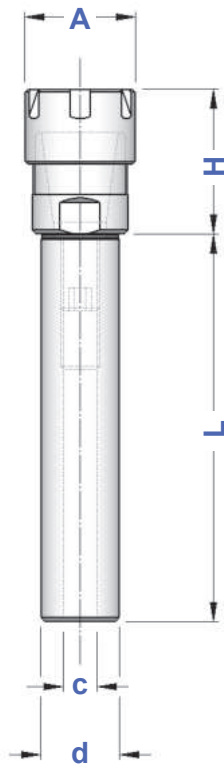
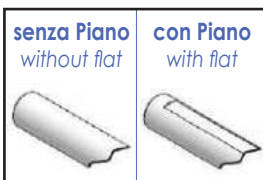

TIPO	Art.	Art.	H	A	C	RANGE			
d 19,05 - ER11GM/L 50 d 19,05 - ER11GM/L 100	— —	0189 3013	18	16	7	ER11 1÷8	0432	5718	5573
d 19,05 - ER16GM/L 60 d 19,05 - ER16GM/L 100	— —	0215 3394	30	22	11	ER16 1÷12	1229	5719	0364
d 19,05 - ER20GM/L 50 d 19,05 - ER20GM/L 100	— —	0226 3397	37	28	11	ER20 1÷15	1230	5720	0787
d 19,05 - ER25GM/L 50	—	2897	46	35	11	ER25 1÷20	1231	5721	0996
d 20 - ER11 GM /L 50 d 20 - ER11 GM /L 100 d 20 - ER11 GM /L 130 d 20 - ER11 GM /L 160 d 20 - ER11 GM /L 200	0216 SP 1222 SP 2042 SP 2043 SP 5144 SP	0216 P 1222 P 2042 P 2043 P 5144 P	22	16	7	ER11 1÷8	0432	5718	5573
d 20 - ER16 GM /L 60 d 20 - ER16 GM /L 100 d 20 - ER16 GM /L 130 d 20 - ER16 GM /L 160 d 20 - ER16 GM /L 200 d 20 - ER16 GM /L 250	3905 SP 3520 SP 3909 SP 3521 SP 3522 SP 3528 SP	3905 P 3520 P 3909 P 3521 P 3522 P 3528 P	30	22	11	ER16 1÷12	1229	5719	0364
d 20 - ER20 GM /L 46 d 20 - ER20 GM /L 60 d 20 - ER20 GM /L 100 d 20 - ER20 GM /L 130 d 20 - ER20 GM /L 160 d 20 - ER20 GM /L 200 d 20 - ER20 GM /L 250	3215 SP 0220 SP 3216 SP 3217 SP 0225 SP 3227 SP 3285 SP	3215 P 0220 P 3216 P 3217 P 0225 P 3227 P 3285 P	37	28	11	ER20 1÷15	1230	5720	0787
d 20 - ER25 GM /L 46 d 20 - ER25 GM /L 60 d 20 - ER25 GM /L 100 d 20 - ER25 GM /L 130 d 20 - ER25 GM /L 160	2899 SP 3906 SP 3218 SP 0228 SP 3319 SP	2899 P 3906 P 3218 P 0228 P 3319 P	46	35	11	ER25 1÷20	1231	5721	0996
d 22 - ER16 GM /L 80	—	0408	27	22	11	ER16 1÷12	1229	5719	0364
d 22 - ER20 GM /L 80	—	0412	30	28	11	ER20 1÷15	1230	5720	0787
d 25 - ER11 GM /L 100 d 25 - ER11 GM /L 130 d 25 - ER11 GM /L 160	0451 SP 5145 SP 5146 SP	0451 P 5145 P 5146 P	18	16	7	ER11 1÷8	0432	5718	5573
d 25 - ER16 GM /L 60 d 25 - ER16 GM /L 100 d 25 - ER16 GM /L 130 d 25 - ER16 GM /L 160 d 25 - ER16 GM /L 200	0218 SP 0219 SP 0231 SP 3029 SP 3063 SP	0218 P 0219 P 0231 P 3029 P 3063 P	27	22	11	ER16 1÷12	1229	5719	0364
d 25 - ER20 GM /L 60 d 25 - ER20 GM /L 100 d 25 - ER20 GM /L 130 d 25 - ER20 GM /L 160 d 25 - ER20 GM /L 200	3907 SP 0221 SP 0222 SP 3219 SP 4004 SP	3907 P 0221 P 0222 P 3219 P 4004 P	28	28	13	ER20 1÷15	1230	5720	0787
d 25 - ER25 GM /L 50 d 25 - ER25 GM /L 70 d 25 - ER25 GM /L 100 d 25 - ER25 GM /L 130 d 25 - ER25 GM /L 160 d 25 - ER25 GM /L 200	0227 SP 3908 SP 0426 SP 0446 SP 0449 SP 0462 SP	0227 P 3908 P 0426 P 0446 P 0449 P 0462 P	32	35	13	ER25 1÷20	1231	5721	0996
d 25,4 - ER16 GM /L 60 d 25,4 - ER16 GM /L 100	— —	3030 3031	27	22	11	ER16 1÷12	1229	5719	0364
d 25,4 - ER20 GM /L 70 d 25,4 - ER20 GM /L 100	— —	3912 0421	28	28	13	ER20 1÷15	1230	5720	0787
d 25,4 - ER25 GM /L 70 d 25,4 - ER25 GM /L 100	— —	3914 0433	32	35	13	ER25 1÷20	1231	5721	0996
d 32 - ER16 GM /L 90	—	3395	30	22	11	ER16 1÷12	1229	5719	0364
d 32 - ER20 GM /L 90	—	3396	28	28	13	ER20 1÷15	1230	5720	0787



**DIN
1835 B+E**

PORTAPINZA ER CON ATTACCO CILINDRICO WE - GHIERA MINI
WE SHANK ER COLLET CHUCKS with MINI NUT

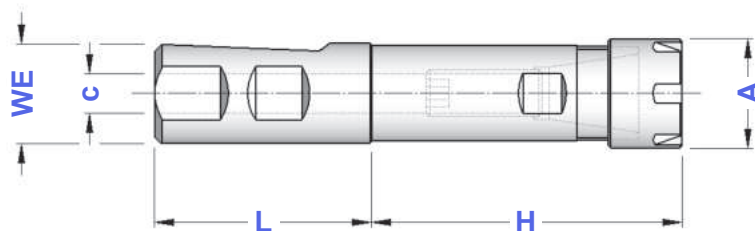

TIPO	Art.	H	L	A	C	RANGE			
WE 16 - ER 11 GM	3189	80	48	16	7	ER 11 1÷8	0432	5718	5573
WE 16 - ER 16 GM	3190	80	48	22	9	ER 16 1÷12	1229	5719	0364
WE 20 - ER 16 GM	3253	80	50	22	11	ER 16 1÷12	1229	5719	0364
WE 25 - ER 16 GM	3255	80	56	22	11	ER 16 1÷12	1229	5719	0364
WE 25 - ER 20 GM	3256	80	56	28	13	ER 20 1÷15	1230	5720	0787

**DIN
1835 A**

PORTAPINZA ER DOPPI ATTACCO CILINDRICO - GHIERA MINI
STRAIGHT SHANK ER DOUBLE COLLET CHUCKS with MINI NUT

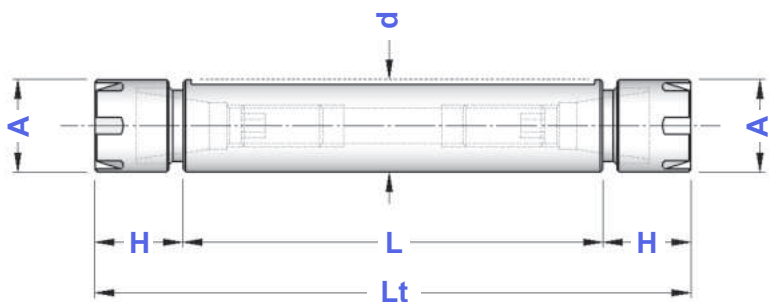

TIPO	Art.	H	Lt	A	RANGE			
d 20 DP - ER 11 GM / L 42	8779	14,0	70	16	ER 11 1÷8	0432	5718	5573
d 20 DP - ER 11 GM / L 52	8780	14,0	80					
d 20 DP - ER 11 GM / L 62	8781	14,0	90					
d 20 DP - ER 16 GM / L 37	8782	21,5	80	22	ER 16 1÷12	1229	5719	0364
d 20 DP - ER 16 GM / L 57	8783	21,5	100					
d 20 DP - ER 16 GM / L 67	8784	21,5	110					
d 20 DP - ER 16 GM / L 122	8988	21,5	165					
d 22 DP - ER 16 GM / L 47	8785	21,5	90	22	ER 16 1÷12	1229	5719	0364
d 22 DP - ER 16 GM / L 67	8786	21,5	110					
d 22 DP - ER 16 GM / L 102	8787	21,5	145					
d 25 DP - ER 16 GM / L 27	8788	21,5	70	22	ER 16 1÷12	1229	5719	0364
d 25 DP - ER 16 GM / L 47	8789	21,5	90					
d 25 DP - ER 16 GM / L 67	8790	21,5	110					
d 25 DP - ER 20 GM / L 82	8791	24,0	130	28	ER 20 1÷15	1230	5720	0787
d 32 DP - ER 20 GM / L 57	8792	24,0	105	28	ER 20 1÷15	1230	5720	0787
d 32 DP - ER 20 GM / L 82	8793	24,0	130					

**DIN
1835 A**

PORTAPINZA ER CON ATTACCO CILINDRICO - GHIERA ESAGONALE

STRAIGHT SHANK ER COLLET CHUCKS with HEXAGONAL NUT





senza Piano
without flat

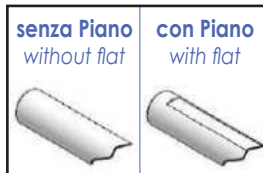
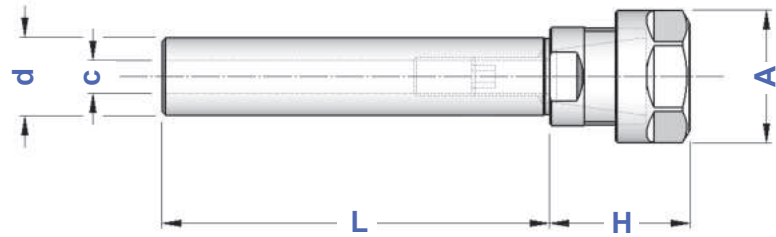

con Piano
with flat



TIPO	Art.	Art.	H	A	C	RANGE			
d 14 - ER 16 GE / L 60	5244	—	36	28	7	ER 16 1÷12	1214	2906	0364
d 16 - ER 16 GE / L 60	5245 SP	5245 P	36	28	7	ER 16 1÷12	1214	2906	0364
d 16 - ER 16 GE / L 80	5246 SP	5246 P							
d 16 - ER 16 GE / L 100	5247 SP	5247 P							
d 16 - ER 16 GE / L 130	5248 SP	5248 P							
d 16 - ER 16 GE / L 160	5249 SP	5249 P							
d 16 - ER 20 GE / L 60	5251 SP	5251 P	40	34	9	ER 20 1÷15	1215	2907	0787
d 19,05 - ER 16 GE / L 50	—	5252	32	28	11	ER 16 1÷12	1214	2906	0364
d 19,05 - ER 16 GE / L 100	—	5253							
d 19,05 - ER 20 GE / L 50	—	5254	36	34	11	ER 20 1÷15	1215	2907	0787
d 20 - ER 16 GE / L 50	5256 SP	5256 P	31	28	11	ER 16 1÷12	1214	2906	0364
d 20 - ER 16 GE / L 100	5257 SP	5257 P							
d 20 - ER 16 GE / L 130	5258 SP	5258 P							
d 20 - ER 16 GE / L 160	5259 SP	5259 P							
d 20 - ER 16 GE / L 200	5260 SP	5260 P							
d 20 - ER 20 GE / L 46	5261 SP	5261 P	36	34	11	ER 20 1÷15	1215	2907	0787
d 20 - ER 20 GE / L 60	5262 SP	5262 P							
d 20 - ER 20 GE / L 100	5263 SP	5263 P							
d 20 - ER 20 GE / L 130	5264 SP	5264 P							
d 20 - ER 20 GE / L 160	5265 SP	5265 P							
d 20 - ER 20 GE / L 200	5266 SP	5266 P							
d 22 - ER 16 GE / L 80	—	5267							
d 22 - ER 20 GE / L 80	—	5268	36	34	11	ER 20 1÷15	1215	2907	0787
d 25 - ER 16 GE / L 60	5269 SP	5269 P	27	28	11	ER 16 1÷12	1214	2906	0364
d 25 - ER 16 GE / L 100	5270 SP	5270 P							
d 25 - ER 16 GE / L 130	5271 SP	5271 P							
d 25 - ER 16 GE / L 160	—	5272 P							
d 25 - ER 20 GE / L 60	5274 SP	5274 P	28	34	13	ER 20 1÷15	1215	2907	0787
d 25 - ER 20 GE / L 100	5275 SP	5275 P							
d 25 - ER 20 GE / L 130	5276 SP	5276 P							
d 25 - ER 20 GE / L 160	5277 SP	5277 P							
d 25,4 - ER 16 GE / L 60	—	5278	27	28	11	ER 16 1÷12	1214	2906	0364
d 25,4 - ER 16 GE / L 100	—	5279							
d 25,4 - ER 20 GE / L 60	—	5280	28	34	13	ER 20 1÷15	1215	2907	0787
d 25,4 - ER 20 GE / L 100	—	5281							
d 32 - ER 16 GE / L 100	—	5284	27	28	11	ER 16 1÷12	1214	2906	0364
d 32 - ER 16 GE / L 150	—	5285							
d 32 - ER 20 GE / L 100	—	5286	28	34	13	ER 20 1÷15	1215	2907	0787
d 32 - ER 20 GE / L 150	—	5287							



p.10



p.27



p.30

**DIN
1835 A**

PORTAPINZA ER CON ATTACCO CILINDRICO - GHIERA STANDARD

STRAIGHT SHANK ER COLLET CHUCKS with STANDARD NUT



senza Piano
without flat



con Piano
with flat

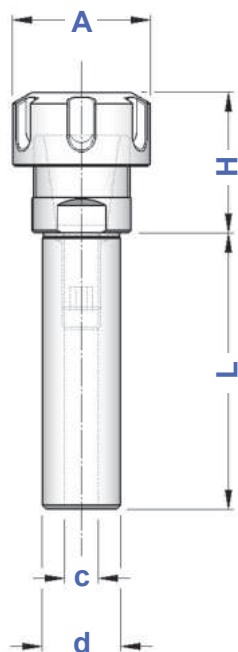

p.30



p.28



p.10

TIPO	Art.	Art.	H	A	C	RANGE			
d 14 - ER 16 / L 60	3915	—	36	32	7	ER16 1÷12	4993	3698	0364
d 16 - ER 16 / L 60	3916 SP	3916 P	36	32	7	ER16 1÷12	4993	3698	0364
d 16 - ER 16 / L 80	5009 SP	5009 P							
d 16 - ER 16 / L 100	3185 SP	3185 P							
d 16 - ER 16 / L 130	5087 SP	5087 P							
d 16 - ER 16 / L 160	3206 SP	3206 P							
d 16 - ER 20 / L 60	3529 SP	3529 P	40	35	9	ER20 1÷15	4994	3699	0787
d 16 - ER 25 / L 35	0573 SP	0573 P	46	42	9	ER25 1÷20	4995	3669	0996
d 16 - ER 25 / L 70	0574 SP	0574 P							
d 19,05 - ER16/L 50	—	3929	32	32	11	ER16 1÷12	4993	3698	0364
d 19,05 - ER16/L100	—	0229							
d 19,05 - ER20/L 50	—	3930	36	35	11	ER20 1÷15	4994	3699	0787
d 19,05 - ER25/L 50	—	2379	46	42	11	ER25 1÷20	4995	3669	0996
d 19,05 - ER32/L 50	—	5096	54	50	13	ER32 2÷25	4996	3670	0988
d 20 - ER 16 / L 50	3917 SP	3917 P	31	32	11	ER16 1÷12	4993	3698	0364
d 20 - ER 16 / L 100	3918 SP	3918 P							
d 20 - ER 16 / L 130	5098 SP	5098 P							
d 20 - ER 16 / L 160	3228 SP	3228 P							
d 20 - ER 16 / L 200	5099 SP	5099 P							
d 20 - ER 20 / L 46	3919 SP	3919 P	36	35	11	ER20 1÷15	4994	3699	0787
d 20 - ER 20 / L 60	3920 SP	3920 P							
d 20 - ER 20 / L 100	0381 SP	0381 P							
d 20 - ER 20 / L 130	5147 SP	5147 P							
d 20 - ER 20 / L 160	5148 SP	5148 P							
d 20 - ER 20 / L 200	5149 SP	5149 P							
d 20 - ER 25 / L 50	2600 SP	2600 P	46	42	11	ER25 1÷20	4995	3669	0996
d 20 - ER 25 / L 100	3921 SP	3921 P							
d 20 - ER 25 / L 160	3911 SP	3911 P							
d 20 - ER 32 / L 50	3203 SP	3203 P	54	50	13	ER32 2÷25	4996	3670	0988
d 20 - ER 32 / L 100	3922 SP	3922 P							
d 20 - ER 32 / L 130	3931 SP	3931 P							
d 20 - ER 32 / L 160	3932 SP	3932 P							
d 22 - ER 16 / L 80	—	0434	26	32	11	ER16 1÷12	4993	3698	0364
d 22 - ER 20 / L 80	—	0436	36	35	11	ER20 1÷15	4994	3699	0787
d 22 - ER 25 / L 50	—	3177	42	42	13	ER25 1÷20	4995	3669	0996
d 22 - ER 32 / L 50	—	3178	53	50	13	ER32 2÷25	4996	3670	0988
d 25 - ER 16 / L 60	5163 SP	5163 P	27	32	11	ER16 1÷12	4993	3698	0364
d 25 - ER 16 / L 100	5164 SP	5164 P							
d 25 - ER 16 / L 130	5165 SP	5165 P							
d 25 - ER 16 / L 160	—	5166 P							
d 25 - ER 20 / L 60	0230 SP	0230 P	28	35	13	ER20 1÷15	4994	3699	0787
d 25 - ER 20 / L 100	0383 SP	0383 P							
d 25 - ER 20 / L 130	5168 SP	5168 P							
d 25 - ER 20 / L 160	5169 SP	5169 P							
d 25 - ER 25 / L 50	3923 SP	3923 P	32	42	13	ER25 1÷20	4995	3669	0996
d 25 - ER 25 / L 70	5183 SP	5183 P							
d 25 - ER 25 / L 100	0391 SP	0391 P							
d 25 - ER 25 / L 130	0392 SP	0392 P							
d 25 - ER 25 / L 160	0393 SP	0393 P							

segue
continue 

➔ segue
continue



senza Piano
without flat



con Piano
with flat

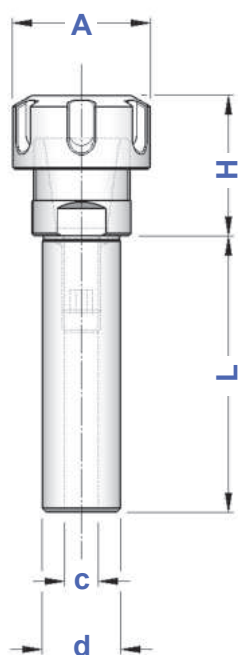
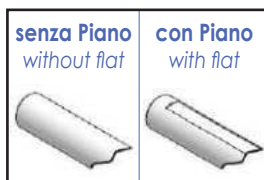

p.30



p.28



p.10



TIPO	senza Piano without flat		con Piano with flat		H	A	C	RANGE			
	Art.	Art.	Art.	Art.							
d25 - ER 32 / L 50 d25 - ER 32 / L 70 d25 - ER 32 / L 100 d25 - ER 32 / L 130 d25 - ER 32 / L 160	1216 SP 1221 SP 3924 SP 3927 SP 3928 SP	1216 P 1221 P 3924 P 3927 P 3928 P			54	50	13	ER32 2÷25	4996	3670	0988
d25 - ER 40 / L 50 d25 - ER 40 / L 100	2901 SP 3266 SP	2901 P 3266 P			60	63	13	ER40 3÷32	4997	3671	0821
d 25,4 - ER 16 / L 60 d 25,4 - ER 16 / L 100	— —	5184 5185			27	32	11	ER16 1÷12	4993	3698	0364
d 25,4 - ER 20 / L 60 d 25,4 - ER 20 / L 100	— —	0296 0386			28	35	13	ER20 1÷15	4994	3699	0787
d 25,4 - ER 25 / L 50 d 25,4 - ER 25 / L 70 d 25,4 - ER 25 / L 100	— — —	3933 5186 3934			32	42	13	ER25 1÷20	4995	3669	0996
d 25,4 - ER 32 / L 50 d 25,4 - ER 32 / L 70 d 25,4 - ER 32 / L 100	— — —	1217 5187 3935			54	50	13	ER32 2÷25	4996	3670	0988
d 25,4 - ER 40 / L 50	—	1917			60	63	13	ER40 3÷32	4997	3671	0821
d30 - ER 25 / L 50	—	3925			45	42	19	ER25 1÷20	4995	3669	0996
d30 - ER 32 / L 50	—	2593			53	50	23	ER32 2÷25	4996	3670	0988
d 31,75 - ER32/L 50	—	1218			44	50	23	ER32 2÷25	4996	3670	0988
d 31,75 - ER40/L 50	—	3938			60	63	23	ER40 3÷32	4997	3671	0821
d32 - ER 16 / L 100 d32 - ER 16 / L 150	— —	5188 5189			27	32	11	ER16 1÷12	4993	3698	0364
d32 - ER 20 / L 100 d32 - ER 20 / L 150	— —	5190 5191			28	35	13	ER20 1÷15	4994	3699	0787
d32 - ER 25 / L 70 d32 - ER 25 / L 100 d32 - ER 25 / L 120	— — —	0307 5192 0309			28	42	19	ER25 1÷20	4995	3669	0996
d32 - ER 32 / L 50 d32 - ER 32 / L 70 d32 - ER 32 / L 100 d32 - ER 32 / L 120 d32 - ER 32 / L 150	— — — — —	1424 3181 0402 0450 3398			38	50	23	ER32 2÷25	4996	3670	0988
d32 - ER 40 / L 70 d32 - ER 40 / L 100 d32 - ER 40 / L 130	— — —	0405 5194 5195			60	63	23	ER40 3÷32	4997	3671	0821
d35 - ER 32 / L 80	—	5196			38	50	23	ER32 2÷25	4996	3670	0988
d40 - ER 25 / L 70 d40 - ER 25 / L 120	— —	3405 3406			42	42	19	ER25 1÷20	4995	3669	0996
d40 - ER 32 / L 70 d40 - ER 32 / L 100 d40 - ER 32 / L 130 d40 - ER 32 / L 160	— — — —	3204 3356 3399 3357			30	50	23	ER32 2÷25	4996	3670	0988
d40 - ER 40 / L 50 d40 - ER 40 / L 80 d40 - ER 40 / L 130	— — —	3205 0406 3942			60	63	28	ER40 3÷32	4997	3671	0821
d 44,45 - ER32/L 160	—	3424			33	50	23	ER32 2÷25	4996	3670	0988
d 44,45 - ER40/L 160	—	3428			40	63	28	ER40 3÷32	4997	3671	0821
d50 - ER 32 / L 125 d50 - ER 32 / L 160	— —	3409 3519			32	50	23	ER32 2÷25	4996	3670	0988
d50 - ER 40 / L 125 d50 - ER 40 / L 160	— —	5197 3412			37	63	28	ER40 3÷32	4997	3671	0821
d 50,8 - ER 32 / L 160	—	3422			32	50	23	ER32 2÷25	4996	3670	0988
d 50,8 - ER 40 / L 160	—	3426			37	63	28	ER40 3÷32	4997	3671	0821
d 60 - ER 32 / L 160	—	3514			32	50	23	ER32 2÷25	4996	3670	0988
d 60 - ER 40 / L 160	—	3515			37	63	28	ER40 3÷32	4997	3671	0821

**DIN
1835 B+E**

**PORTAPINZA ER CON ATTACCO CILINDRICO WE
GHIERA STANDARD**

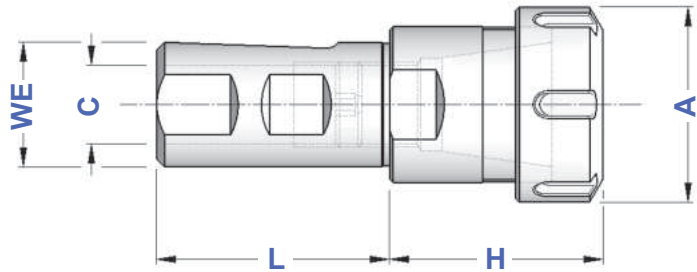
WE SHANK ER COLLET CHUCKS with STANDARD NUT







TIPO	Art.	H	L	A	C	RANGE			
WE 20 - ER 32 / H 55	3313	55	50	50	11	ER32 2÷25	4996	3670	0988
WE 20 - ER 32 / H 100	3314	100	50	50	11	ER32 2÷25	4996	3670	0988
WE 25 - ER 32 / H 55	3320	55	56	50	13	ER32 2÷25	4996	3670	0988
WE 25 - ER 32 / H 100	3321	100	56	50	13	ER32 2÷25	4996	3670	0988
WE 32 - ER 32 / H 55	3323	55	60	50	23	ER32 2÷25	4996	3670	0988
WE 32 - ER 32 / H 100	3324	100	60	50	23	ER32 2÷25	4996	3670	0988

**DIN
1835 A**

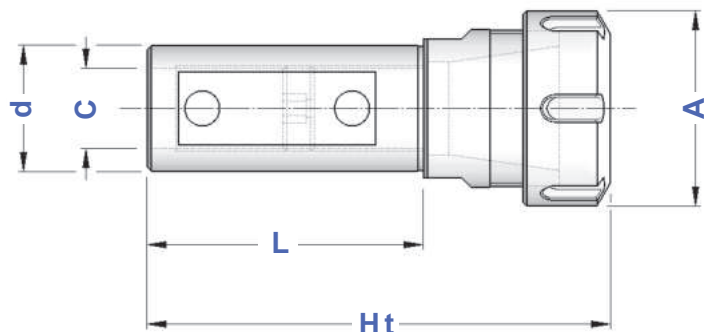
**PORTAPINZA ER CON ATTACCO CILINDRICO E FORI DI LUBRIFICAZIONE
GHIERA STANDARD**

STRAIGHT SHANK ER COLLET CHUCKS with COOLING HOLES - STANDARD NUT



TIPO	Art.	A	Ht	L	C	RANGE			
d 32 NC - ER 25	3408	42	110	70	19	ER25 1÷20	4995	3669	0996
d 32 NC - ER 32	3401	50	118	70	23	ER32 2÷25	4996	3670	0988
d 40 NC - ER 32	3402	50	115	75	23	ER32 2÷25	4996	3670	0988
d 40 NC - ER 40	3404	63	130	75	23	ER40 3÷32	4997	3671	0821

DIN 1835 A

PORTAPINZA ER CON ATTACCO CILINDRICO - GHIERA INTERNA

STRAIGHT SHANK ER COLLET CHUCKS with INNER NUT

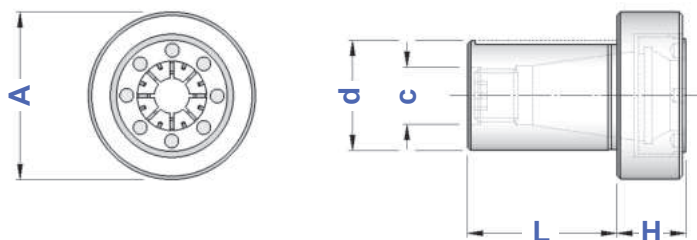

La ghiera tipo "GA" può essere sostituita con la ghiera tipo "GA-E" (pag. 29) che ha presa di chiave esagonale.



Nut "GA" type can be substituted by nut "GA-E" type (pag. 29) with hexagonal wrench hold.



TIPO	Art.	H	L	A	C	RANGE			
d 20 - ER 16 GA	2939	14	34	32	11	ER 16 1÷12	2868	3170	0364
d 25 - ER 20 GA	3200	18	34	38	13	ER 20 1÷15	2869	3171	0787
d 32 - ER 20 GA	2940	16	36	38	13	ER 20 1÷15	2869	3171	0787
d 32 - ER 25 GA	2942	19	36	40	19	ER 25 1÷20	2870	3172	0996
d 40 - ER 32 GA	2943	21	45	48	23	ER 32 2÷25	2871	3173	0998

DIN 1835 → **DIN 238**

ATTACCHI PER MANDRINI AUTOSERRANTI

SHANKS FOR KEYLESS DRILL CHUCKS



TIPO	Art.	d	"B"	L	Lt
d 8 - B10	4023/08 - B10	8	10	35	55
d 10 - B10	4023/10 - B10	10	10	50	70
d 10 - B12	4023/10 - B12	10	12	50	75
d 10 - B16	4023/10 - B16	10	16	50	82
d 12 - B16	4023/12 - B16	12	16	50	82
d 12 - B16	4023/12 - B16L	12	16	60	92
d 16 - B16	4023/16 - B16	16	16	50	81
d 16 - B16	4023/16 - B16L	16	16	70	101
d 20 - B12	4023/20 - B12	20	12	60	85
d 20 - B16	4023/20 - B16	20	16	60	92
d 20 - B18	4023/20 - B18	20	18	60	100
d 25 - B16	4023/25 - B16	25	16	75	107



I Mandrini Autoserranti con attacco DIN 238 si trovano a pagina 62

DIN 238 shank Keyless Drill Chucks you can find at page 62

**DIN
1835 A**

**MANDRINI AUTOSERRANTI INTEGRALI CON ATTACCO CILINDRICO
ROTAZIONE DESTRA**

STRAIGHT SHANK MONOLITHIC DRILL CHUCKS - RIGHT SPIN

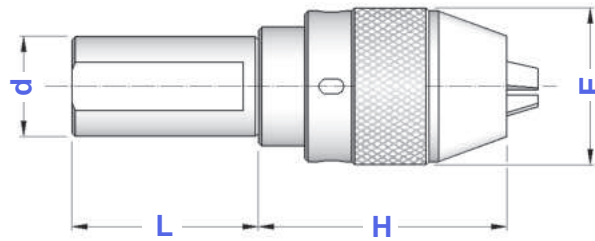

Forniti completi dell'apposita chiave
Supplied complete with suitable wrench

TIPO	Art.	RANGE	E	H	L	
* d 20 - DC 13	1419	0,5 ÷ 13	50	80	60	2370
d 25 - DC 13	1422	0,5 ÷ 13	50	80	80	2370
d 32 - DC 13	1425	0,5 ÷ 13	50	80	60	2370
d 32 - DC 16	1426	3 ÷ 16	57	85	60	2371
d 40 - DC 13	1427	0,5 ÷ 13	50	80	70	2370
d 40 - DC 16	1428	3 ÷ 16	57	85	70	2371

* **Forniti solo con attacco cilindrico SENZA PIANO**
Supplied only with cylindrical connection WITHOUT FLAT

**DIN
1835 A**

**MANDRINI AUTOSERRANTI INTEGRALI CON ATTACCO CILINDRICO
ROTAZIONE DESTRA E SINISTRA**

STRAIGHT SHANK MONOLITHIC DRILL CHUCKS - RIGHT & LEFT SPIN

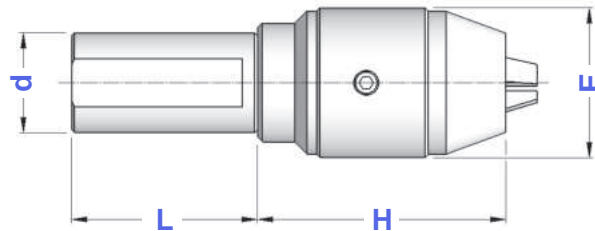

Forniti completi dell'apposita chiave
Supplied complete with suitable wrench

TIPO	Art.	RANGE	E	H	L	
d 25 - DCU13	8607	0,5 ÷ 13	50	85	70	2372
d 25 - DCU16	8608	3 ÷ 16	50	89	70	
d 32 - DCU13	8609	0,5 ÷ 13	50	85	60	2372
d 32 - DCU16	8610	3 ÷ 16	57	89	60	
d 40 - DCU13	8611	0,5 ÷ 13	50	85	70	2372
d 40 - DCU16	8612	3 ÷ 16	57	89	70	



**Le Riduzioni Cilindriche
per DIN 238
si trovano a pagina 41.**

Straight shank adapters
to DIN 238
you can find at page 41.





**I Mandrini Autoserranti
con attacco DIN 238
si trovano a pagina 62**

DIN 238 shank
Keyless Drill Chucks
you can find at page 62

**DIN
1835 B**

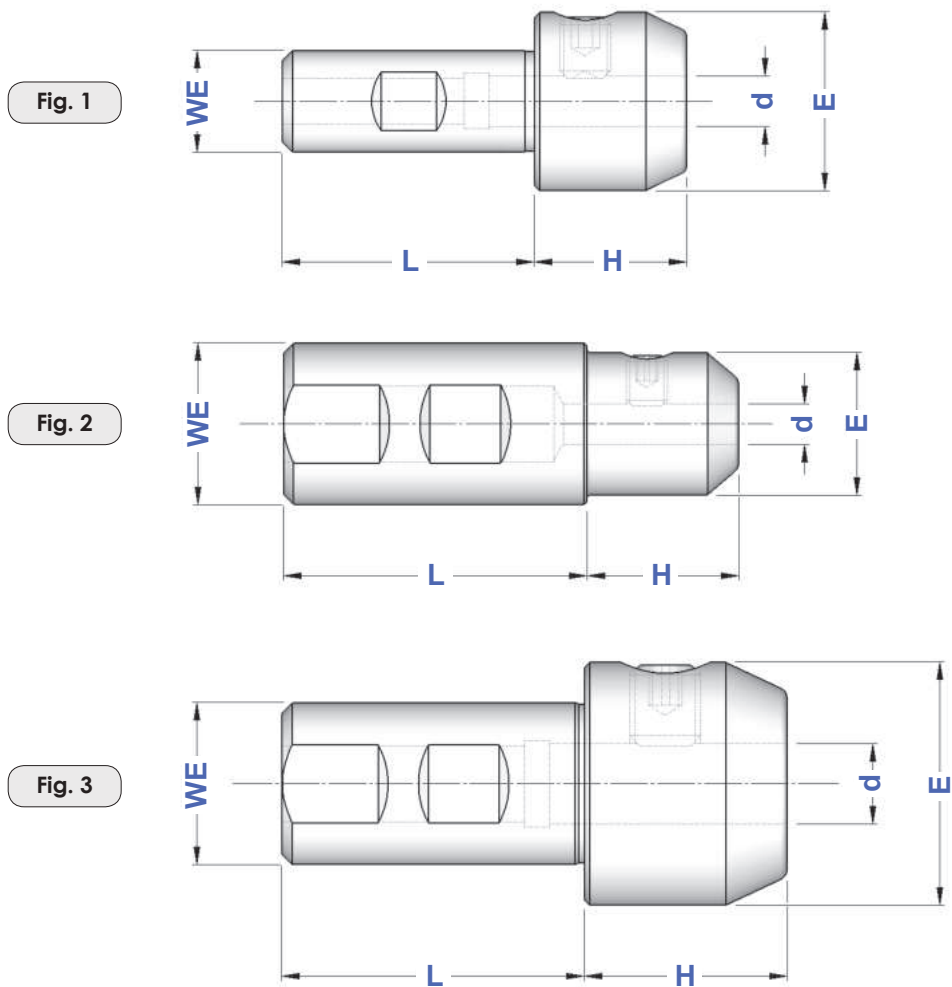
RIDUZIONI WELDON CON ATACCO CILINDRICO
CYLINDRICAL SHANK WELDON REDUCTION SLEEVES



TIPO	Art.	d	H	L	E	Figura	
WE 20 - d 6	3044	6	30	50	25	1	4970
WE 20 - d 8	3046	8	30	50	28	1	4971
WE 20 - d 10	3064	10	30	50	35	1	4972
WE 20 - d 12	3065	12	35	50	42	1	4973
WE 20 - d 14	4518	14	35	50	44	1	4973
WE 20 - d 16	3066	16	60	50	48	1	4974
WE 25 - d 6	3121	6	25	56	25	2	4970
WE 25 - d 8	3122	8	30	56	28	3	4971
WE 25 - d 10	3123	10	30	56	35	3	4972
WE 25 - d 12	3124	12	35	56	42	3	4973
WE 25 - d 14	4519	14	35	56	44	3	4973
WE 25 - d 16	3125	16	40	56	48	3	4974
WE 32 - d 6	3760	6	30	60	25	2	4970
WE 32 - d 8	3761	8	30	60	28	2	4971
WE 32 - d 10	3762	10	30	60	35	3	4972
WE 32 - d 12	3763	12	35	60	42	3	4973
WE 32 - d 14	4520	14	35	60	44	3	4973
WE 32 - d 16	3764	16	40	60	48	3	4974
WE 32 - d 18	4521	18	40	60	50	3	4974
WE 32 - d 20	3765	20	40	60	52	3	4975
WE 32 - d 25	3126	25	65	60	65	3	4976

**DIN
1835 A**

**MASCHIATORI ATTACCO CILINDRICO
DOPPIA COMPENSAZIONE**
STRAIGHT SHANK TAPPING CHUCKS - DOUBLE COMPENSATION

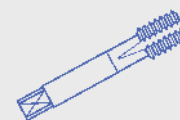

TIPO	Art.	H	L	E	B	COMPENSAZIONE	
d 16 - B.0	3807	37	56	26	13	- 6,5 + 6,5	M 1 ÷ M 10
d 16 - B.1	3808	39	56	36	19	- 7,5 + 7,5	M 3 ÷ M 12 (*M18)
d 20 - B.0	3809	37	56	26	13	- 6,5 + 6,5	M 1 ÷ M 10
d 20 - B.1	3851	40	50	38	19	- 7,5 + 7,5	M 3 ÷ M 12 (*M18)
d 20 - B.2	3852	63	50	53	31	-12,5 +12,5	M 6 ÷ M 20 (*M30)
d 25 - B.1	4451	40	53	38	19	- 7,5 + 7,5	M 3 ÷ M 12 (*M18)
d 25 - B.2	4452	63	53	53	31	-12,5 +12,5	M 6 ÷ M 20 (*M30)
d 32 - B.1	4453	40	60	38	19	- 7,5 + 7,5	M 3 ÷ M 12 (*M18)
d 32 - B.2	4454	63	77	53	31	-12,5 +12,5	M 6 ÷ M 20 (*M30)
d 32 - B.3	4486	98	100	79	48	-20,0 +20,0	M14 ÷ M 33 (*M48)
d 40 - B.1	4455	40	58	38	19	- 7,5 + 7,5	M 3 ÷ M 12 (*M18)
d 40 - B.2	4456	63	77	53	31	-12,5 +12,5	M 6 ÷ M 20 (*M30)
d 40 - B.3	4487	98	100	79	48	-20,0 +20,0	M14 ÷ M 33 (*M48)

* Bussole con GRANI
Adapters with SCREWS

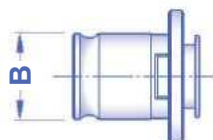
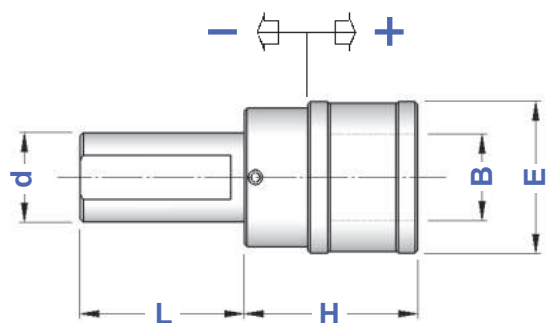

**Bussole a maschiare
da pag. 235**

Tapping Adapters
from page 235

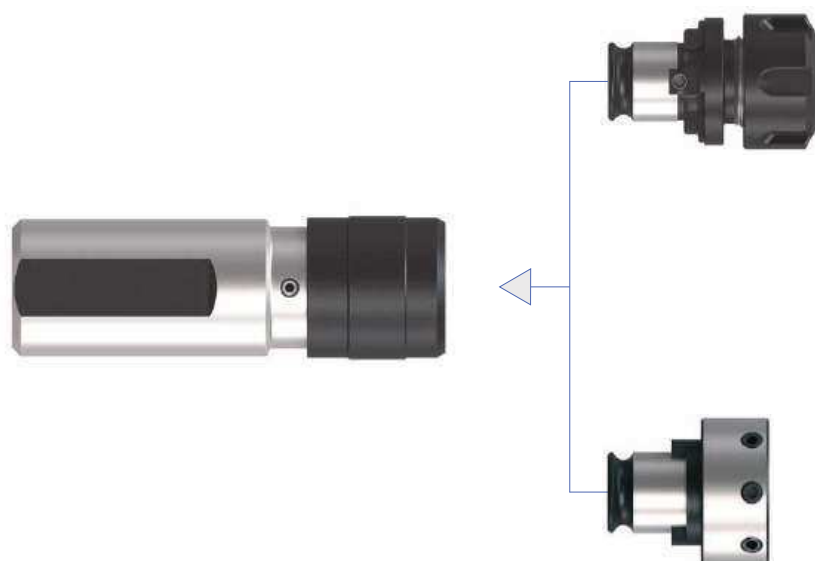

**Bussole porta Maschi
con pinza ER
pag. 238**

Tapping adapters
with ER collet
page 238



**Bussole
porta FILIERE
pag. 238**

Threading Die
Adapters
page 238

DIN 1835 B+E

**MASCHIATORI ATTACCO CILINDRICO WE
DOPPIA COMPENSAZIONE**

WE SHANK TAPPING CHUCKS - DOUBLE COMPENSATION

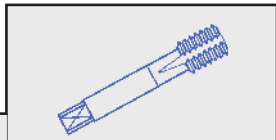

TIPO	Art.	H	L	E	B	COMPENSAZIONE	
WE 20 - B.0	3127	37	50	26	13	- 6,5 + 6,5	M 1 ÷ M 10
WE 20 - B.1	3176	40	50	38	19	- 7,5 + 7,5	M 3 ÷ M 12 (*M18)
WE 20 - B.2	3179	63	50	53	31	-12,5 + 12,5	M 6 ÷ M 20 (*M30)
WE 25 - B.1	3963	40	53	38	19	- 7,5 + 7,5	M 3 ÷ M 12 (*M18)
WE 25 - B.2	3964	63	53	53	31	-12,5 + 12,5	M 6 ÷ M 20 (*M30)
WE 32 - B.1	3853	40	60	38	19	- 7,5 + 7,5	M 3 ÷ M 12 (*M18)
WE 32 - B.2	3854	63	60	53	31	-12,5 + 12,5	M 6 ÷ M 20 (*M30)
WE 32 - B.3	3598	120	60	79	48	-20,0 + 20,0	M14 ÷ M 33 (*M48)
WE 40 - B.1	3855	40	72	38	19	- 7,5 + 7,5	M 3 ÷ M 12 (*M18)
WE 40 - B.2	3856	63	72	55	31	-12,5 + 12,5	M 6 ÷ M 20 (*M30)
WE 40 - B.3	3857	98	72	79	48	-20,0 + 20,0	M14 ÷ M 33 (*M48)

* Bussole con GRANI
Adapters with SCREWS

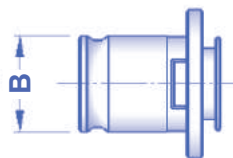
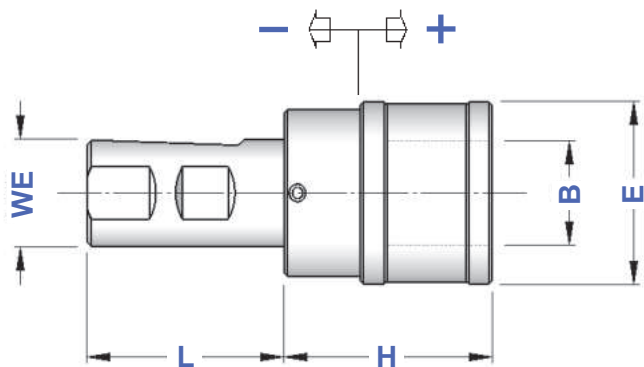

Bussole a maschiare da pag. 235
Tapping Adapters from page 235

DIN 1835 B+E

**MASCHIATORI ATTACCO CILINDRICO WE
SENZA COMPENSAZIONE**

WE SHANK TAPPING CHUCKS - WITHOUT COMPENSATION

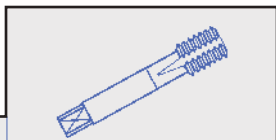

TIPO	Art.	H	L	E	B	
WE 20 - B.1 FISSO	2059	40	50	33	19	M 3 ÷ M 12 (*M18)
WE 20 - B.2 FISSO	2060	60	50	50	31	M 6 ÷ M 20 (*M30)
WE 25 - B.1 FISSO	2061	40	56	33	19	M 3 ÷ M 12 (*M18)
WE 25 - B.2 FISSO	2062	60	56	50	31	M 6 ÷ M 20 (*M30)
WE 32 - B.1 FISSO	2067	40	60	33	19	M 3 ÷ M 12 (*M18)
WE 32 - B.2 FISSO	2068	60	60	50	31	M 6 ÷ M 20 (*M30)
WE 40 - B.1 FISSO	2080	40	72	33	19	M 3 ÷ M 12 (*M18)
WE 40 - B.2 FISSO	2081	60	72	50	31	M 6 ÷ M 20 (*M30)

* Bussole con GRANI
Adapters with SCREWS

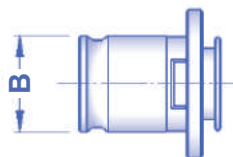
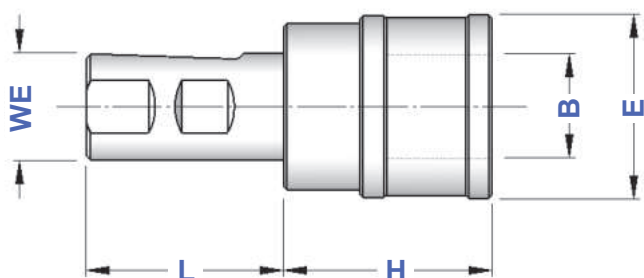

Bussole a maschiare da pag. 235
Tapping Adapters from page 235

**PORTAFRESE ATTACCO CILINDRICO DIN 1835 B
PER FRESE CON ATTACCO FILETTATO**

DIN 1835 B SHANKS FOR
MILLING CUTTERS WITH THREADED SHANK

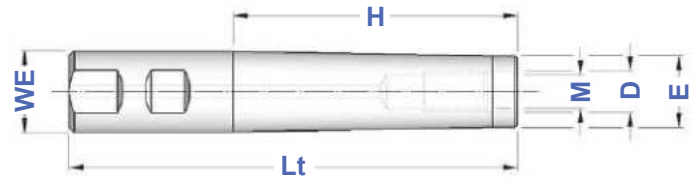

TIPO	Art.	M	D	E	H	Lt
WE16 - M 8	6480	M8	8,5	12,8	60	115
WE16 - M 8	6481	M8	8,5	12,8	100	160
WE20 - M10	6482	M10	10,5	17,8	60	120
WE20 - M10	6483	M10	10,5	17,8	100	160
WE25 - M12	6484	M12	12,5	20,8	100	160
WE32 - M16	6485	M16	17,0	28,8	100	160

PROLUNGHE PER FRESE CON ATTACCO FILETTATO

EXTENSIONS FOR MILLING CUTTERS WITH THREADED SHANK

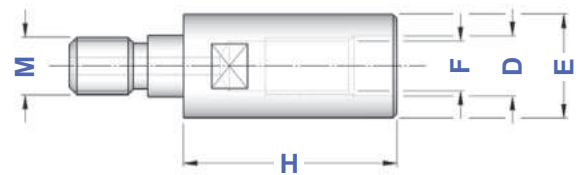

TIPO	Art.	M	F	D	E	H
M 8 - M 8	6486	M8	M8	8,5	12,8	30
M 10 - M 10	6487	M10	M10	10,5	17,8	35
M 12 - M 12	6488	M12	M12	12,5	20,8	40
M 16 - M 16	6489	M16	M16	17,0	28,8	40

RIDUZIONI PER FRESE CON ATTACCO FILETTATO

REDUCTIONS FOR MILLING CUTTERS WITH THREADED SHANK

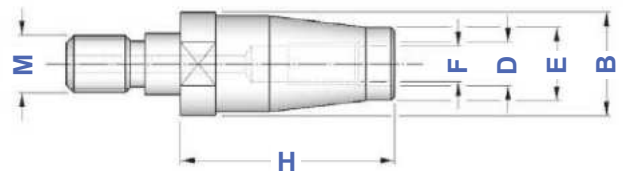



TIPO	Art.	M	F	D	E	B	H
M 10 - M 8	6490	M10	M8	8,5	12,8	17,8	30
M 12 - M 8	6491	M12	M8	8,5	12,8	20,8	40
M 12 - M 10	6492	M12	M10	10,5	17,8	20,8	35
M 16 - M 10	6493	M16	M10	10,5	17,8	28,8	60
M 16 - M 12	6494	M16	M12	12,5	20,8	28,8	40

PORTAPINZE ER CON ATTACCO FILETTATO

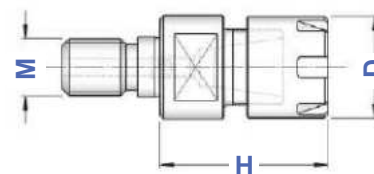
ER COLLET CHUCKS WITH THREADED SHANK



TIPO	Art.	M	D	H	RANGE			
M 12 - ER 16 GM	6460	M12	22	35	ER 16 1÷12	1229	5719	0364
M 16 - ER 16 GM	6461	M16	22	40	ER 16 1÷12	1229	5719	0364
M 16 - ER 20 GM	6462	M16	28	40	ER 20 1÷15	1230	5720	0787
M 16 - ER 25 GM	6463	M16	35	45	ER 25 1÷20	1231	5721	0996

INDICE DELL' ATTACCO TRAPEZIO DIN 6327

INDEX OF TRAPEZOIDAL SHANK DIN 6327

PORTAPINZA ER ghiera MINI

ER MINI NUT
COLLET CHUCKS
pag. 48



PORTAPINZA ER ghiera ESAGONALE

ER HEXAGONAL NUT
COLLET CHUCKS
pag. 48



PORTAPINZA ER ghiera STANDARD

ER STANDARD NUT
COLLET CHUCKS
pag. 49



GHIERE di REGISTRAZIONE

ADJUSTING NUTS

pag. 49



attacchi per AUTOSERRANTI

SHANKS for
DIN 238 DRILL CHUCKS
pag. 49



ASTUCCI REGISTRABILI a cono morse - tipo "E"

ADJUSTABLE MT ADAPTERS
"E" type
pag. 50



ASTUCCI REGISTRABILI a cono morse - tipo "G"

ADJUSTABLE MT ADAPTERS
"G" type
pag. 50



MASCHIATORI

TAPPING CHUCKS

pag. 51



INDICE DELL' ATTACCO DIN 238

INDEX OF DIN 238 SHANK

PORTAPINZA ER ER COLLET CHUCKS

pag. 52



MASCHIATORI

TAPPING CHUCKS

pag. 52



AUTOSERRANTI KEYLESS DRILL CHUCKS

pag. 62



AUTOSERRANTI ALTA PRECISIONE

HIGH PRECISION
KEYLESS DRILL CHUCKS
pag. 62



**DIN
6327**

PORTAPINZA ER CON ATTACCO TRAPEZIO - GHIERA MINI

TRAPEZOIDAL SHANK ER COLLET CHUCKS with MINI NUT

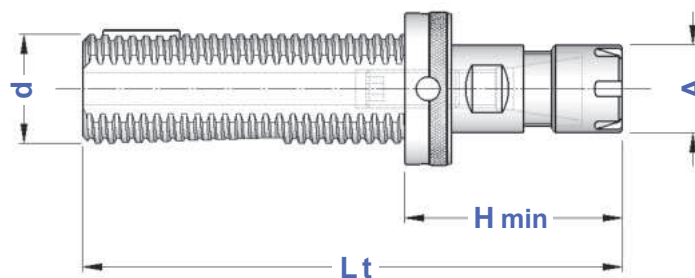

TIPO	Art.	d	Lt	H MIN	A	RANGE					
TR 8 - ER 8 GM	3146	8	75	35	12	ER 8 1÷5	2964	0101	0373	5717	0554
TR10 - ER11 GM	3147	10	95	45	16	ER 11 1÷8	2965	0103	0432	5718	5573
TR12 - ER11 GM	3148	12	95	45	16	ER 11 1÷8	2966	0103	0432	5718	5573
TR12 - ER16 GM	3149	12	103	53	22	ER 16 1÷12	2966	0103	1229	5719	0364
TR16 - ER16 GM	3150	16	120	47	22	ER 16 1÷12	2967	0107	1229	5719	0364
TR16 - ER20 GM	3151	16	130	57	28	ER 20 1÷15	2967	0107	1230	5720	0787
TR20 - ER16 GM	3153	20	135	59	22	ER 16 1÷12	2968	0107	1229	5719	0364
TR20 - ER20 GM	3154	20	135	59	28	ER 20 1÷15	2968	0107	1230	5720	0787
TR20 - ER25 GM	3155	20	135	59	35	ER 25 1÷20	2968	0107	1231	5721	0996

Forniti completi di ghiera di registrazione
Supplied complete with adjustment nut

**DIN
6327**

PORTAPINZA ER CON ATTACCO TRAPEZIO - GHIERA ESAGONALE

TRAPEZOIDAL SHANK ER COLLET CHUCKS with HEXAGONAL NUT

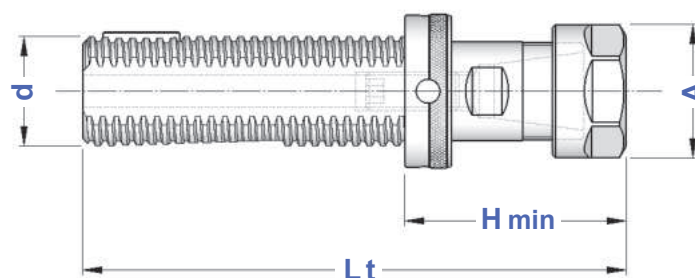

TIPO	Art.	d	Lt	H MIN	A	RANGE					
TR 16 - ER11 GE	3137	16	110	37	19	ER 11 1÷8	2967	0107	1157	2905	5573
TR 16 - ER16 GE	3138	16	122	49	28	ER 16 1÷12	2967	0107	1214	2906	0364
TR 20 - ER16 GE	3139	20	128	52	28	ER 16 1÷12	2968	0107	1214	2906	0364
TR 20 - ER20 GE	3140	20	135	59	34	ER 20 1÷15	2968	0107	1215	2907	0787
TR 28 - ER20 GE	3141	28	140	57	34	ER 20 1÷15	2969	0108	1215	2907	0787

Forniti completi di ghiera di registrazione
Supplied complete with adjustment nut

**DIN
6327**

PORTAPINZA ER CON ATTACCO TRAPEZIO - GHIERA STANDARD

TRAPEZOIDAL SHANK ER COLLET CHUCKS with STANDARD NUT

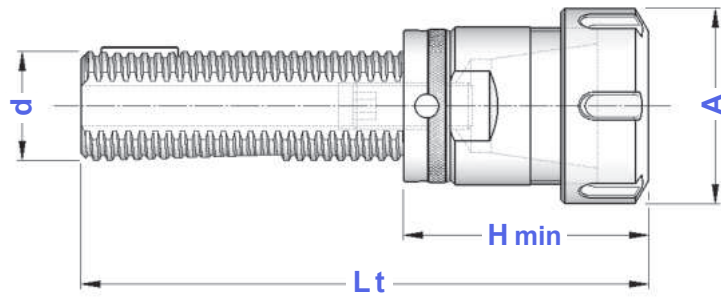

TIPO	Art.	d	Lt	H MIN	A	RANGE					
TR 28 - ER 25	3142	28	140	57	42	ER25 1÷20	2969	0108	4995	3669	0996
TR 28 - ER 32	3143	28	147	64	50	ER32 2÷25	2969	0108	4996	3670	0988
TR 28 - ER 40	3162	28	190	107	63	ER40 3÷32	2969	0108	4997	3671	0821
TR 36 - ER 25	3973	36	163	57	42	ER25 1÷20	2970	0111	4995	3669	0996
TR 36 - ER 32	3144	36	165	61	50	ER32 2÷25	2970	0111	4996	3670	0988
TR 36 - ER 40	3145	36	186	82	63	ER40 3÷32	2970	0111	4997	3671	0821
TR 48 - ER 32	3667	48	200	74	50	ER32 2÷25	2971	0114	4996	3670	0988

Forniti completi di ghiera di registrazione
Supplied complete with adjustment nut

**DIN
6327**

GHIERE DI REGISTRAZIONE DIN 6327

DIN 6327 ADJUSTMENT NUTS

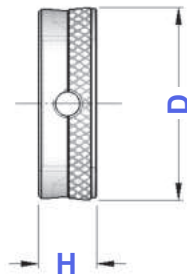

TIPO	Art.	H	D	
GH - TR 8 x 1	2964	10	14,8	0011
GH - TR10 x1,5	2965	12	17,8	0017
GH - TR12 x1,5	2966	12	19,7	0017
GH - TR16 x1,5	2967	12	24,6	0019
GH - TR20 x 2	2968	12	31,6	0019
GH - TR28 x 2	2969	12	39,6	0020
GH - TR36 x 2	2970	14	49,6	0020
GH - TR48 x 2	2971	18	66,6	0021

**DIN
6327**

ATTACCHI PER MANDRINI AUTOSERRANTI

SHANKS FOR DRILL CHUCKS DIN 238 / ISO 239 TYPE

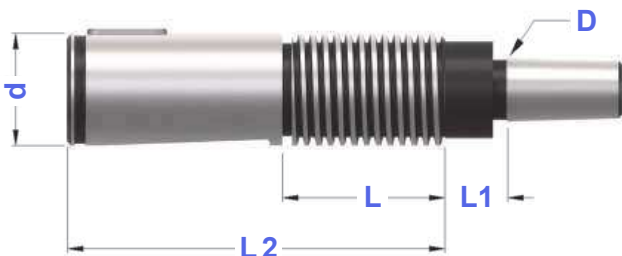

TIPO	Art.	d	L	L1	L2	D	
TR 28 - B16	2774	28	42	21	95	15,733	2969
TR 36 - B16	2775	36	50	21	118	15,733	2970



**DIN
6327**

ASTUCCI REGISTRABILI A CONO MORSE - TIPO "E"
DIN 6327 ADJUSTABLE MORSE TAPER ADAPTERS - "E" TYPE

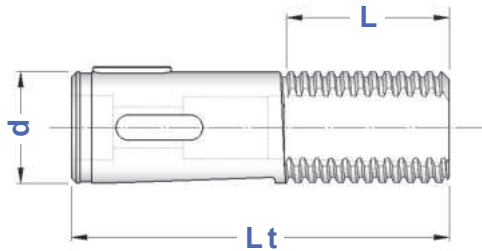

TIPO	Art.	d	L	Lt	
E 16 x 1	2984	16	40	85	2967
E 20 x 1	2985	20	40	88	2968
E 28 x 1	2986	28	42	95	2969
E 28 x 2	3167	28	42	95	2969
E 36 x 2	3168	36	50	118	2970
E 36 x 3	3410	36	50	118	2970
E 48 x 2	3198	48	65	144	2971
E 48 x 3	3411	48	65	144	2971
E 48 x 4	3413	48	65	144	2971



**DIN
6327**

ASTUCCI REGISTRABILI A CONO MORSE - TIPO "G"
DIN 6327 ADJUSTABLE MORSE TAPER ADAPTERS - "G" TYPE

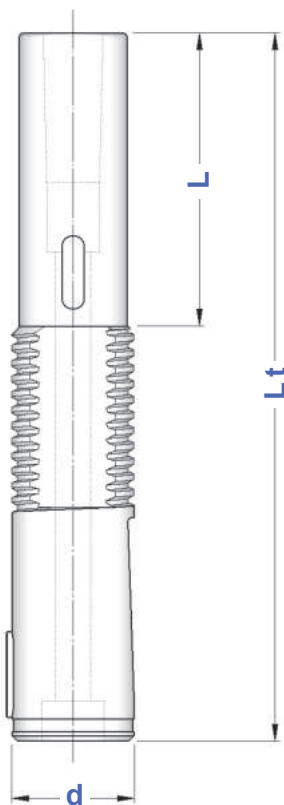

TIPO	Art.	d	L	Lt	
G 16 x 1 x 25	5340	16	25	110	2967
G 16 x 1 x 50	5341		50	135	
G 16 x 1 x 75	5342		75	160	
G 16 x 1 x 100	5343		100	185	
G 20 x 1 x 25	5344	20	25	113	2968
G 20 x 1 x 50	5345		50	138	
G 20 x 1 x 75	5346		75	163	
G 20 x 1 x 100	5347		100	188	
G 28 x 1 x 25	5348	28	25	120	2969
G 28 x 1 x 50	5349		50	145	
G 28 x 1 x 75	5350		75	170	
G 28 x 1 x 100	5351		100	195	
G 28 x 2 x 25	5352	28	25	120	2969
G 28 x 2 x 50	5353		50	145	
G 28 x 2 x 75	5354		75	170	
G 28 x 2 x 100	5355		100	195	
G 36 x 2 x 30	5356	36	30	148	2970
G 36 x 2 x 60	5357		60	178	
G 36 x 2 x 90	5358		90	208	
G 36 x 2 x 120	5359		120	238	
G 36 x 3 x 30	5360	36	30	148	2970
G 36 x 3 x 60	5361		60	178	
G 36 x 3 x 90	5362		90	208	
G 36 x 3 x 120	5363		120	238	
G 48 x 3 x 40	5364	48	40	184	2971
G 48 x 3 x 80	5365		80	224	
G 48 x 3 x 120	5366		120	264	
G 48 x 3 x 160	5367		160	304	
G 48 x 4 x 40	5368	48	40	184	2971
G 48 x 4 x 80	5372		80	224	
G 48 x 4 x 120	5373		120	264	
G 48 x 4 x 160	5374		160	304	



**DIN
6327**

**MASCHIATORI ATTACCO TRAPEZIO A CAMBIO RAPIDO
DOPPIA COMPENSAZIONE**

DOUBLE COMPENSATION QUICK CHANGE TAPPING CHUCKS

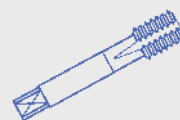

TIPO	Art.	d	H MIN	E	B	COMPENSAZIONE	
TR 16 - B. 0	3811	16	49	26	13	- 6,5 + 6,5	M 1 ÷ M 10
TR 16 - B. 1	3564	16	51	36	19	- 7,5 + 7,5	M 3 ÷ M 12 (*M18)
TR 20 - B. 0	3156	20	49	26	13	- 6,5 + 6,5	M 1 ÷ M 10
TR 20 - B. 1	3565	20	51	38	19	- 7,5 + 7,5	M 3 ÷ M 12 (*M18)
TR 20 - B. 2	3926	20	75	55	31	-12,5 +12,5	M 6 ÷ M 20 (*M30)
TR 28 - B. 1	3566	28	51	38	19	- 7,5 + 7,5	M 3 ÷ M 12 (*M18)
TR 28 - B. 2	3567	28	76	55	31	-12,5 +12,5	M 6 ÷ M 20 (*M30)
TR 28 - B. 3	3220	28	108	79	48	-20,0 +20,0	M14 ÷ M 33 (*M48)
TR 36 - B. 1	3568	36	53	38	19	- 7,5 + 7,5	M 3 ÷ M 12 (*M18)
TR 36 - B. 2	3569	36	78	55	31	-12,5 +12,5	M 6 ÷ M 20 (*M30)
TR 36 - B. 3	3570	36	110	79	48	-20,0 +20,0	M14 ÷ M 33 (*M48)
TR 48 - B. 3	3571	48	114	79	48	20,0 +20,0	M14 ÷ M 33 (*M48)

Forniti completi di ghiera di registrazione
Supplied complete with adjustment nut

* Bussole con GRANI
Adapters with SCREWS

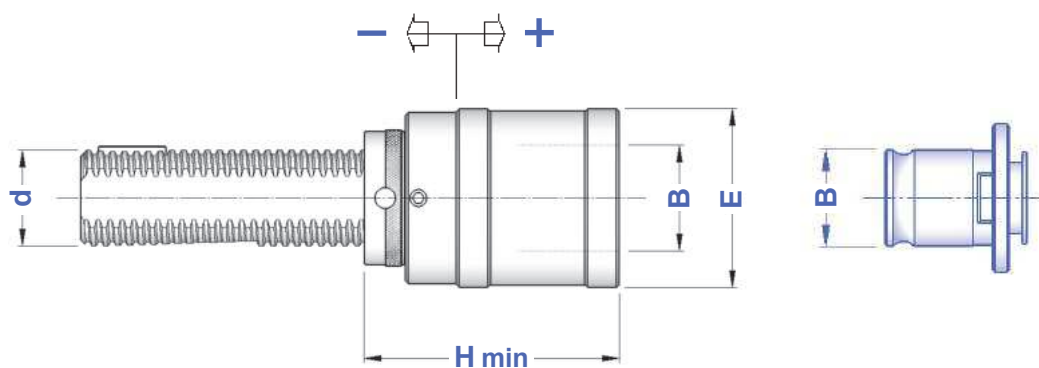

**DIN
6327**

**MASCHIATORI ATTACCO TRAPEZIO A CAMBIO RAPIDO
SENZA COMPENSAZIONE**

QUICK CHANGE TAPPING CHUCKS WITHOUT COMPENSATION

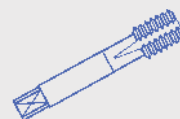

TIPO	Art.	d	H MIN	E	B	
TR 16 - B.0 FISSO	5198	16	45	23	13	M 1 ÷ M 10
TR 16 - B.1 FISSO	5199	16	49	32	19	M 3 ÷ M 12 (*M18)
TR 20 - B.1 FISSO	5211	20	49	32	19	M 3 ÷ M 12 (*M18)
TR 20 - B.2 FISSO	5212	20	66	50	31	M 6 ÷ M 20 (*M30)
TR 28 - B.1 FISSO	5213	28	49	32	19	M 3 ÷ M 12 (*M18)
TR 28 - B.2 FISSO	5214	28	66	50	31	M 6 ÷ M 20 (*M30)
TR 36 - B.1 FISSO	5215	36	49	32	19	M 3 ÷ M 12 (*M18)
TR 36 - B.2 FISSO	5216	36	68	50	31	M 6 ÷ M 20 (*M30)

Forniti completi di ghiera di registrazione
Supplied complete with adjustment nut

* Bussole con GRANI
Adapters with SCREWS

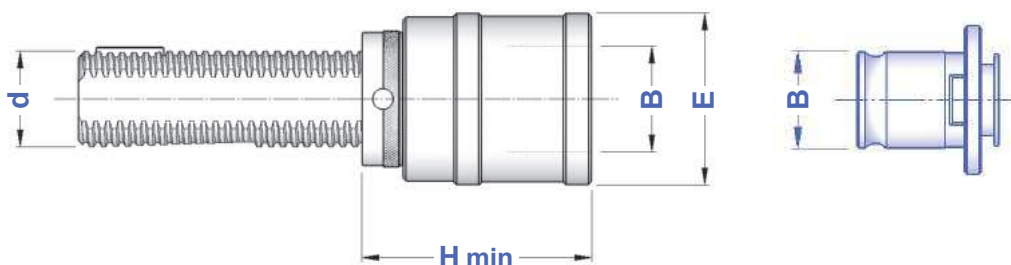

DIN 238
ISO 239

PORTAPINZA ER ATTACCO DIN 238 - GHIERA MINI
ER COLLET CHUCKS with MINI NUT

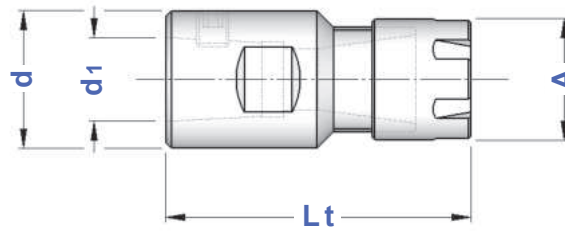

TIPO	Art.	Lt	d1	d	A	RANGE			
"B12" - ER 11 GM	3193	63	12,06	25	16	ER 11 1÷8	0432	5718	5573
"B12" - ER 16 GM	3194	55	12,06	25	22	ER 16 1÷12	1229	5719	0364
"B12" - ER 20 GM	3221	67	12,06	25	28	ER 20 1÷15	1230	5720	0787
"B16" - ER 16 GM	3195	85	15,73	25	22	ER 16 1÷12	1229	5719	0364
"B16" - ER 20 GM	3196	80	15,73	25	28	ER 20 1÷15	1230	5720	0787
"B18" - ER 20 GM	3197	74	17,78	28	28	ER 20 1÷15	1230	5720	0787

DIN 238
ISO 239

MASCHIATORI SENZA COMPENSAZIONE ATTACCO DIN 238
TAPPING CHUCKS WITHOUT COMPENSATION

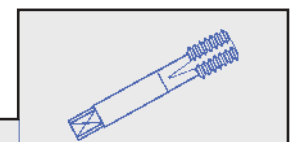
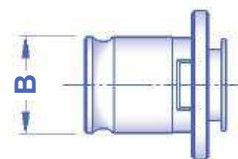
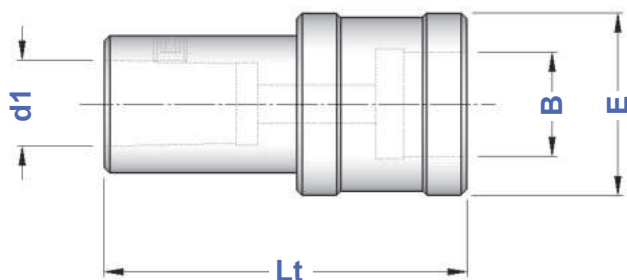

TIPO	Art.	Lt	d1	E	B	
"B12" - B.0 FISSO	0244	55	12,06	26	13	M 1 ÷ M 10
"B12" - B.1 FISSO	0320	59	12,06	33	19	M 3 ÷ M 12 (*M18)
"B16" - B.1 FISSO	0340	65	15,73	33	19	M 3 ÷ M 12 (*M18)
"B16" - B.2 FISSO	0071	84	15,73	50	31	M 6 ÷ M 20 (*M30)
"B18" - B.1 FISSO	0384	73	17,78	33	19	M 3 ÷ M 12 (*M18)
"B18" - B.2 FISSO	0072	92	17,78	50	31	M 6 ÷ M 20 (*M30)

* Bussole con GRANI
Adapters with SCREWS

CARATTERISTICHE TECNICHE CONO MORSE DIN 228-A (CON FILETTO)

MORSE TAPER DIN 228-A STANDARD FEATURES (with THREAD)

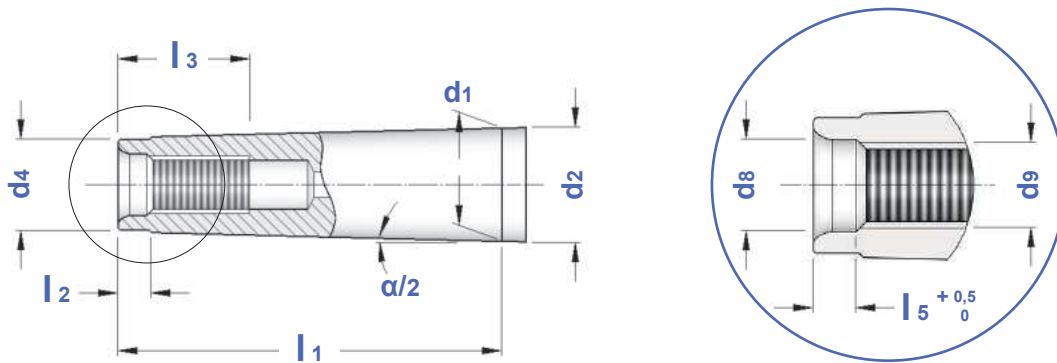

CONO	d1	d2	d4	d8	d9	l1	l2	l3	l5	$\alpha/2$
CM 0	9,045	9,2	6	–	–	50	4	–	–	1° 29' 27"
CM 1	12,065	12,2	9	6,4	M 6	53,5	5	16	4	1° 25' 43"
CM 2	17,780	18	14	10,5	M 10	64	5	24	5	1° 25' 50"
CM 3	23,825	24,1	19	13	M 12	81	7	24	5,5	1° 26' 16"
CM 4	31,267	31,6	25	17	M 16	102,5	9	32	8,2	1° 29' 15"
CM 5	44,399	44,7	35,7	21	M 20	129,5	10	40	10	1° 30' 26"
CM 6	63,348	63,8	51	25	M 24	182	16	47	11,5	1° 29' 36"

CARATTERISTICHE TECNICHE CONO MORSE DIN 228-B (CON TENONE)

MORSE TAPER DIN 228-B STANDARD FEATURES (with TONQUE)

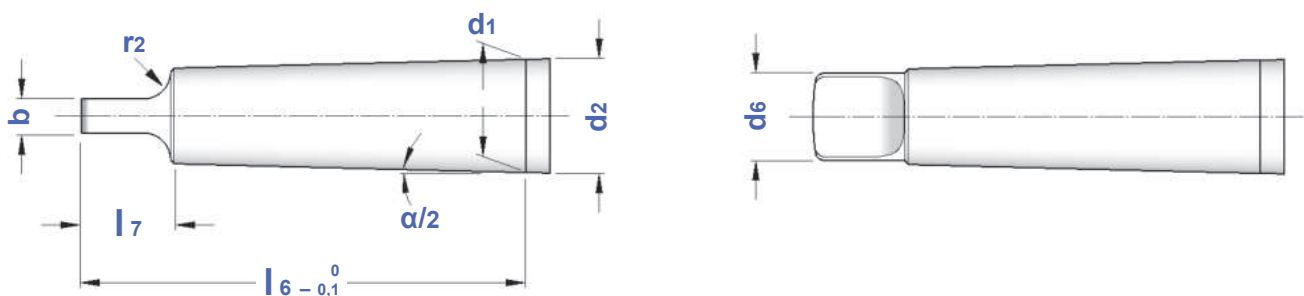

CONO	b	d1	d2	d6	l6	l7	r2	$\alpha/2$
CM 0	3,9	9,045	9,2	6	56,5	10,5	4	1° 29' 27"
CM 1	5,2	12,065	12,2	8,7	62	13,5	5	1° 25' 43"
CM 2	6,3	17,780	18	13,5	75	16	6	1° 25' 50"
CM 3	7,9	23,825	24,1	18,5	94	20	7	1° 26' 16"
CM 4	11,9	31,267	31,6	24,5	117,5	24	8	1° 29' 15"
CM 5	15,9	44,399	44,7	35,7	149,5	29	10	1° 30' 26"
CM 6	19	63,348	63,8	51	210	40	13	1° 29' 36"

INDICE DELL' ATTACCO CONO MORSE

INDEX OF MORSE TAPER SHANK DIN 228

**PORTAPINZA ER
ghiera MINI**ER MINI NUT
COLLET CHUCKS
pag. 56**PORTAPINZA ER
ghiera STANDARD**ER STANDARD NUT
COLLET CHUCKS
pag. 58 - 59**TENONI per CONO MORSE**TONQUES
pag. 60**MANDRINI
AUTOSERRANTI**KEYLESS DRILL CHUCKS
pag. 62**PINZE CONO MORSE
DIN 6328 - DIN 6329**MT COLLETS for TWIST DRILLS
and MILLING CUTTERS
pag. 64**PORTA ALESATORI
OSCILLANTI**FLOATING REAMER HOLDERS
pag. 65**BROCCIATORI
POLIGONATORI**BROACHING TOOL HOLDERS
pag. 66**MASCHIATORI
TAPPING CHUCKS**

pag. 68 - 69

**PORTAPINZA ER
ghiera ESAGONALE**ER HEXAGONAL NUT
COLLET CHUCKS
pag. 57**PORTAFRESE WELDON**END MILL HOLDERS
for DIN 1835-B SHANK

pag. 60

**AUTOSERRANTI INTEGRALI**MONOLITHIC DRILL CHUCKS
pag. 61**attacchi per MANDRINI
AUTOSERRANTI**SHANKS for DIN 238
DRILL CHUCKS
pag. 63**PINZE CONO MORSE
con FILETTO**THREADED MT COLLETS
pag. 64**PORTA ALESATORI
a MANICOTTO**SHELL REAMER HOLDERS
pag. 65**PORTAFRESE COMBINATI**COMBI SHELL MILL HOLDERS
pag. 67**PORTA FILIERA**THREADING DIE HOLDERS
pag. 70

➔ segue
continue

**TAMPONI PULITORI
per SEDE CONO MORSE**

CLEANERS for
MORSE TAPER SEAT
pag. 70



riduzioni con ESTRATTORE

MORSE TAPER SLEEVES
with RELEASE NUT

pag. 71



**riduzioni PROLUNGATE
e prolunghe EXTRALUNGHE**

MT EXTENDED ADAPTERS and
EXTRA-EXTENDED EXTENSIONS
pag. 72 - 73



riduzioni PASSANTI

OPEN-ENDED
MORSE TAPER SLEEVES

pag. 71



riduzioni DIN 2185

MT ADAPTERS SLEEVES

pag. 72



CACCIACONI

CONE EJECTORS

pag. 73



CONTROPUNTE

TAILSTOCKS

CONTROPUNTE

TAILSTOCKS

pag. 74



**CONTROPUNTE
per RETTIFICA**

TAILSTOCKS for
GRINDING

pag. 74



**CONTROPUNTE
con ESTRATTORE**

TAILSTOCKS with
RELEASE NUT
pag. 75



CONTROPUNTE ROTANTI

REVOLVING TAILSTOCKS

pag. 76 - 77



DIN 228-A

PORTAPINZA ER ATTACCO CONO MORSE CON FILETTO - GHIERA MINI

MORSE TAPER SHANK ER COLLET CHUCKS with THREAD - MINI NUT

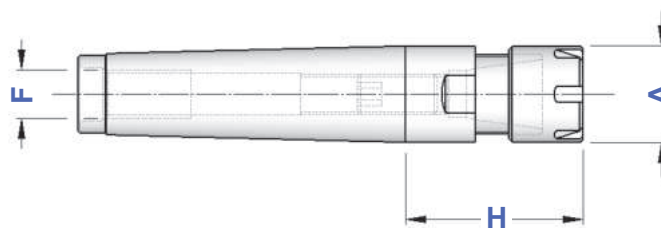

TIPO	Art.	H	A	F	RANGE			
CM 1 A - ER 11 GM	3509	25	16	M 6	ER 11 1÷8	0432	5718	5573
CM 1 A - ER 16 GM	3510	40	22	M 6	ER 16 1÷12	1229	5719	0364
CM 2 A - ER 16 GM	3511	42	22	M10	ER 16 1÷12	1229	5719	0364
CM 2 A - ER 20 GM	3512	50	28	M10	ER 20 1÷15	1230	5720	0787
CM 2 A - ER 25 GM	3513	54	35	M10	ER 25 1÷20	1231	5721	0996
CM 3 A - ER 16 GM	3516	43	22	M12	ER 16 1÷12	1229	5719	0364
CM 3 A - ER 20 GM	3517	47	28	M12	ER 20 1÷15	1230	5720	0787
CM 3 A - ER 25 GM	3518	58	35	M12	ER 25 1÷20	1231	5721	0996

DIN 228-B

PORTAPINZA ER ATTACCO CONO MORSE CON TENONE - GHIERA MINI

MORSE TAPER SHANK ER COLLET CHUCKS with TONQUE - MINI NUT

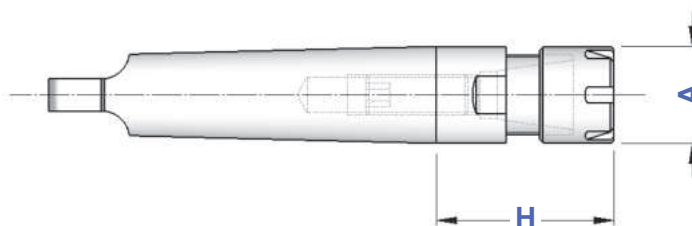





TIPO	Art.	H	A	RANGE			
CM 1 - ER 11 GM	8613	25	16	ER 11 1÷8	0432	5718	5573
CM 1 - ER 16 GM	8614	40	22	ER 16 1÷12	1229	5719	0364
CM 2 - ER 16 GM	8615	42	22	ER 16 1÷12	1229	5719	0364
CM 2 - ER 20 GM	8616	50	28	ER 20 1÷15	1230	5720	0787
CM 2 - ER 25 GM	8617	54	35	ER 25 1÷20	1231	5721	0996
CM 3 - ER 16 GM	8618	43	22	ER 16 1÷12	1229	5719	0364
CM 3 - ER 20 GM	8619	47	28	ER 20 1÷15	1230	5720	0787
CM 3 - ER 25 GM	8620	58	35	ER 25 1÷20	1231	5721	0996

DIN 228-A

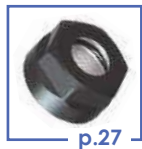
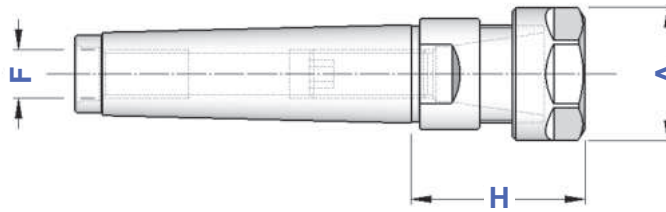
PORTAPINZA ER ATTACCO CONO MORSE CON FILETTO - GHIERA ESAGONALE

MORSE TAPER SHANK ER COLLET CHUCKS with THREAD - HEXAGONAL NUT







TIPO	Art.	H	A	F	RANGE			
CM 1 A - ER16 GE	8621	40	28	M 6	ER16 1÷12	1214	2906	0364
CM 2 A - ER16 GE	8622	42	28	M10	ER16 1÷12	1214	2906	0364
CM 2 A - ER20 GE	8623	50	34	M10	ER20 1÷15	1215	2907	0787

DIN 228-B

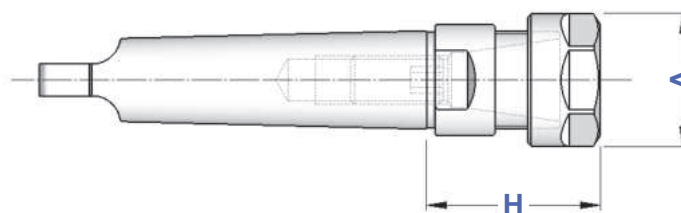
PORTAPINZA ER ATTACCO CONO MORSE CON TENONE - GHIERA ESAGONALE

MORSE TAPER SHANK ER COLLET CHUCKS with TONQUE - HEXAGONAL NUT



TIPO	Art.	H	A	RANGE			
CM 1 - ER 16 GE	8624	40	28	ER 16 1÷12	1214	2906	0364
CM 2 - ER 16 GE	8625	42	28	ER 16 1÷12	1214	2906	0364
CM 2 - ER 20 GE	8626	50	34	ER 20 1÷15	1215	2907	0787

**DIN
228-A**

**PORTAPINZA ER ATTACCO CONO MORSE
CON FILETTO - GHIERA STANDARD**

MT SHANK ER COLLET CHUCKS with THREAD - STANDARD NUT



TIPO	Art.	H	A	F	RANGE			
CM 1 A - ER 16	2915	40	32	M 6	ER 16 1÷12	4993	3698	0364
CM 2 A - ER 16	2916	42	32	M10	ER 16 1÷12	4993	3698	0364
CM 2 A - ER 20	2917	50	35	M10	ER 20 1÷15	4994	3699	0787
CM 2 A - ER 25	2918	54	42	M10	ER 25 1÷20	4995	3669	0996
CM 2 A - ER 32	3310	59	50	M10	ER 32 2÷25	4996	3670	0988
CM 3 A - ER 25	2919	53	42	M12	ER 25 1÷20	4995	3669	0996
CM 3 A - ER 32	2920	70	50	M12	ER 32 2÷25	4996	3670	0988
CM 3 A - ER 40	2921	80	63	M12	ER 40 3÷32	4997	3671	0821
CM 4 A - ER 32	2922	60	50	M16	ER 32 2÷25	4996	3670	0988
CM 4 A - ER 40	2923	81	63	M16	ER 40 3÷32	4997	3671	0821
CM 4 A - ER 50	2924	96	78	M16	ER 50 6÷36	4998	3668	4055
CM 5 A - ER 32	2902	50	50	M20	ER 32 2÷25	4996	3670	0988
CM 5 A - ER 40	2925	81	63	M20	ER 40 3÷32	4997	3671	0821
CM 5 A - ER 50	2926	91	78	M20	ER 50 6÷36	4998	3668	4055

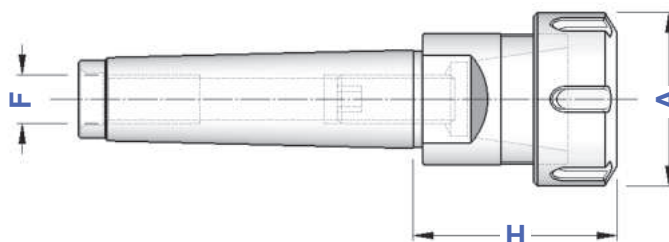

**KIT CON SERIE RIDOTTA
DI PINZE ER, MANDRINO E CHIAVE**

EQUIPMENT CASES WITH REDUCED SET OF ER COLLETS



TIPO	Art.				
KIT Rid CM 2 A - ER 25	7524	2918	7022	3669	0996: ø 4-6-8-10-12-16
KIT Rid CM 2 A - ER 32	7525	3310	7023	3670	0988: ø 4-6-8-10-12-16-20
KIT Rid CM 3 A - ER 25	7526	2919	7022	3669	0996: ø 4-6-8-10-12-16
KIT Rid CM 3 A - ER 32	7527	2920	7023	3670	0988: ø 4-6-8-10-12-16-20
KIT Rid CM 3 A - ER 40	7528	2921	7024	3671	0821: ø 4-6-8-10-12-16-20-25
KIT Rid CM 4 A - ER 32	7529	2922	7023	3670	0988: ø 4-6-8-10-12-16-20
KIT Rid CM 4 A - ER 40	7530	2923	7024	3671	0821: ø 4-6-8-10-12-16-20-25

**KIT CON SERIE COMPLETA
DI PINZE ER, MANDRINO E CHIAVE**

EQUIPMENT CASES WITH COMPLETE SET OF ER COLLETS



TIPO	Art.				
KIT CM 2 A - ER 25	7508	2918	7022	3669	0996: Ø 2 ÷ 16 (15 Pinze)
KIT CM 2 A - ER 32	7509	3310	7023	3670	0988: Ø 3 ÷ 20 (18 Pinze)
KIT CM 3 A - ER 25	7510	2919	7022	3669	0996: Ø 2 ÷ 16 (15 Pinze)
KIT CM 3 A - ER 32	7511	2920	7023	3670	0988: Ø 3 ÷ 20 (18 Pinze)
KIT CM 3 A - ER 40	7512	2921	7024	3671	0821: Ø 4 ÷ 26 (23 Pinze)
KIT CM 4 A - ER 32	7513	2922	7023	3670	0988: Ø 3 ÷ 20 (18 Pinze)
KIT CM 4 A - ER 40	7514	2923	7024	3671	0821: Ø 4 ÷ 26 (23 Pinze)

**DIN
228-B**

**PORTAPINZA ER ATTACCO CONO MORSE
CON TENONE - GHIERA STANDARD**

MT SHANK ER COLLET CHUCKS with TONQUE - STANDARD NUT



TIPO	Art.	H	A	RANGE			
CM 1 - ER 16	8627	40	32	ER 16 1÷12	4993	3698	0364
CM 2 - ER 16	8628	42	32	ER 16 1÷12	4993	3698	0364
CM 2 - ER 20	8629	50	35	ER 20 1÷15	4994	3699	0787
CM 2 - ER 25	8630	54	42	ER 25 1÷20	4995	3669	0996
CM 2 - ER 32	8631	59	50	ER 32 2÷25	4996	3670	0988
CM 3 - ER 25	8632	53	42	ER 25 1÷20	4995	3669	0996
CM 3 - ER 32	8633	70	50	ER 32 2÷25	4996	3670	0988
CM 3 - ER 40	8634	80	63	ER 40 3÷32	4997	3671	0821
CM 4 - ER 32	8635	60	50	ER 32 2÷25	4996	3670	0988
CM 4 - ER 40	8636	81	63	ER 40 3÷32	4997	3671	0821
CM 4 - ER 50	8637	96	78	ER 50 6÷36	4998	3668	4055
CM 5 - ER 32	8638	50	50	ER 32 2÷25	4996	3670	0988
CM 5 - ER 40	8639	81	63	ER 40 3÷32	4997	3671	0821
CM 5 - ER 50	8640	91	78	ER 50 6÷36	4998	3668	4055

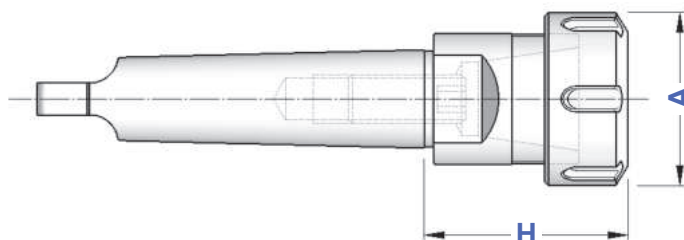

**KIT CON SERIE RIDOTTA
DI PINZE ER, MANDRINO E CHIAVE**

EQUIPMENT CASES WITH REDUCED SET OF ER COLLETS



TIPO	Art.				
KIT Rid CM 2 - ER 25	7727	8630	7022	3669	0996: Ø 4-6-8-10-12-16
KIT Rid CM 2 - ER 32	7728	8631	7023	3670	0988: Ø 4-6-8-10-12-16-20
KIT Rid CM 3 - ER 25	7729	8632	7022	3669	0996: Ø 4-6-8-10-12-16
KIT Rid CM 3 - ER 32	7730	8633	7023	3670	0988: Ø 4-6-8-10-12-16-20
KIT Rid CM 3 - ER 40	7731	8634	7024	3671	0821: Ø 4-6-8-10-12-16-20-25
KIT Rid CM 4 - ER 32	7732	8635	7023	3670	0988: Ø 4-6-8-10-12-16-20
KIT Rid CM 4 - ER 40	7733	8636	7024	3671	0821: Ø 4-6-8-10-12-16-20-25

**KIT CON SERIE COMPLETA
DI PINZE ER, MANDRINO E CHIAVE**

EQUIPMENT CASES WITH COMPLETE SET OF ER COLLETS



TIPO	Art.				
KIT CM 2 - ER 25	7734	8630	7022	3669	0996: Ø 2 ÷ 16 (15 Pinze)
KIT CM 2 - ER 32	7735	8631	7023	3670	0988: Ø 3 ÷ 20 (18 Pinze)
KIT CM 3 - ER 25	7736	8632	7022	3669	0996: Ø 2 ÷ 16 (15 Pinze)
KIT CM 3 - ER 32	7737	8633	7023	3670	0988: Ø 3 ÷ 20 (18 Pinze)
KIT CM 3 - ER 40	7738	8634	7024	3671	0821: Ø 4 ÷ 26 (23 Pinze)
KIT CM 4 - ER 32	7739	8635	7023	3670	0988: Ø 3 ÷ 20 (18 Pinze)
KIT CM 4 - ER 40	7740	8636	7024	3671	0821: Ø 4 ÷ 26 (23 Pinze)

**DIN
228-A**

PORTAFRESE WELDON CON ATTACCO CONO MORSE
MORSE TAPER END MILL HOLDERS FOR DIN 1835-B SHANKS

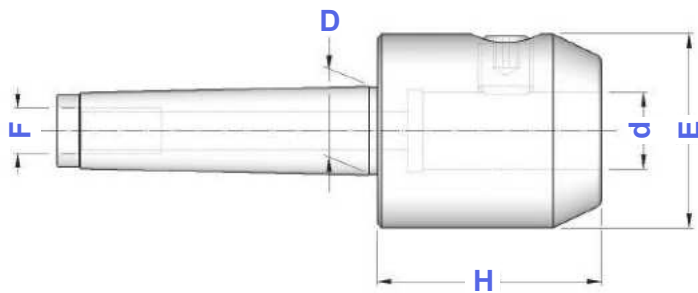

TIPO	Art.	d	H	E	D	F
CM2 A - d 6	9530	6	25	25	18,0	M10
CM2 A - d 8	9531	8	35	28	18,0	M10
CM2 A - d 10	9532	10	50	35	18,0	M10
CM2 A - d 12	9533	12	55	42	18,0	M10
CM2 A - d 14	9534	14	56	44	18,0	M10
CM2 A - d 16	9535	16	58	48	18,0	M10
CM2 A - d 18	9536	18	60	50	18,0	M10
CM2 A - d 20	9537	20	60	52	18,0	M10
CM3 A - d 6	9538	6	46	25	24,1	M12
CM3 A - d 8	9539	8	46	28	24,1	M12
CM3 A - d 10	9540	10	50	35	24,1	M12
CM3 A - d 12	9541	12	55	42	24,1	M12
CM3 A - d 14	9542	14	56	44	24,1	M12
CM3 A - d 16	9543	16	58	48	24,1	M12
CM3 A - d 18	9544	18	60	50	24,1	M12
CM3 A - d 20	9545	20	60	52	24,1	M12
CM3 A - d 25	9546	25	70	65	24,1	M12
CM4 A - d 6	9547	6	46	25	31,6	M16
CM4 A - d 8	9548	8	46	28	31,6	M16
CM4 A - d 10	9549	10	50	35	31,6	M16
CM4 A - d 12	9550	12	55	42	31,6	M16
CM4 A - d 14	9551	14	56	44	31,6	M16
CM4 A - d 16	9552	16	58	48	31,6	M16
CM4 A - d 18	9553	18	60	50	31,6	M16
CM4 A - d 20	9554	20	60	52	31,6	M16
CM4 A - d 25	9555	25	70	65	31,6	M16
CM4 A - d 32	9556	32	75	72	31,6	M16
CM4 A - d 40	9557	40	85	90	31,6	M16

**DIN 228
A ⇔ B**

TENONI PER CONO MORSE
TONQUES



TIPO	Art.	F
T.CM 1 - M 6	4079	M 6
T.CM 2 - M 10	4080	M 10
T.CM 3 - M 12	4081	M 12
T.CM 4 - M 16	4082	M 16
T.CM 5 - M 20	4083	M 20



**DIN
228-B**

**MANDRINI AUTOSERRANTI INTEGRALI CON ATTACCO CONO MORSE
ROTAZIONE DESTRA**

MORSE TAPER SHANK MONOLITHIC DRILL CHUCKS - RIGHT SPIN

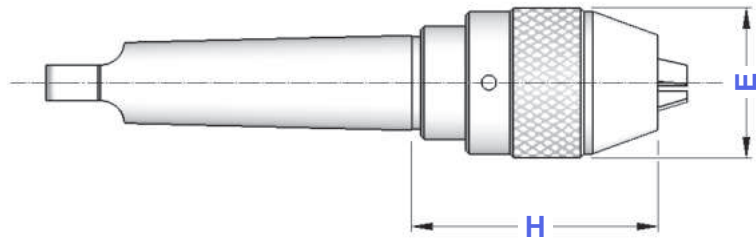

Forniti completi dell'apposita chiave
Supplied complete with suitable wrench

TIPO	Art.	RANGE	E	H	
CM 2 - DC 13	8646	0,5 ÷ 13	50	86	2370
CM 3 - DC 13	8647	0,5 ÷ 13	50	86	2370
CM 3 - DC 16	8648	3 ÷ 16	57	90	2371
CM 4 - DC 13	8649	0,5 ÷ 13	50	87	2370
CM 4 - DC 16	8650	3 ÷ 16	57	91	2371

**DIN
228-B**

**MANDRINI AUTOSERRANTI INTEGRALI CON ATTACCO CONO MORSE
ROTAZIONE DESTRA E SINISTRA**

MORSE TAPER SHANK MONOLITHIC DRILL CHUCKS - RIGHT & LEFT SPIN

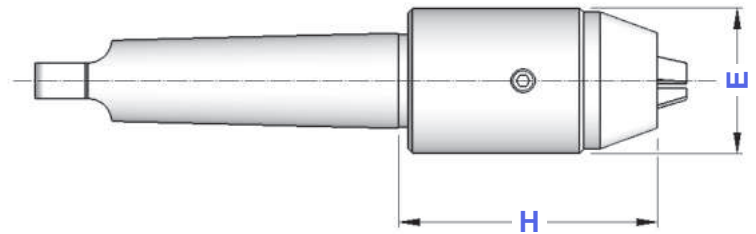

Forniti completi dell'apposita chiave
Supplied complete with suitable wrench

TIPO	Art.	RANGE	E	H	
CM 2 - DCU 13	8651	0,5 ÷ 13	50	87	2372
CM 3 - DCU 13	8652	0,5 ÷ 13	50	87	2372
CM 3 - DCU 16	8653	3 ÷ 16	50	92	
CM 4 - DCU 13	8654	0,5 ÷ 13	50	88	2372
CM 4 - DCU 16	8655	3 ÷ 16	50	94	



Le Riduzioni Cono Morse per DIN 238 si trovano a pagina 63.

MT shank adapters to DIN 238 you can find at page 63.



I Mandrini Autoserranti con attacco DIN 238 si trovano a pagina 62

DIN 238 shank Keyless Drill Chucks you can find at page 62



DIN 238
ISO 239

MANDRINI AUTOSERRANTI
KEYLESS DRILL CHUCKS

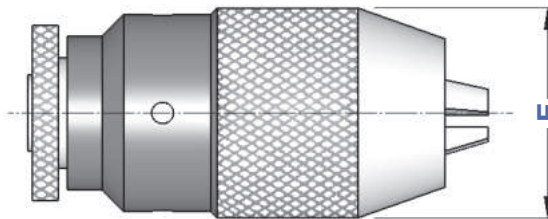
PRECISIONE
0,07



Forniti completi dell'apposita chiave
Supplied complete with suitable wrench

TIPO	Art.	RANGE	E			
B 10 - DC 6	2800	0,5 ÷ 6,5	33	9010	9018	—
B 10 - DC 8	2801	0,5 ÷ 8	38	9011	9019	2368
B 10 - DC 10	2834	0,5 ÷ 10	43	9012	9020	2369
B 12 - DC 8	2802	0,5 ÷ 8	38	9011	9019	2368
B 12 - DC 10	2803	0,5 ÷ 10	43	9012	9020	2369
B 12 - DC 13	2804	0,5 ÷ 13	50	9013	9021	2370
B 16 - DC 10	2805	0,5 ÷ 10	43	9014	9022	2369
B 16 - DC 13	2806	0,5 ÷ 13	50	9013	9021	2370
B 16 - DC 16	2807	3 ÷ 16	57	9015	9023	2371
B 18 - DC 16	2808	3 ÷ 16	57	9015	9023	2371



DIN 238
ISO 239

MANDRINI AUTOSERRANTI DI ALTA PRECISIONE
HIGH PRECISION KEYLESS DRILL CHUCKS

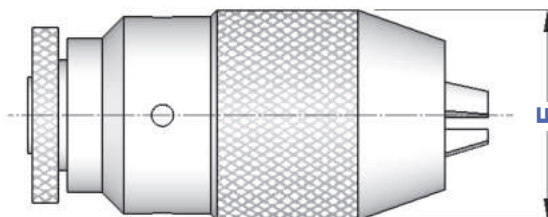
PRECISIONE
≤ 0,05



Forniti completi dell'apposita chiave
Supplied complete with suitable wrench

TIPO	Art.	RANGE	E			
B 10 - DC 8 Precision	2853	0,5 ÷ 8	38	9011	9019	2368
B 10 - DC 10 Precision	2854	0,5 ÷ 10	43	9012	9020	2369
B 12 - DC 8 Precision	2810	0,5 ÷ 8	38	9011	9019	2368
B 12 - DC 10 Precision	2856	0,5 ÷ 10	43	9012	9020	2369
B 12 - DC 13 Precision	2858	0,5 ÷ 13	50	9016	9021	2370
B 16 - DC 10 Precision	2811	0,5 ÷ 10	43	9014	9022	2369
B 16 - DC 13 Precision	2812	0,5 ÷ 13	50	9016	9021	2370
B 16 - DC 16 Precision	2813	3 ÷ 16	57	9017	9023	2371
B 18 - DC 16 Precision	2818	3 ÷ 16	57	9017	9023	2371

RIDUZIONI CM PER ATTACCO DIN 238

MORSE TAPER ADAPTERS TO DIN 238 (ISO 239)

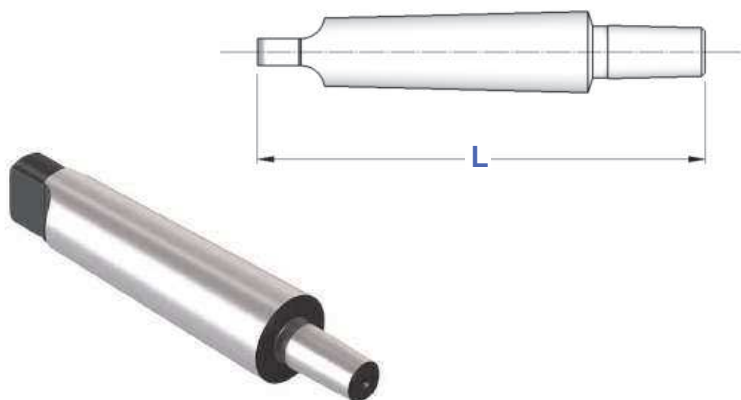

TIPO	Art.	CM	"B"	L
CM 1 - B10	4096/1-B10	1	10	83
CM 1 - B12	4096/1-B12	1	12	89
CM 1 - B16	4096/1-B16	1	16	99
CM 1 - B18	4096/1-B18	1	18	99
CM 2 - B10	4096/2-B10	2	10	105
CM 2 - B12	4096/2-B12	2	12	106
CM 2 - B16	4096/2-B16	2	16	112
CM 2 - B18	4096/2-B18	2	18	119
CM 2 - B22	4096/2-B22	2	22	130
CM 3 - B12	4096/3-B12	3	12	125
CM 3 - B16	4096/3-B16	3	16	134
CM 3 - B18	4096/3-B18	3	18	140
CM 3 - B22	4096/3-B22	3	22	147
CM 4 - B12	4096/4-B12	4	12	152
CM 4 - B16	4096/4-B16	4	16	156
CM 4 - B18	4096/4-B18	4	18	164
CM 4 - B22	4096/4-B22	4	22	176
CM 4 - B24	4096/4-B24	4	24	186
CM 5 - B16	4096/5-B16	5	16	190
CM 5 - B18	4096/5-B18	5	18	204
CM 5 - B22	4096/5-B22	5	22	213
CM 5 - B24	4096/5-B24	5	24	221

RIDUZIONI CM CON FILETTO PER ATTACCO DIN 238

MORSE TAPER ADAPTERS with THREAD TO DIN 238 (ISO 239)

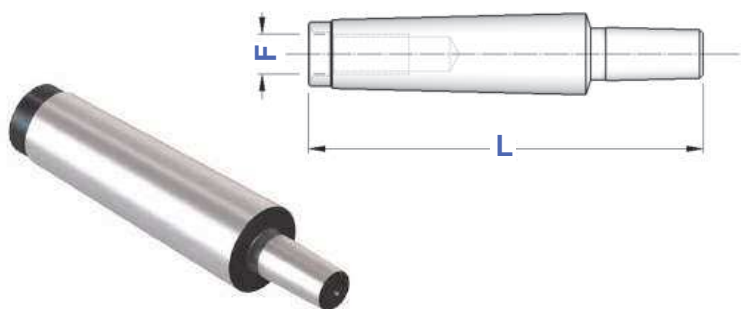

TIPO	Art.	CM	F	"B"	L
CM 2 A - B10	4024/2-B10	2	M10	10	90
CM 2 A - B12	4024/2-B12	2	M10	12	95
CM 2 A - B16	4024/2-B16	2	M10	16	101
CM 3 A - B16	4024/3-B16	3	M12	16	118
CM 4 A - B16	4024/4-B16	4	M16	16	141

RIDUZIONI CILINDRICHE PER ATTACCO DIN 238

STRAIGHT SHANK ADAPTERS TO DIN 238 (ISO 239)

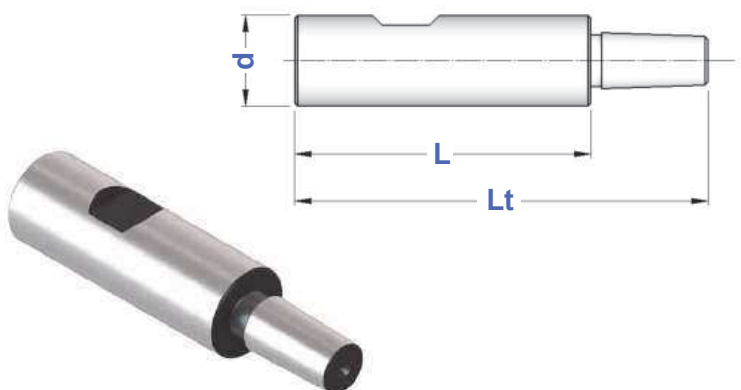

TIPO	Art.	d	"B"	L	Lt
d 8 - B10	4023/08 - B10	8	10	35	55
d 10 - B10	4023/10 - B10	10	10	50	70
d 10 - B12	4023/10 - B12	10	12	50	75
d 10 - B16	4023/10 - B16	10	16	50	82
d 12 - B16	4023/12 - B16	12	16	50	82
d 12 - B16	4023/12 - B16L	12	16	60	92
d 16 - B16	4023/16 - B16	16	16	50	81
d 16 - B16	4023/16 - B16L	16	16	70	101
d 20 - B12	4023/20 - B12	20	12	60	85
d 20 - B16	4023/20 - B16	20	16	60	92
d 20 - B18	4023/20 - B18	20	18	60	100
d 25 - B16	4023/25 - B16	25	16	75	107

**DIN
6329****PINZE CONO MORSE PER PUNTE**

MT COLLETS FOR TWIST DRILLS

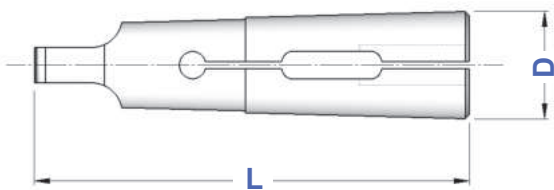

TIPO	Art.	RANGE	D	L	Einheits
CM 0 - PUNTE	5570 P	1,5 ÷ 5,5	9,2	59,5	510E
CM 1 - PUNTE	0640 P	1,5 ÷ 10,0	12,2	65,5	511E
CM 2 - PUNTE	0641 P	3,0 ÷ 15,0	18,0	80,0	514E
CM 3 - PUNTE	0642 P	8,0 ÷ 20,0	24,1	99,0	545E
CM 4 - PUNTE	0643 P	12,0 ÷ 25,0	31,6	124,0	548E
CM 5 - PUNTE	5571 P	20,0 ÷ 36,0	44,7	156,2	599E

**DIN
6328****PINZE CONO MORSE PER MASCHI**

MT COLLETS FOR MILLING CUTTERS

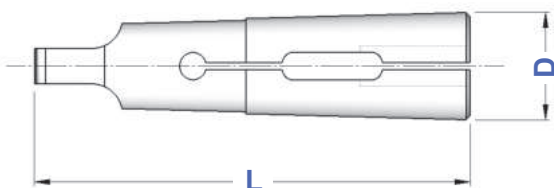

TIPO	Art.	RANGE	D	L	Einheits
CM 0 - MASCHI	5570 M	2,5 ÷ 4,5	9,2	59,5	500E
CM 1 - MASCHI	0640 M	2,5 ÷ 10,0	12,2	65,5	501E
CM 2 - MASCHI	0641 M	4,5 ÷ 14,0	18,0	80,0	504E
CM 3 - MASCHI	0642 M	8,0 ÷ 18,0	24,1	99,0	535E
CM 4 - MASCHI	0643 M	12,0 ÷ 25,0	31,6	124,0	538E
CM 5 - MASCHI	5571 M	18,0 ÷ 36,0	44,7	156,2	589E

**UNI
4702****PINZE CONO MORSE CON FILETTO**

THREADED MT COLLETS

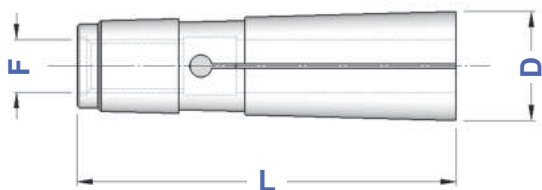

TIPO	Art.	F	RANGE	D	L	Einheits
CM 2	0752	M 10	1 ÷ 14	18,0	69,0	503E
CM 3	0712	M 12	3 ÷ 18	24,1	85,5	536E
CM 4	0865	M 16	4 ÷ 25	31,6	108,5	539E

**DIN
228-A**

**PORTA ALESATORI OSCILLANTI ATTACCO CM
CON PINZA ER**

MT FLOATING REAMER HOLDERS WITH ER COLLET



TIPO	Art.	A	E	H	F	RANGE			
CM2 RM - ER 16	3532	32	40	55	M 10	ER 16 1÷12	4993	3698	0364
CM2 RM - ER 20	3533	35	40	60	M 10	ER 20 1÷15	4994	3699	0787
CM3 RM - ER 25	3534	42	61	63	M 12	ER 25 1÷20	4995	3669	0996
CM3 RM - ER 32	3535	50	61	75	M 12	ER 32 2÷25	4996	3670	0988

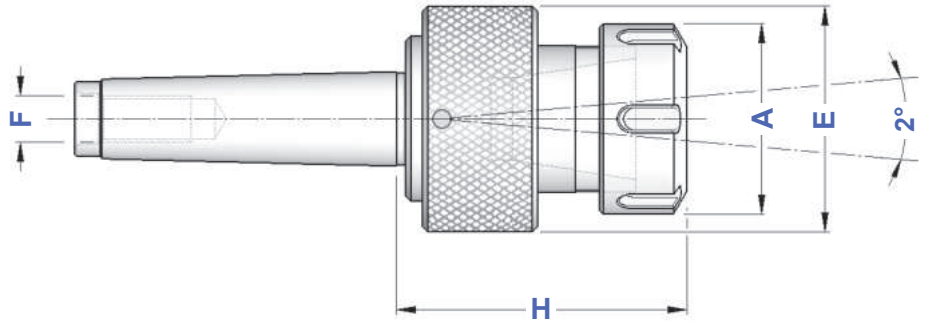

**DIN
228-B**

**PORTA ALESATORI A MANICOTTO DIN 217
ATTACCO CONO MORSE CON ESTRATTORE**

MT SHELL REAMER HOLDERS WITH EJECTOR



TIPO	Art.	D	L	Lt
PA. CM 2 - D. 10	1906	10	40	220
PA. CM 3 - D. 13	1907	13	45	250
PA. CM 3 - D. 16	1913	16	50	261
PA. CM 3 - D. 19	1914	19	56	270
PA. CM 3 - D. 22	1922	22	63	278
PA. CM 4 - D. 19	1925	19	56	298
PA. CM 4 - D. 22	1939	22	63	312
PA. CM 4 - D. 27	1944	27	71	325
PA. CM 4 - D. 32	1945	32	80	345
PA. CM 5 - D. 27	1946	27	71	359
PA. CM 5 - D. 32	1964	32	80	376
PA. CM 5 - D. 40	1966	40	90	396



**DIN
228-A**

BROCCIATORI CON ATTACCO CONO MORSE
MORSE TAPER BROACHING TOOLHOLDERS



Art.	CM	D	P	L	H	G	E	F
1668	2	8	18	69	38	10	32	M10
1669	2	12	25	69	46	16	44	M10
1670	3	16	40	85	76	21	58	M12
1671	4	16	40	109	76	21	58	M16

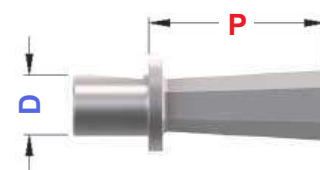
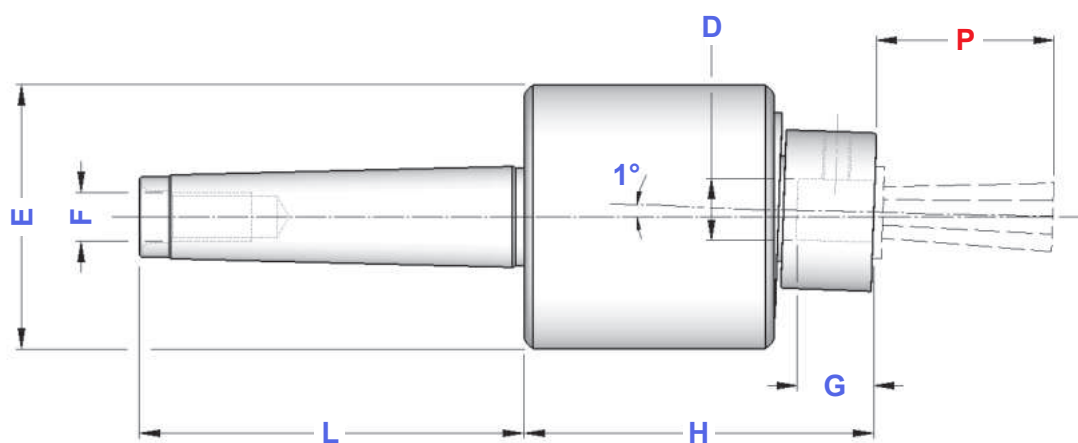

Brocche Esagonali
Hexagonal Broaches



Brocche Quadre
Square Broaches



Brocche TORX®
TORX® Broaches



Brocche TORX PLUS®
TORX PLUS® Broaches



Per il corretto funzionamento del brocciatore è importante rispettare la quota P della broccia

For the right broaching toolholder working is important to respect broach P dimension



Informazioni da pag. 346
Informations from page 346

Tenoni
Tonques



con Stelo Cilindrico
Straight shank



**DIN
228-A**

PORTAFRESE COMBINATI A CM CON FILETTO
MORSE TAPER SHANK with THREAD DIN 6358 COMBI SHELL MILL HOLDERS



TIPO	Art.	D	H	L1	L	E	F			
CM 2 A - D. 16 C	4420	16	37	27	17	32	M10	4090	0115	4985
CM 2 A - D. 22 C	4421	22	42	31	19	40	M10	4091	0116	4986
CM 3 A - D. 16 C	4292	16	37	27	17	32	M12	4090	0115	4985
CM 3 A - D. 22 C	4293	22	42	31	19	40	M12	4091	0116	4986
CM 3 A - D. 27 C	4294	27	42	33	21	48	M12	4092	0122	4987
CM 3 A - D. 32 C	4295	32	63	38	24	58	M12	4093	0125	4988
CM 4 A - D. 16 C	4296	16	55	27	17	32	M16	4090	0115	4985
CM 4 A - D. 22 C	4297	22	55	31	19	40	M16	4091	0116	4986
CM 4 A - D. 27 C	4298	27	55	33	21	48	M16	4092	0122	4987
CM 4 A - D. 32 C	4299	32	55	38	24	58	M16	4093	0125	4988
CM 5 A - D. 22 C	4422	22	75	31	19	40	M20	4091	0116	4986
CM 5 A - D. 27 C	4423	27	75	33	21	48	M20	4092	0122	4987

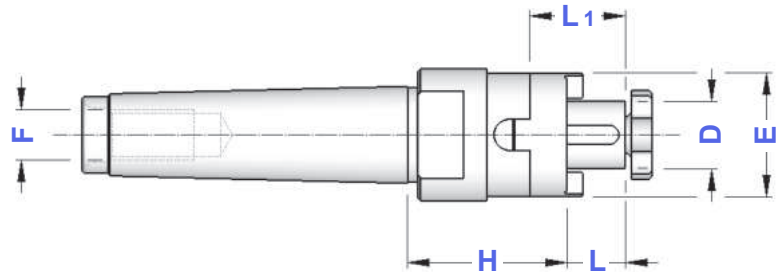

**DIN
228-B**

PORTAFRESE COMBINATI A CM CON TENONE
MORSE TAPER SHANK with TONQUE DIN 6358 COMBI SHELL MILL HOLDERS



TIPO	Art.	D	H	L1	L	E			
CM 2 - D. 16 C	8656	16	37	27	17	32	4090	0115	4985
CM 2 - D. 22 C	8657	22	42	31	19	40	4091	0116	4986
CM 3 - D. 16 C	8658	16	37	27	17	32	4090	0115	4985
CM 3 - D. 22 C	8659	22	42	31	19	40	4091	0116	4986
CM 3 - D. 27 C	8660	27	42	33	21	48	4092	0122	4987
CM 3 - D. 32 C	8661	32	63	38	24	58	4093	0125	4988
CM 4 - D. 16 C	8662	16	55	27	17	32	4090	0115	4985
CM 4 - D. 22 C	8663	22	55	31	19	40	4091	0116	4986
CM 4 - D. 27 C	8664	27	55	33	21	48	4092	0122	4987
CM 4 - D. 32 C	8665	32	55	38	24	58	4093	0125	4988
CM 5 - D. 22 C	8666	22	75	31	19	40	4091	0116	4986
CM 5 - D. 27 C	8667	27	75	33	21	48	4092	0122	4987

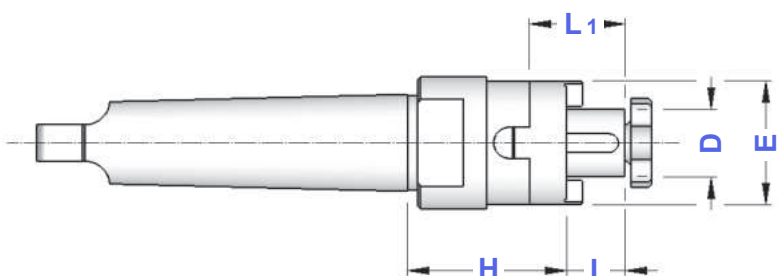

DIN 228-A

**MASCHIATORI ATTACCO CONO MORSE CON FILETTO
DOPPIA COMPENSAZIONE**

DOUBLE COMPENSATION MT TAPPING CHUCKS with THREAD

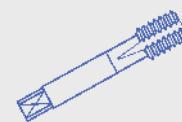

TIPO	Art.	H	E	B	F	COMPENSAZIONE	
CM 2 A - B. 0	4287	44	26	13	M10	- 6,5 + 6,5	M 1 ÷ M 10
CM 2 A - B. 1	4286	46	38	19	M10	- 7,5 + 7,5	M 3 ÷ M 12 (*M18)
CM 3 A - B. 1	4288	46	38	19	M12	- 7,5 + 7,5	M 3 ÷ M 12 (*M18)
CM 3 A - B. 2	4289	70	55	31	M12	- 12,5 + 12,5	M 6 ÷ M 20 (*M30)
CM 4 A - B. 2	4290	71	55	31	M16	- 12,5 + 12,5	M 6 ÷ M 20 (*M30)
CM 4 A - B. 3	4291	104	79	48	M16	- 20,0 + 20,0	M14 ÷ M 33 (*M48)
CM 5 A - B. 3	4426	104	79	48	M20	- 20,0 + 20,0	M14 ÷ M 33 (*M48)

* Bussole con GRANI
Adapters with SCREWS

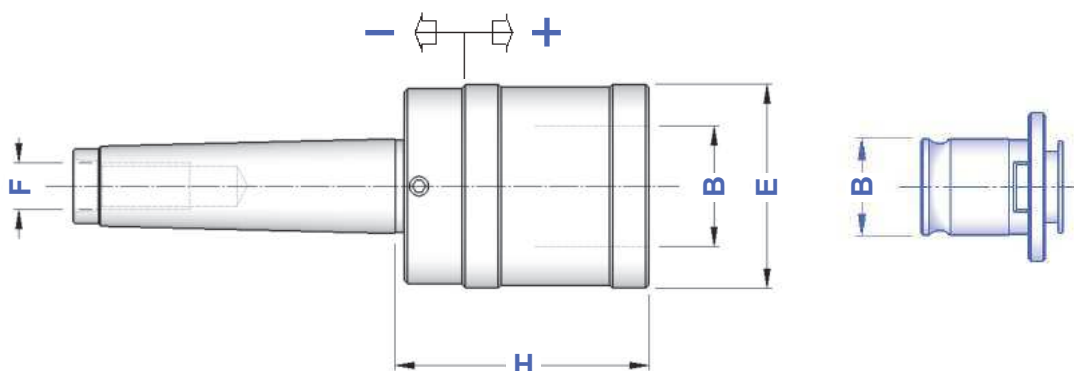

**Bussole a maschiare
da pag. 235**
Tapping Adapters
from page 235

DIN 228-B

**MASCHIATORI ATTACCO CONO MORSE CON TENONE
DOPPIA COMPENSAZIONE**

DOUBLE COMPENSATION MT TAPPING CHUCKS with TONQUE

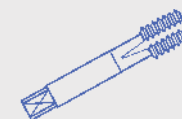

TIPO	Art.	H	E	B	COMPENSAZIONE	
CM 2 - B.0	4278	44	26	13	- 6,5 + 6,5	M 1 ÷ M 10
CM 2 - B.1	3846	46	38	19	- 7,5 + 7,5	M 3 ÷ M 12 (*M18)
CM 3 - B.1	3847	46	38	19	- 7,5 + 7,5	M 3 ÷ M 12 (*M18)
CM 3 - B.2	3848	69	55	31	- 12,5 + 12,5	M 6 ÷ M 20 (*M30)
CM 4 - B.2	3849	70	55	31	- 12,5 + 12,5	M 6 ÷ M 20 (*M30)
CM 4 - B.3	3850	104	79	48	- 20,0 + 20,0	M14 ÷ M 33 (*M48)
CM 5 - B.3	4427	104	79	48	- 20,0 + 20,0	M14 ÷ M 33 (*M48)

* Bussole con GRANI
Adapters with SCREWS

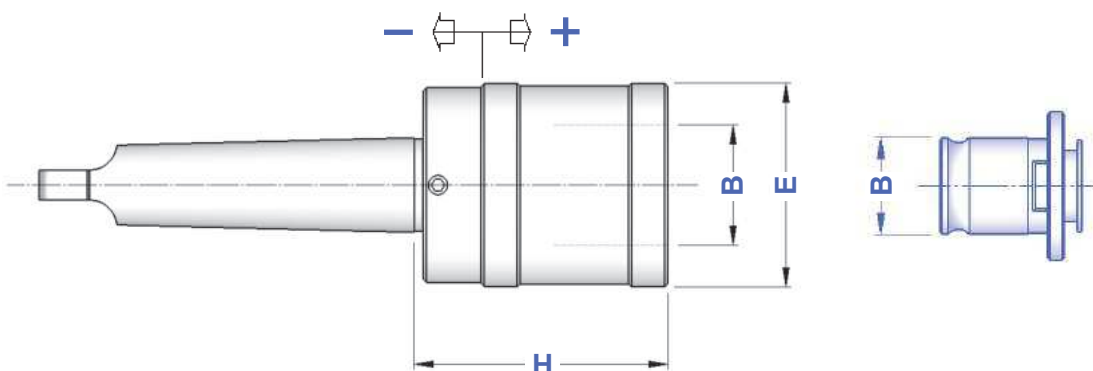

**Bussole a maschiare
da pag. 235**
Tapping Adapters
from page 235

**DIN
228-A**

**MASCHIATORI ATTACCO CONO MORSE CON FILETTO
SENZA COMPENSAZIONE**

MT TAPPING CHUCKS with THREAD WITHOUT COMPENSATION



TIPO	Art.	H	E	B	F	
CM 2 A FISSO - B. 1	4696	44	33	19	M10	M 3 ÷ M 12 (*M18)
CM 2 A FISSO - B. 2	4697	61	50	31	M10	M 6 ÷ M 20 (*M30)
CM 3 A FISSO - B. 1	4698	44	33	19	M12	M 3 ÷ M 12 (*M18)
CM 3 A FISSO - B. 2	4699	61	50	31	M12	M 6 ÷ M 20 (*M30)

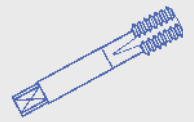

* Bussole con GRANI
Adapters with SCREWS

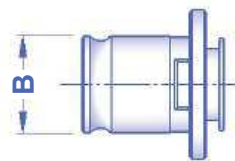
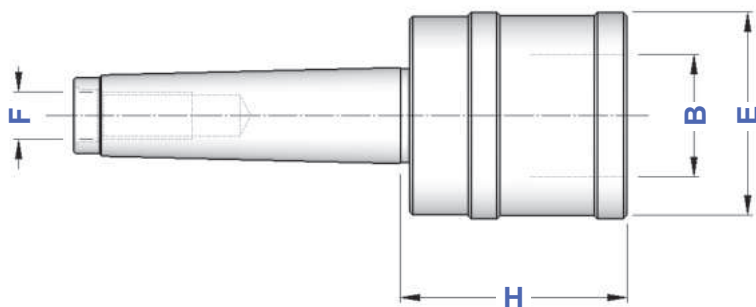

**Bussole a maschiare
da pag. 235**

Tapping Adapters
from page 235

**DIN
228-B**

**MASCHIATORI ATTACCO CONO MORSE CON TENONE
SENZA COMPENSAZIONE**

MT TAPPING CHUCKS with TONQUE WITHOUT COMPENSATION



TIPO	Art.	H	E	B	
CM 1 FISSO - B. 0	4279	39	23	13	M 1 ÷ M 10
CM 2 FISSO - B. 0	4282	40	23	13	M 1 ÷ M 10
CM 2 FISSO - B. 1	4283	45	33	19	M 3 ÷ M 12 (*M18)
CM 2 FISSO - B. 2	4027	61	50	31	M 6 ÷ M 20 (*M30)
CM 3 FISSO - B. 1	4284	45	33	19	M 3 ÷ M 12 (*M18)
CM 3 FISSO - B. 2	4285	61	50	31	M 6 ÷ M 20 (*M30)
CM 4 FISSO - B. 2	4340	61	50	31	M 6 ÷ M 20 (*M30)

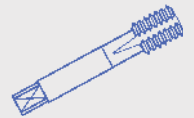

* Bussole con GRANI
Adapters with SCREWS

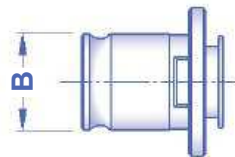
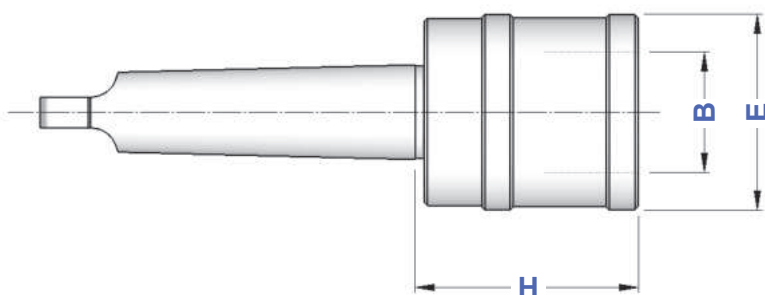

**Bussole a maschiare
da pag. 235**

Tapping Adapters
from page 235

PORTA FILIERA PER TRAPANI E MASCHIATRICI
 THREADING DIE HOLDERS FOR DRILLS AND TAPPERS

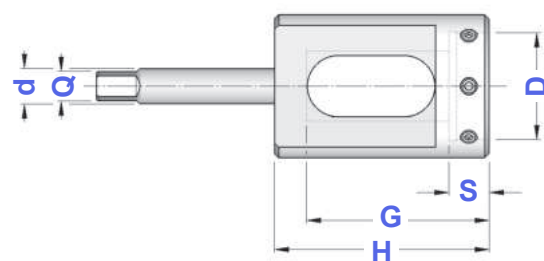
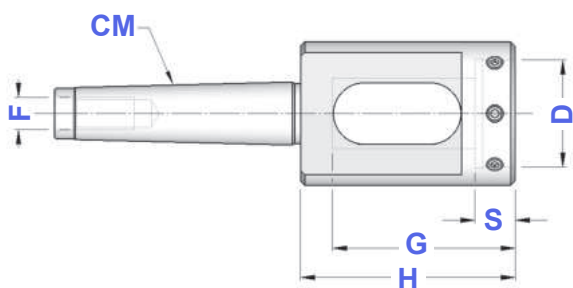

Art.	D	S	CM	F	H	G
2727	16	5	2	M 10	60	51
2728	20	7	2	M 10	60	49
2729	25	9	2	M 10	60	51
2731	30	11	2	M 10	60	51
2735	38	10	2	M 10	60	54
2767	38	14	2	M 10	60	54
2776	45	14	2	M 10	66	59
2786	45	18	2	M 10	66	59

Art.	D	S	d	Q	H	G
2540	20	7	9	7	60	49
2536	25	9	9	7	60	51
2537	30	11	10	8	60	51
2538	38	10	10	8	60	54
2544	38	14	12	9	60	54
2539	45	14	12	9	66	59
2558	45	18	14	11	66	59



Tenone CM2 - M10 art. 4080
 Tonque MT2-M10 item 4080

TP - CM

TAMPONI PULITORI PER SEDE CONO MORSE
 CLEANERS FOR MORSE TAPER SEAT



CONO MORSE	Art.
TP - CM. 1	4411
TP - CM. 2	4412
TP - CM. 3	4413
TP - CM. 4	4414
TP - CM. 5	4415
TP - CM. 6	5065

RCM.P

RIDUZIONI A CONO MORSE PASSANTI

MORSE TAPER OPEN-ENDED SLEEVES

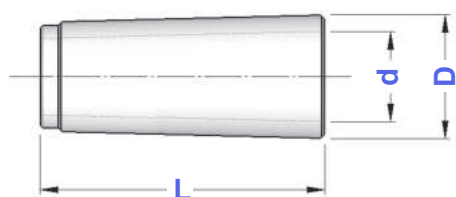

TIPO	Art.	CM		L	D	d
		Esterno	Interno			
RCM. P/2 - 1	4097/2-1	2	1	60	18,0	12,0
RCM. P/3 - 1	4097/3-1	3	1	70	24,1	12,0
RCM. P/3 - 2	4097/3-2	3	2	70	24,1	17,7
RCM. P/4 - 2	4097/4-2	4	2	70	31,6	17,7
RCM. P/4 - 3	4097/4-3	4	3	70	31,6	23,8
RCM. P/5 - 2	4097/5-2	5	2	77	44,7	17,7
RCM. P/5 - 3	4097/5-3	5	3	77	44,7	23,8
RCM. P/5 - 4	4097/5-4	5	4	77	44,7	31,2
RCM. P/6 - 3	4097/6-3	6	3	110	63,8	23,8
RCM. P/6 - 4	4097/6-4	6	4	110	63,8	31,2
RCM. P/6 - 5	4097/6-5	6	5	110	63,8	44,3

RCM.E

RIDUZIONI A CM CON ESTRATTORE

MORSE TAPER SLEEVES WITH RELEASE NUT

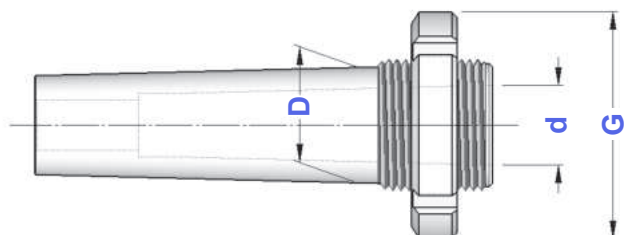

TIPO	Art.	CM		D	d	G
		Esterno	Interno			
RCM.E/2 - 1	4042/2-1	2	1	17,7	12,0	38
RCM.E/3 - 1	4042/3-1	3	1	23,8	12,0	48
RCM.E/3 - 2	4042/3-2	3	2	23,8	17,7	48
RCM.E/4 - 1	4042/4-1	4	1	31,2	12,0	57
RCM.E/4 - 2	4042/4-2	4	2	31,2	17,7	57
RCM.E/4 - 3	4042/4-3	4	3	31,2	23,8	57
RCM.E/5 - 2	4042/5-2	5	2	44,3	17,7	73
RCM.E/5 - 3	4042/5-3	5	3	44,3	23,8	73
RCM.E/5 - 4	4042/5-4	5	4	44,3	31,2	73
RCM.E/6 - 3	4042/6-3	6	3	63,3	23,8	98
RCM.E/6 - 4	4042/6-4	6	4	63,3	31,2	98
RCM.E/6 - 5	4042/6-5	6	5	63,3	44,3	98

RCM.C

RIDUZIONI A CONO MORSE MORSE TAPER ADAPTERS

DIN
2185



TIPO	Art.	CM		L	D	d
		Esterno	Interno			
RCM.C/1-0	4098/1-0	1	0	80	12,2	9,045
RCM.C/2-1	4098/2-1	2	1	92	18,0	12,065
RCM.C/3-1	4098/3-1	3	1	99	24,1	12,065
RCM.C/3-2	4098/3-2	3	2	112	24,1	17,780
RCM.C/4-1	4098/4-1	4	1	124	31,6	12,065
RCM.C/4-2	4098/4-2	4	2	124	31,6	17,780
RCM.C/4-3	4098/4-3	4	3	140	31,6	23,825
RCM.C/5-1	4098/5-1	5	1	156	44,7	12,065
RCM.C/5-2	4098/5-2	5	2	156	44,7	17,780
RCM.C/5-3	4098/5-3	5	3	156	44,7	23,825
RCM.C/5-4	4098/5-4	5	4	171	44,7	31,267
RCM.C/6-2	4098/6-2	6	2	218	63,8	17,780
RCM.C/6-3	4098/6-3	6	3	218	63,8	23,825
RCM.C/6-4	4098/6-4	6	4	218	63,8	31,267
RCM.C/6-5	4098/6-5	6	5	218	63,8	44,399

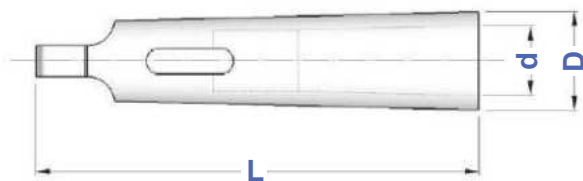

RCM.L

RIDUZIONI A CM PROLUNGATE EXTENDED MORSE TAPER ADAPTERS

DIN
2187



TIPO	Art.	CM		L	Lt	D	d
		Esterno	Interno				
RCM.L/1-1	4099/1-1	1	1	83,0	145	20	12,065
RCM.L/1-2	4099/1-2	1	2	98,0	160	30	17,780
RCM.L/2-1	4099/2-1	2	1	85,0	160	20	12,065
RCM.L/2-2	4099/2-2	2	2	100,0	175	30	17,780
RCM.L/2-3	4099/2-3	2	3	121,0	196	36	23,825
RCM.L/2-4	4099/2-4	2	4	145,0	220	48	31,267
RCM.L/3-1	4099/3-1	3	1	81,0	175	20	12,065
RCM.L/3-2	4099/3-2	3	2	100,0	194	30	17,780
RCM.L/3-3	4099/3-3	3	3	112,0	215	36	23,825
RCM.L/3-4	4099/3-4	3	4	146,0	240	48	31,267
RCM.L/4-1	4099/4-1	4	1	82,5	200	20	12,065
RCM.L/4-2	4099/4-2	4	2	97,5	215	30	17,780
RCM.L/4-3	4099/4-3	4	3	122,5	240	36	23,825
RCM.L/4-4	4099/4-4	4	4	147,5	265	48	31,267
RCM.L/4-5	4099/4-5	4	5	182,5	300	63	44,399
RCM.L/5-1	4099/5-1	5	1	82,5	232	20	12,065
RCM.L/5-2	4099/5-2	5	2	97,5	247	30	17,780
RCM.L/5-3	4099/5-3	5	3	118,5	268	36	23,825
RCM.L/5-4	4099/5-4	5	4	150,5	300	48	31,267
RCM.L/5-5	4099/5-5	5	5	185,5	335	63	44,399
RCM.L/5-6	4099/5-6	5	6	247,0	396	82	63,348
RCM.L/6-3	4099/6-3	6	3	120,0	330	36	23,825
RCM.L/6-4	4099/6-4	6	4	180,0	355	48	31,267
RCM.L/6-5	4099/6-5	6	5	180,0	390	63	44,399
RCM.L/6-6	4099/6-6	6	6	241,0	451	82	63,348

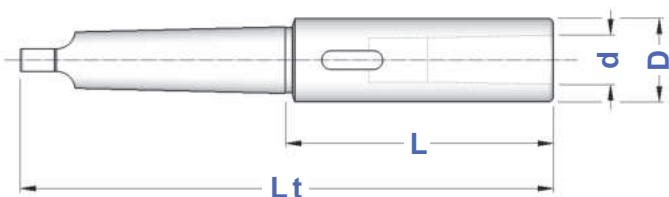

RXL

PROLUNGHE A CM EXTRALUNGHE
EXTRA-EXTENDED MORSE TAPER EXTENSIONS



TIPO	Art.	CM		L	Lt	D	d
		Esterno	Interno				
RXL 1 - 1/200	8800	1	1	138,0	200	20	12,065
RXL 1 - 1/250	8801	1	1	188,0	250	20	12,065
RXL 1 - 1/300	8802	1	1	238,0	300	20	12,065
RXL 1 - 1/350	8803	1	1	288,0	350	20	12,065
RXL 1 - 1/400	8804	1	1	338,0	400	20	12,065
RXL 1 - 1/450	8805	1	1	388,0	450	20	12,065
RXL 1 - 1/500	8806	1	1	438,0	500	20	12,065
RXL 2 - 2/200	8807	2	2	125,0	200	25	17,780
RXL 2 - 2/250	8808	2	2	175,0	250	25	17,780
RXL 2 - 2/300	8809	2	2	225,0	300	25	17,780
RXL 2 - 2/350	8810	2	2	275,0	350	25	17,780
RXL 2 - 2/400	8811	2	2	325,0	400	25	17,780
RXL 2 - 2/450	8812	2	2	375,0	450	25	17,780
RXL 2 - 2/500	8813	2	2	425,0	500	25	17,780
RXL 2 - 2/600	8814	2	2	525,0	600	25	17,780
RXL 3 - 3/250	8815	3	3	156,0	250	32	23,825
RXL 3 - 3/300	8816	3	3	206,0	300	32	23,825
RXL 3 - 3/350	8817	3	3	256,0	350	32	23,825
RXL 3 - 3/400	8818	3	3	306,0	400	32	23,825
RXL 3 - 3/450	8819	3	3	356,0	450	32	23,825
RXL 3 - 3/500	8820	3	3	405,0	500	32	23,825
RXL 3 - 3/600	8821	3	3	506,0	600	32	23,825
RXL 4 - 4/300	8822	4	4	182,5	300	40	31,267
RXL 4 - 4/350	8823	4	4	232,5	350	40	31,267
RXL 4 - 4/400	8824	4	4	282,5	400	40	31,267
RXL 4 - 4/450	8825	4	4	332,5	450	40	31,267
RXL 4 - 4/500	8826	4	4	382,5	500	40	31,267
RXL 4 - 4/600	8827	4	4	482,5	600	40	31,267

DIN 317

CACCIACONI
CONE EJECTORS

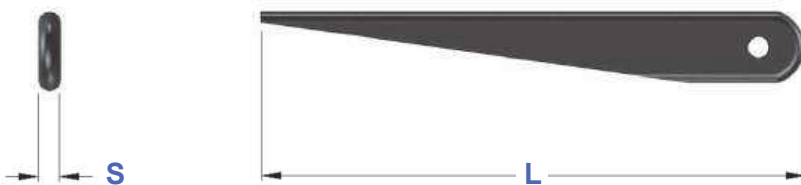

TIPO	Art.	L	S
BC.CM 0	5235	90	4
BC.CM 1	5236	140	5
BC.CM 2			
BC.CM 3	5237	190	7
BC.CM 4	5238	225	10
BC.CM 5	5239	265	15
BC.CM 6			

VERSIONE UNIVERSALE
UNIVERSAL VERSION

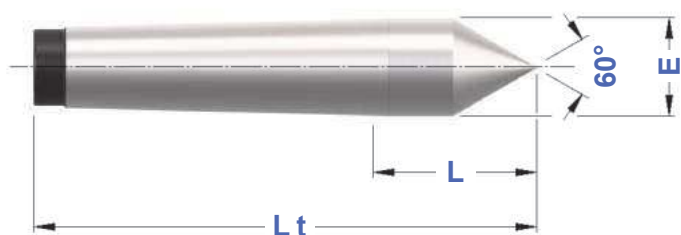

TIPO	Art.	L
BU.CM 1 - 2 - 3	5288	317
BU.CM 4 - 5 - 6	5289	380

DIN 806**CONTROPUNTE ATTACCO CM IN ACCIAIO**
STEEL MORSE TAPER SHANK TAILSTOCKS**CP.A**

TIPO	Art.	E	L	Lt
CP. A - CM 1	4335	12,2	26,5	80
CP. A - CM 2	4336	18,0	36,0	100
CP. A - CM 3	4337	24,1	44,0	125
CP. A - CM 4	4338	31,6	57,5	160
CP. A - CM 5	4339	44,7	70,5	200
CP. A - CM 6	8487	63,8	88,0	270

DIN 806**CONTROPUNTE ATTACCO CM CON METALLO DURO**
MORSE TAPER SHANK TAILSTOCKS WITH SOLID CARBIDE**CP.W**

TIPO	Art.	D	E	L	Lt
CP. W - CM 1	3957	7	12,2	26,5	80
CP. W - CM 2	4341	7	18,0	36,0	100
CP. W - CM 3	4342	11	24,1	44,0	125
CP. W - CM 4	4343	14	31,6	57,5	160
CP. W - CM 5	4344	18	44,7	70,5	200

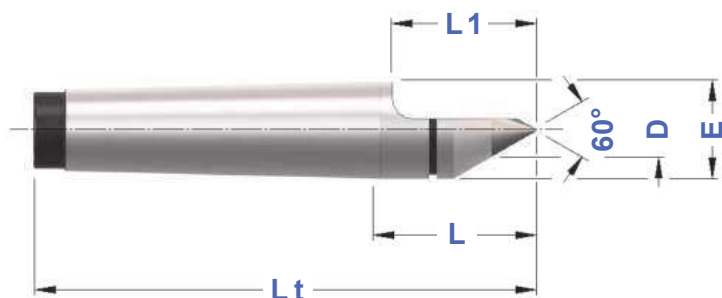
DIN 806**CONTROPUNTE PER RETTIFICA CON METALLO DURO**
MT SHANK TAILSTOCKS FOR GRINDING WITH SOLID CARBIDE**CP.R**

TIPO	Art.	D	E	L	L1	Lt
CP. R - CM 1	3959	7	12,2	26,5	22	80
CP. R - CM 2	4345	7	18,0	36,0	30	100
CP. R - CM 3	4346	11	24,1	44,0	38	125
CP. R - CM 4	4347	14	31,6	57,5	50	160
CP. R - CM 5	4348	18	44,7	70,5	73	200

DIN 807

**CONTROPUNTE ATTACCO CM IN ACCIAIO
CON ESTRATTORE**
STEEL MT SHANK TAILSTOCKS WITH RELEASE NUT

CP.E



TIPO	Art.	E	L	Lt
CP. E - CM 2	5381	18,0	36,0	100
CP. E - CM 3	5382	24,1	44,0	125
CP. E - CM 4	5383	31,6	57,5	160
CP. E - CM 5	5384	44,7	70,5	200
CP. E - CM 6	8490	63,8	88,0	270

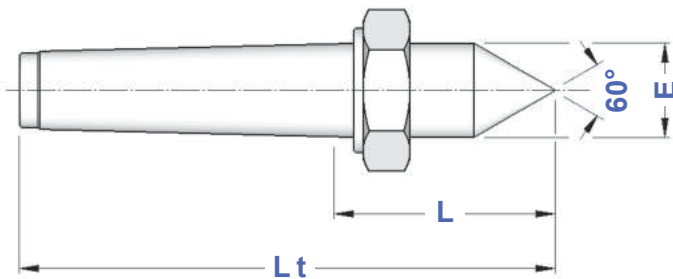

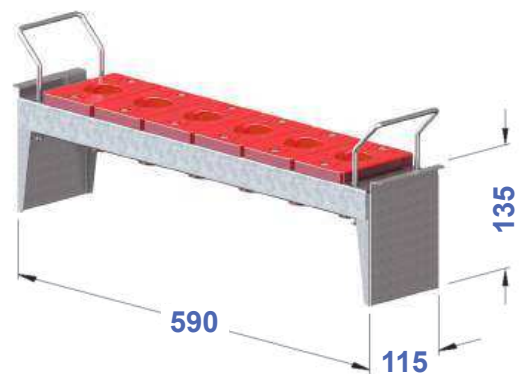
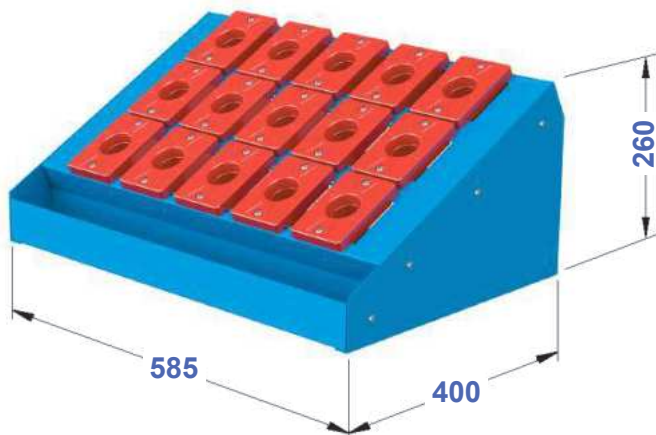

MAGAZZINI per CONO MORSE
MORSE TAPER SHANK STORAGE

UNITA' DA BANCO per CONO MORSE
BENCH UNITIES for MORSE TAPER SHANK



Forniti completi di boccole rosse
Supplied complete of
red tool holder bushings

Fornite complete di boccole rosse
Supplied complete of
red tool holder bushings

TIPO	Art.	N° SEDI		
MAG. CM 2	9468	15	9448	0033
MAG. CM 3	9469	15	9449	
MAG. CM 4	3696	15	4400	
MAG. CM 5	3702	15	4418	

TIPO	Art.	N° SEDI	
UNITÀ CM 2	9458	6	9448
UNITÀ CM 3	9459	6	9449
UNITÀ CM 4	4329	6	4400
UNITÀ CM 5	4330	6	4418

CR

CONTROPUNTE ROTANTI CON ATTACCO CONO MORSE

MORSE TAPER SHANK REVOLVING TAILSTOCKS



CARATTERISTICHE

- con un cuscinetto a sfere radiale ed un cuscinetto a sfere assiale.
- non necessita di manutenzione, lubrificata con grasso permanente.

CHARACTERISTICS

- with one radial ball bearing and one axial ball bearing.
- maintenance not required, it is lubricated with permanent grease.



CARATTERISTICHE

- con tre cuscinetti a sfera radiali.
- non necessita di manutenzione, lubrificata con grasso permanente.
- punta in acciaio per utensili legato al Cromo.
- alta concentricità.

CHARACTERISTICS

- with three radial ball bearings.
- maintenance not required, it is lubricated with permanent grease.
- tip in chromium-alloyed tool steel.
- high concentricity.



CARATTERISTICHE

- con un cuscinetto obliquo a doppia corona di sfere ed un cuscinetto a sfere assiale ad alta resistenza.
- non necessita di manutenzione, lubrificata con grasso permanente.
- punta in acciaio per utensili legato al Cromo ad elevata resistenza all'usura.
- alta concentricità.
- maggiore tenuta contro sporco e liquido refrigerante.

CHARACTERISTICS

- with one oblique bearing double-crown ball and one axial high strength ball bearing.
- maintenance not required, it is lubricated with permanent grease.
- tip in chromium-alloyed tool steel with high wear resistance.
- high concentricity.
- greater resistance against dirt and coolant.

TIPO STANDARD

STANDARD TYPE

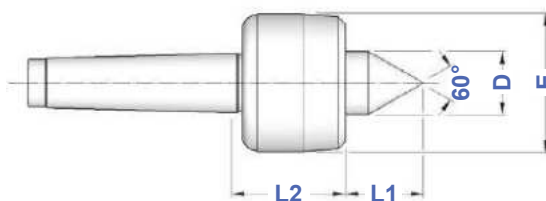

TIPO	Art.	E	D	L1	L2	Rpm Max	Carico Assiale Max (N)
CR.A - CM 1	4349	36	15	17,0	43,5	7000	100
CR.A - CM 2	4350	45	20	24,0	41,0	7000	200
CR.A - CM 3	4351	60	25	31,0	48,5	5000	500
CR.A - CM 4	4352	70	32	41,0	61,5	3800	800
CR.A - CM 5	4353	90	40	50,5	78,5	3000	2000
CR.A - CM 6	8330	105	50	57,5	94,5	2600	3500

TIPO PRECISO PER CARICHI MEDI

ACCURATE TYPE FOR MEDIUM LOADS

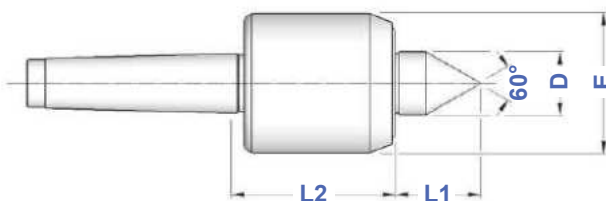

TIPO	Art.	E	D	L1	L2	Rpm Max	Carico Assiale Max (N)
CR.B - CM 1	8537	28	12	17	40,5	6500	250
CR.B - CM 2	8538	35	13	18	47,0	5500	800
CR.B - CM 3	8539	45	20	26	57,0	5000	1500
CR.B - CM 4	8540	60	24	34	70,5	4000	4000

TIPO PRECISO PER CARICHI ELEVATI

ACCURATE TYPE FOR HIGH LOADS

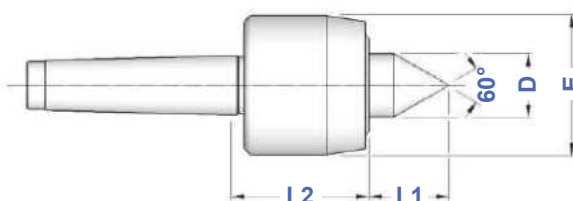

TIPO	Art.	E	D	L1	L2	Rpm Max	Carico Assiale Max (N)
CR.C - CM 2	8542	45	20	25	49	5000	1500
CR.C - CM 3	8543	45	20	25	52	5000	2000
CR.C - CM 4	8544	60	24	32	62	4300	6000
CR.C - CM 5	8545	78	32	46	69	3200	18000
CR.C - CM 6	8546	110	52	62	90	2000	45000

CR COPY

CONTROPUNTE ROTANTI PROLUNGATE COPY CON ATTACCO CM

MORSE TAPER SHANK COPY REVOLVING TAILSTOCKS



CARATTERISTICHE

- con un cuscinetto a sfere radiale ed un cuscinetto a sfere assiale.
- non necessita di manutenzione, lubrificata con grasso permanente.

CHARACTERISTICS

- with one radial ball bearing and one axial ball bearing.
- maintenance not required, it is lubricated with permanent grease.



CARATTERISTICHE

- con tre cuscinetti a sfera radiali.
- non necessita di manutenzione, lubrificata con grasso permanente.
- punta in acciaio per utensili legato al Cromo.
- alta concentricità.

CHARACTERISTICS

- with three radial ball bearings.
- maintenance not required, it is lubricated with permanent grease.
- tip in chromium-alloyed tool steel.
- high concentricity.



CARATTERISTICHE

- con un cuscinetto obliquo a doppia corona di sfere ed un cuscinetto a sfere assiale ad alta resistenza.
- non necessita di manutenzione, lubrificata con grasso permanente.
- punta in acciaio per utensili legato al Cromo ad elevata resistenza all'usura.
- alta concentricità.
- maggiore tenuta contro sporco e liquido refrigerante.

CHARACTERISTICS

- with one oblique bearing double-crown ball and one axial high strength ball bearing.
- maintenance not required, it is lubricated with permanent grease.
- tip in chromium-alloyed tool steel with high wear resistance.
- high concentricity.
- greater resistance against dirt and coolant.

TIPO STANDARD PROLUNGATO COPY

STANDARD EXTENDED COPY TYPE

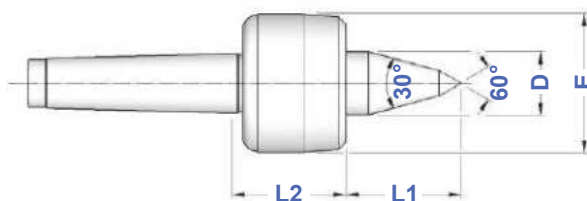

TIPO	Art.	E	D	L1	L2	Rpm Max	Carico Assiale Max (N)
CR.D - CM 2	5392	45	20	34	41,0	7000	140
CR.D - CM 3	5393	60	25	47	48,5	5000	400
CR.D - CM 4	5394	70	32	53	61,5	3800	500
CR.D - CM 5	5395	90	40	65	78,5	3000	1200
CR.D - CM 6	8331	105	50	78	94,5	2600	2500

TIPO PRECISO PROLUNGATO COPY PER CARICHI MEDI

ACCURATE FOR MEDIUM LOADS EXTENDED COPY TYPE

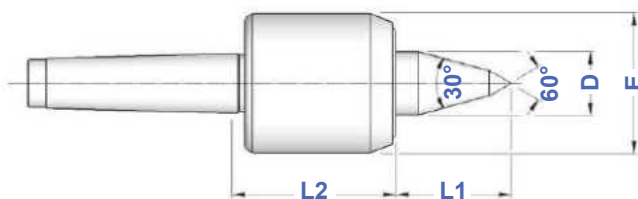

TIPO	Art.	E	D	L1	L2	Rpm Max	Carico Assiale Max (N)
CR.E - CM 2	8548	45	20	36	57	5000	1000
CR.E - CM 3	8549	45	20	36	57	5000	1500
CR.E - CM 4	8550	60	24	46	70	4000	4000

TIPO PRECISO PROLUNGATO COPY PER CARICHI ELEVATI

ACCURATE FOR HIGH LOADS EXTENDED COPY TYPE

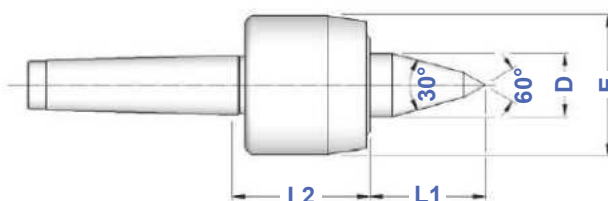





TIPO	Art.	E	D	L1	L2	Rpm Max	Carico Assiale Max (N)
CR.F - CM 2	8552	45	20	36	49	5000	1000
CR.F - CM 3	8553	45	20	36	52	5000	1500
CR.F - CM 4	8554	60	24	46	59	4300	4000
CR.F - CM 5	8555	78	32	60	68	3200	12000
CR.F - CM 6	8556	110	52	84	90	2000	25000

RAG

PORTAPINZA ER - ATTACCO TIPO FAMUP RAG

FAMUP RAG TYPE SHANK ER COLLET CHUCKS





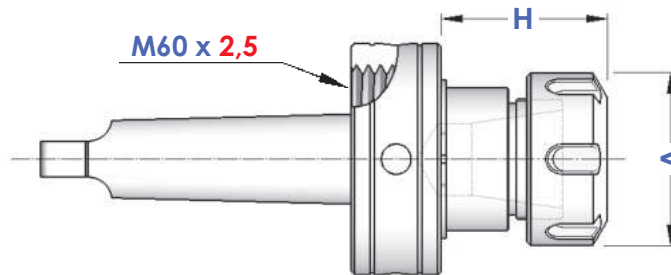

TIPO	Art.	H	A	RANGE				
CM4 FAMUP RAG - ER 32	4277	52	50	ER32 2÷25	2420	4996	3670	0988
CM4 FAMUP RAG - ER 40	4280	55	63	ER40 3÷32	2420	4997	3671	0821



KIT CON SERIE RIDOTTA DI PINZE ER, MANDRINO E CHIAVE

EQUIPMENT CASES WITH REDUCED SET OF ER COLLETS







TIPO	Art.				
KIT Rid CM 4 RAG - ER 32	7531	4277	7023	3670	0988: $\varnothing 4-6-8-10-12-16-20$
KIT Rid CM 4 RAG - ER 40	7721	4280	7024	3671	0821: $\varnothing 4-6-8-10-12-16-20-25$

KIT CON SERIE COMPLETA DI PINZE ER, MANDRINO E CHIAVE

EQUIPMENT CASES WITH COMPLETE SET OF ER COLLETS







TIPO	Art.				
KIT CM 4 RAG - ER 32	7515	4277	7023	3670	0988: $\varnothing 3 \div 20$ (18 Pinze)
KIT CM 4 RAG - ER 40	7722	4280	7024	3671	0821: $\varnothing 4 \div 26$ (23 Pinze)

RAG

PORTAFRESE FISSO - ATTACCO TIPO FAMUP RAG

FAMUP RAG TYPE SHANK SHELL MILL HOLDERS



TIPO	Art.	D	H	L	E				
CM 4 RAG - D. 16 FISSO	2414	16	27	17	32	2420	0041	4985	4562
CM 4 RAG - D. 22 FISSO	2415	22	27	19	40	2420	0044	4986	4563
CM 4 RAG - D. 27 FISSO	2416	27	27	21	48	2420	0045	4987	4564
CM 4 RAG - D. 32 FISSO	2417	32	27	24	58	2420	0047	4988	4565

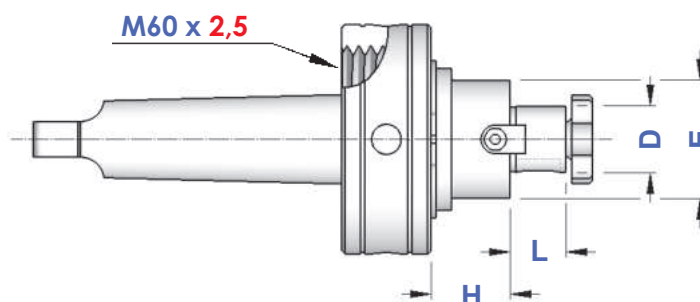





BIMAK

PORTAPINZA ER - ATTACCO TIPO BIMAK

BIMAK TYPE SHANK ER COLLET CHUCKS





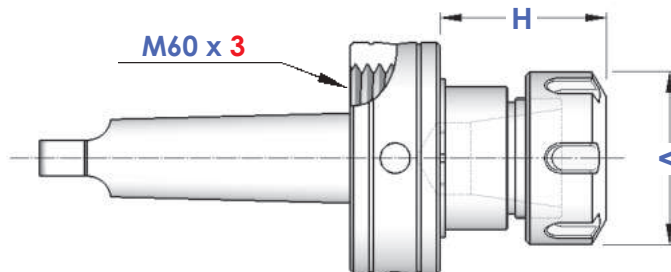

TIPO	Art.	H	A	RANGE				
CM 4 BIMAK - ER 32	4281	52	50	ER32 2÷25	2423	4996	3670	0988
CM 4 BIMAK - ER 40	4354	55	63	ER40 3÷32	2423	4997	3671	0821



KIT CON SERIE RIDOTTA DI PINZE ER, MANDRINO E CHIAVE

EQUIPMENT CASES WITH REDUCED SET OF ER COLLETS







TIPO	Art.				
KIT Rid CM 4 BIMAK - ER 32	7723	4281	7023	3670	0988: $\varnothing 4-6-8-10-12-16-20$
KIT Rid CM 4 BIMAK - ER 40	7724	4354	7024	3671	0821: $\varnothing 4-6-8-10-12-16-20-25$

KIT CON SERIE COMPLETA DI PINZE ER, MANDRINO E CHIAVE

EQUIPMENT CASES WITH COMPLETE SET OF ER COLLETS







TIPO	Art.				
KIT CM 4 BIMAK - ER 32	7725	4281	7023	3670	0988: $\varnothing 3 \div 20$ (18 Pinze)
KIT CM 4 BIMAK - ER 40	7726	4354	7024	3671	0821: $\varnothing 4 \div 26$ (23 Pinze)

BIMAK

PORTAFRESE FISSO - ATTACCO TIPO BIMAK

BIMAK TYPE SHANK SHELL MILL HOLDERS



TIPO	Art.	D	H	L	E				
CM 4 BIMAK - D. 16 FISSO	2260	16	27	17	32	2423	0041	4985	4562
CM 4 BIMAK - D. 22 FISSO	2261	22	27	19	40	2423	0044	4986	4563
CM 4 BIMAK - D. 27 FISSO	2262	27	27	21	48	2423	0045	4987	4564
CM 4 BIMAK - D. 32 FISSO	2263	32	27	24	58	2423	0047	4988	4565

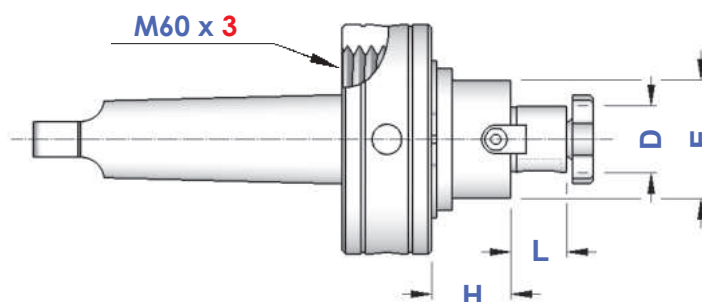

**BRIDGEPORT
R8**

PINZA BRIDGEPORT R8
BRIDGEPORT R8 COLLET

Einheits



TIPO	Art.	RANGE	A	B	L	α	M	
PINZA R8	0716	2,0 ÷ 22	24,12	32	106	8° 35'	7/16 - 20"	369E

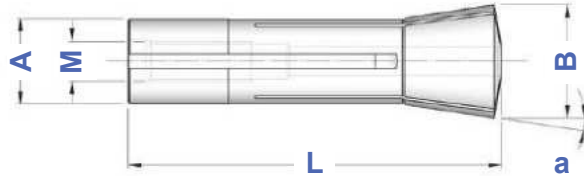

**BRIDGEPORT
R8**

PORTAPINZA ER
ER COLLET CHUCKS



TIPO	Art.	H	A	RANGE			
PORTAPINZA R8 - ER 32	2973	40	50	ER 32 2÷25	4996	3670	0988
PORTAPINZA R8 - ER 40	2974	73	63	ER 40 3÷32	4997	3671	0821

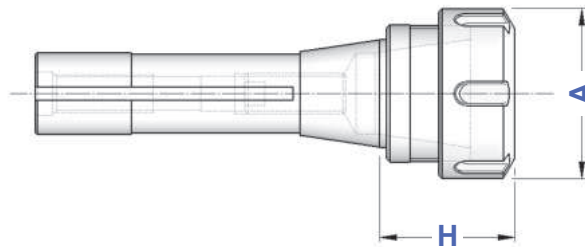

KIT CON SERIE RIDOTTA
DI PINZE ER, MANDRINO E CHIAVE
EQUIPMENT CASES WITH REDUCED SET OF ER COLLETS



TIPO	Art.				
KIT Rid R 8 - ER 32	7668	2973	7023	3670	0988: ∅ 4-6-8-10-12-16-20



KIT CON SERIE COMPLETA
DI PINZE ER, MANDRINO E CHIAVE
EQUIPMENT CASES WITH COMPLETE SET OF ER COLLETS



TIPO	Art.				
KIT R 8 - ER 32	7669	2973	7023	3670	0988: ∅ 3 ÷ 20 (18 Pinze)



**BRIDGEPORT
R8**

MANDRINI AUTOSERRANTI INTEGRALI - ROTAZIONE DESTRA
MONOLITHIC DRILL CHUCKS - RIGHT SPIN



TIPO	Art.	RANGE	E	H	
R 8 - DC 13	3000	0,5 ÷ 13	50	81	2370



Forniti completi dell'apposita chiave
Supplied complete with suitable wrench



**BRIDGEPORT
R8**

ATTACCHI PER MANDRINI AUTOSERRANTI
SHANKS FOR DRILL CHUCKS DIN 238 / ISO 239 TYPE



TIPO	Art.	D	H	DIN 238
R 8 - B 16	1089	15,733	10	B 16

DIN 238

**BRIDGEPORT
R8**

PORTAFRESE FISSI
FACE MILL HOLDERS



TIPO	Art.	D	H	L	E		
PORTAFRESA R8 - D. 16	2978	16	19	17	38	4985	4562
PORTAFRESA R8 - D. 22	2979	22	23	19	46	4986	4563
PORTAFRESA R8 - D. 27	2980	27	23	21	48	4987	4564
PORTAFRESA R8 - D. 32	2981	32	24	24	58	4988	4565

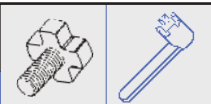

**BRIDGEPORT
R8**

RIDUZIONI A CONO MORSE
ADAPTERS TO MORSE TAPER



TIPO	Art.	Lt	CM
RIDUZIONE R8 - CM 1 PUNTE	2975	114	1
RIDUZIONE R8 - CM 2 PUNTE	2976	127	2
RIDUZIONE R8 - CM 3 PUNTE	2977	153	3
RIDUZIONE R8 - CM 4 PUNTE	2993	240	4

CM

CARATTERISTICHE TECNICHE CONI DIN 2080

NT TAPERS DIN 2080 STANDARD FEATURES

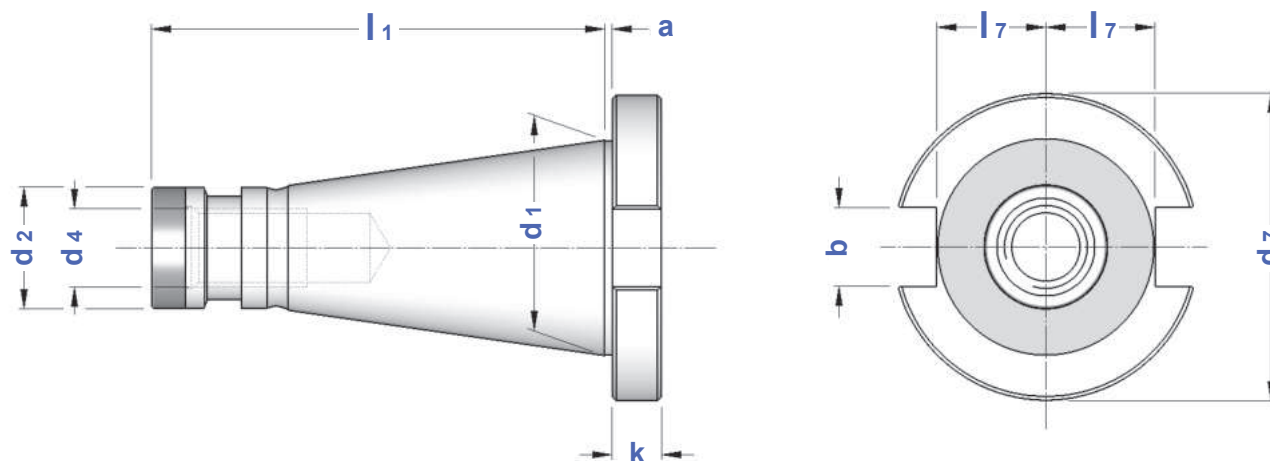

CONO	a	b	d1	d2	d4	d7	k	l1	l7	PRECISIONE
ISO 30 - DIN 2080	1,6	16,1	31,75	17,4	M 12	50	8	68,4	16,2	
ISO 40 - DIN 2080	1,6	16,1	44,45	25,3	M 16	63	10	93,4	22,5	
ISO 50 - DIN 2080	3,2	25,7	69,85	39,6	M 24	97,5	12	126,8	35,3	



OTT

CODOLI OTT ADATTATORI a DIN 2080

OTT PULL STUDS ADAPTERS to DIN 2080

TIPO	Art.	M	M1	D	D1	L	L1	L2
OTT M16 - TC 40	3487	M16	M16	25,3	17	53	25	13,6
OTT M16 - BT 40	3466	M16	M16	25,3	17	56	28	16,6
OTT M24 - CONO 50	0087	M24	M24	39,6	25	65	25	13

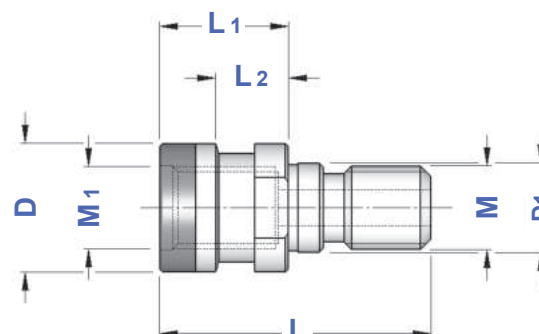
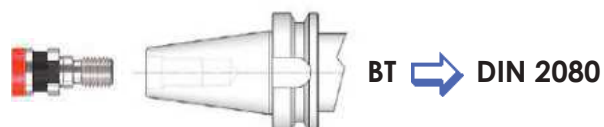

INDICE DELL' ATTACCO DIN 2080

INDEX OF NT SHANK DIN 2080

**attacchi per
AUTOSERRANTI**SHANKS for
DIN 238 DRILL CHUCKS
pag. 84**AUTOSERRANTI INTEGRALI**

MONOLITHIC DRILL CHUCKS

pag. 84

**PORTAPINZA ER
ghiera MINI**ER MINI NUT
COLLET CHUCKS
pag. 85**PORTAPINZA ER
ghiera STANDARD**ER STANDARD NUT
COLLET CHUCKS
pag. 86 - 87**mandrini per
PINZE EOC**DIN 6388 EOC
COLLET CHUCKS
pag. 88**FORTE SERRAGGIO**

HIGH GRIP CHUCKS

pag. 89

**PORTAFRESE WELDON**END MILL HOLDERS
for DIN 1835-B SHANK

pag. 90 - 91

**riduzioni a CONO MORSE
per PUNTE e per FRESE**MT ADAPTERS for TWIST DRILLS and
for MILLING CUTTERS
pag. 92 - 93**PORTAFRESE FISSI**

FACE MILL HOLDERS

pag. 94

**PORTAFRESE COMBINATI**

COMBI SHELL MILL HOLDERS

pag. 95

**P/FRESE con CHIAVETTA
di TRASCINAMENTO**MILLING CUTTER HOLDERS
with FEATHER KEY
pag. 95**PORTAFRESE ad INSERTI**FACE MILL HOLDERS for
FACE MILLING CUTTERS

pag. 96

**MASCHIATORI**

TAPPING CHUCKS

pag. 97

**BARRE
a STELO TENERO**

BLANK BARS

pag. 98

**riduzioni da ISO a ISO**

ISO to ISO REDUCTIONS

pag. 98

**riduzioni passanti
da ISO a ISO**

NT to NT OPEN-ENDED REDUCTIONS

pag. 98



DIN 2080

ATTACCHI PER MANDRINI AUTOSERRANTI

SHANKS FOR DRILL CHUCKS DIN 238 / ISO 239 TYPE



TIPO	Art.	D	H
ISO 30 - B16	3991	15,733	15
ISO 40 - B12	3859	12,065	17
ISO 40 - B16	3860	15,733	17
ISO 40 - B18	3861	17,780	17
ISO 50 - B16	3992	15,733	20
ISO 50 - B18	3993	17,780	20



I Mandrini Autoserranti si trovano a pagina 62

Keyless Drill Chucks you can find at page 62

DIN 2080

MANDRINI AUTOSERRANTI INTEGRALI

ROTAZIONE DESTRA

MONOLITHIC DRILL CHUCKS - RIGHT SPIN



TIPO	Art.	RANGE	E	H			
ISO 30 - DC 13	8578	0,5 ÷ 13	50	90	9016	9021	2370
ISO 40 - DC 13	4331	0,5 ÷ 13	50	90	9016	9021	2370
ISO 40 - DC 16	4332	3 ÷ 16	57	105	9017	9023	2371
ISO 50 - DC 13	4333	0,5 ÷ 13	50	80	9016	9021	2370
ISO 50 - DC 16	4334	3 ÷ 16	57	100	9017	9023	2371



Forniti completi dell'apposita chiave

Supplied complete with suitable wrench

DIN 2080

MANDRINI AUTOSERRANTI INTEGRALI

ROTAZIONE DESTRA E SINISTRA

MONOLITHIC DRILL CHUCKS - RIGHT & LEFT SPIN



TIPO	Art.	RANGE	E	H	
ISO 40 - DCU 13	8579	0,5 ÷ 13	50	85	2372
ISO 40 - DCU 16	8580	3 ÷ 16	57	90	
ISO 50 - DCU 13	8581	0,5 ÷ 13	50	87	2372
ISO 50 - DCU 16	8582	3 ÷ 16	57	92	



Forniti completi dell'apposita chiave

Supplied complete with suitable wrench

DIN 2080

PORTAPINZA ER - GHIERA MINI

ER COLLET CHUCKS with MINI NUT



TIPO	Art.	H	D	RANGE			
ISO 30 - ER16 GM	2957	70	22	ER 16 1÷12	1229	5719	0364
ISO 40 - ER16 GM	2959	80	22	ER 16 1÷12	1229	5719	0364
ISO 40 - ER20 GM	2960	90	28	ER 20 1÷15	1230	5720	0787

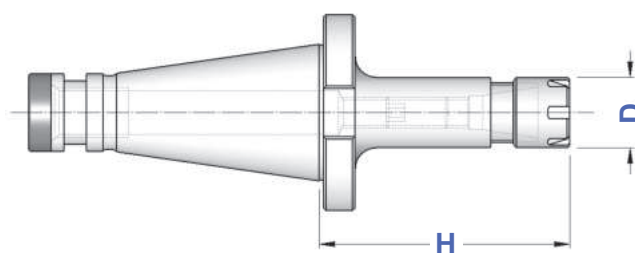

DIN 2080

PORTAPINZA ER - GHIERA ESAGONALE

ER COLLET CHUCKS with HEXAGONAL NUT



TIPO	Art.	D	RANGE			
ISO 30 - ER 16 GE / H 50	8332	28	ER 16 1÷12	1214	2906	0364
ISO 30 - ER 20 GE / H 50	8333	34	ER 20 1÷15	1215	2907	0787
ISO 40 - ER 16 GE / H 50	8334	28	ER 16 1÷12	1214	2906	0364
ISO 40 - ER 16 GE / H 100	8335					
ISO 40 - ER 20 GE / H 50	8336	34	ER 20 1÷15	1215	2907	0787
ISO 40 - ER 20 GE / H 100	8337					

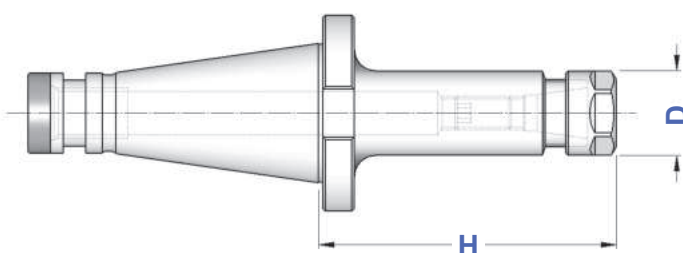



**DIN
2080**

PORTAPINZA ER - GHIERA STANDARD

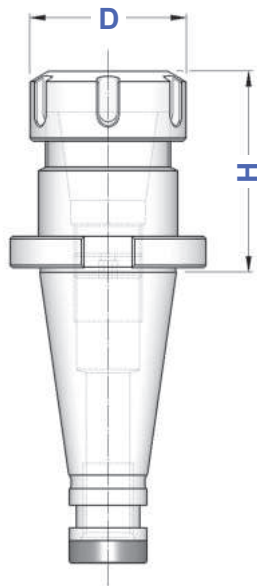
ER COLLET CHUCKS with STANDARD NUT



TIPO	Art.	D	RANGE			
ISO 30 - ER 16/H 50	2944	32	ER 16 1÷12	4993	3698	0364
ISO 30 - ER 20/H 50	2945	35	ER 20 1÷15	4994	3699	0787
ISO 30 - ER 25/H 40	2927	42	ER 25 1÷20	4995	3669	0996
ISO 30 - ER 25/H 75	2946					
ISO 30 - ER 32/H 50	2928	50	ER 32 2÷25	4996	3670	0988
ISO 30 - ER 32/H 70	3986					
ISO 30 - ER 32/H 100	3988					
ISO 30 - ER 40/H 75	3543	63	ER 40 3÷32	4997	3671	0821
ISO 30 - ER 40/H 100	3990					
ISO 40 - ER 16/H 50	2949	32	ER 16 1÷12	4993	3698	0364
ISO 40 - ER 16/H 100	3941					
ISO 40 - ER 20/H 50	2950	35	ER 20 1÷15	4994	3699	0787
ISO 40 - ER 20/H 100	2796					
ISO 40 - ER 25/H 50	2941	42	ER 25 1÷20	4995	3669	0996
ISO 40 - ER 25/H 100	2685					
ISO 40 - ER 32/H 50	2929	50	ER 32 2÷25	4996	3670	0988
ISO 40 - ER 32/H 70	2951					
ISO 40 - ER 32/H 100	2464					
ISO 40 - ER 32/H 130	2827					
ISO 40 - ER 32/H 160	2952					
ISO 40 - ER 40/H 50	2930	63	ER 40 3÷32	4997	3671	0821
ISO 40 - ER 40/H 70	2462					
ISO 40 - ER 40/H 100	2992					
ISO 40 - ER 50/H 100	2953	78	ER 50 6÷36	4998	3668	4055
ISO 50 - ER 25/H 65	2830	42	ER 25 1÷20	4995	3669	0996
ISO 50 - ER 25/H 100	2831					
ISO 50 - ER 25/H 140	2885					
ISO 50 - ER 32/H 70	2954	50	ER 32 2÷25	4996	3670	0988
ISO 50 - ER 32/H 100	2955					
ISO 50 - ER 32/H 140	2832					
ISO 50 - ER 40/H 75	2931	63	ER 40 3÷32	4997	3671	0821
ISO 50 - ER 40/H 100	2458					
ISO 50 - ER 40/H 140	2833					
ISO 50 - ER 50/H 70	2932	78	ER 50 6÷36	4998	3668	4055



Smontaconi Orientabili p.240
Tightening Fixtures p.240





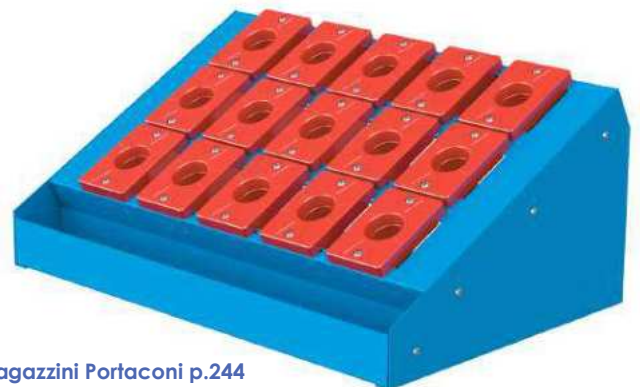

Tamponi Pulitori p.243
Taper Cleaners p.243



Magazzini Portaconi p.244
Tool Stores p.244

**KIT CON SERIE RIDOTTA
DI PINZE ER, MANDRINO E CHIAVE**





EQUIPMENT CASES WITH REDUCED SET OF ER COLLETS

TIPO	Art.				
KIT Rid ISO 30/H 40 - ER 25	7516	2927	7022	3669	0996: $\varnothing 4-6-8-10-12-16$
KIT Rid ISO 30/H 50 - ER 32	7517	2928	7023	3670	0988: $\varnothing 4-6-8-10-12-16-20$
KIT Rid ISO 40/H 50 - ER 25	7518	2941	7022	3669	0996: $\varnothing 4-6-8-10-12-16$
KIT Rid ISO 40/H 50 - ER 32	7519	2929	7023	3670	0988: $\varnothing 4-6-8-10-12-16-20$
KIT Rid ISO 40/H 70 - ER 32	7520	2951	7023	3670	0988: $\varnothing 4-6-8-10-12-16-20$
KIT Rid ISO 40/H 50 - ER 40	7521	2930	7024	3671	0821: $\varnothing 4-6-8-10-12-16-20-25$
KIT Rid ISO 50/H 70 - ER 32	7522	2954	7023	3670	0988: $\varnothing 4-6-8-10-12-16-20$
KIT Rid ISO 50/H 75 - ER 40	7523	2931	7024	3671	0821: $\varnothing 4-6-8-10-12-16-20-25$



**KIT CON SERIE COMPLETA
DI PINZE ER, MANDRINO E CHIAVE**

EQUIPMENT CASES WITH COMPLETE SET OF ER COLLETS

TIPO	Art.				
KIT ISO 30/H 40 - ER25	7500	2927	7022	3669	0996: $\varnothing 2 \div 16$ (15 Pinze)
KIT ISO 30/H 50 - ER32	7501	2928	7023	3670	0988: $\varnothing 3 \div 20$ (18 Pinze)
KIT ISO 40/H 50 - ER25	7502	2941	7022	3669	0996: $\varnothing 2 \div 16$ (15 Pinze)
KIT ISO 40/H 50 - ER32	7503	2929	7023	3670	0988: $\varnothing 3 \div 20$ (18 Pinze)
KIT ISO 40/H 70 - ER32	7504	2951	7023	3670	0988: $\varnothing 3 \div 20$ (18 Pinze)
KIT ISO 40/H 50 - ER40	7505	2930	7024	3671	0821: $\varnothing 4 \div 26$ (23 Pinze)
KIT ISO 50/H 70 - ER32	7506	2954	7023	3670	0988: $\varnothing 3 \div 20$ (18 Pinze)
KIT ISO 50/H 75 - ER40	7507	2931	7024	3671	0821: $\varnothing 4 \div 26$ (23 Pinze)



**DIN
2080**

MANDRINI PER PINZE EOC DIN 6388

DIN 6388 COLLET CHUCKS



TIPO	Art.	H	D	RANGE			
ISO 40 - EOC 16	4170	70	43	EOC 16 2÷16	4067	2908	0768
ISO 40 - EOC 25	3966	70	60	EOC 25 2÷25	4068	2909	0769
ISO 40 - EOC 32	3967	85	72	EOC 32 3÷32	4069	2910	0770
ISO 50 - EOC 25	3968	70	60	EOC 25 2÷25	4068	2909	0769
ISO 50 - EOC 32	3969	85	72	EOC 32 3÷32	4069	2910	0770

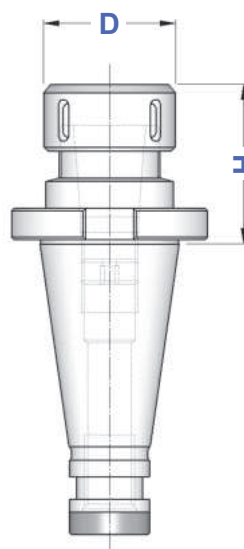

**Pinze, ghiera e chiavi
EOC - DIN 6388
si trovano da pagina 268**

Collets, nuts and wrenches
EOC - DIN 6388 type
you can find from page 268



SERIE RIDOTTA DI PINZE EOC

REDUCED SET OF EOC COLLETS

TIPO	Diametri	n° pinze	Art.	Art.
EOC 16 - Ridotta	Ø 4 - 6 - 8 - 10 - 12 - 16	6	7010	7016
EOC 25 - Ridotta	Ø 6 - 8 - 10 - 12 - 16 - 20 - 25	7	7011	7017
EOC 32 - Ridotta	Ø 6 - 8 - 10 - 12 - 16 - 20 - 25 - 32	8	7012	7018

**IN CONFEZIONI
SINGOLE**
IN SINGLE PACKS



Art.

**IN VALIGETTA
IN CASE**



Art.



SERIE COMPLETA DI PINZE EOC

COMPLETE SET OF EOC COLLETS

TIPO	Diametri	n° pinze	Art.	Art.
EOC 16 - Completa	da Ø 2 a Ø 16	15	7013	7019
EOC 25 - Completa	da Ø 2 a Ø 25	24	7014	7020
EOC 32 - Completa	da Ø 4 a Ø 32	29	7015	7021

**IN CONFEZIONI
SINGOLE**
IN SINGLE PACKS



Art.

**IN VALIGETTA
IN CASE**



Art.

**DIN
2080**

MANDRINI A FORTE SERRAGGIO
HIGH GRIP CHUCKS

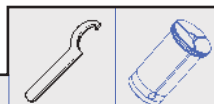

TIPO	Art.	H	E	D		
ISO 40 - PC 20	2997	65	50	20	2900	0809
ISO 40 - PC 32	2903	80	72	32	2910	0810
ISO 50 - PC 32	2904	85	72	32	2910	0810



Forniti completi dell'apposita chiave
Supplied complete with suitable wrench

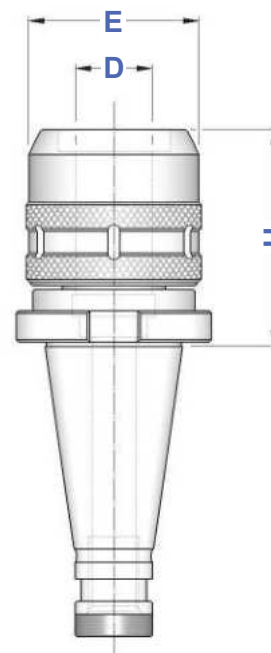

Pinze precisione standard pag. 270
Pinze alta precisione pag. 271

Standard precision collets page 270
High precision collets page 271



**KIT CON MANDRINO
CHIAVE E PINZE**
EQUIPMENT CASES WITH COLLET CHUCK
WRENCH AND COLLETS

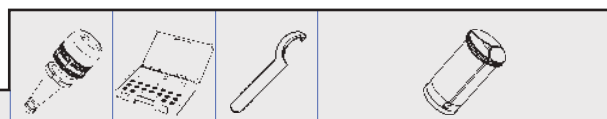

TIPO	Art.				
KIT ISO 40 - PC 20 / H 65	7449	2997	3695	2900	0809: \varnothing 6 - 8 - 10 - 12 - 16
KIT ISO 40 - PC 32 / H 80	7541	2903	3695	2910	0810: \varnothing 6 - 8 - 10 - 12 - 16 - 20 - 25
KIT ISO 50 - PC 32 / H 85	7542	2904	3695	2910	0810: \varnothing 6 - 8 - 10 - 12 - 16 - 20 - 25



DIN 2080

PORTAFRESE WELDON TIPO EXTRACORTO
SHORT TYPE END MILL HOLDERS

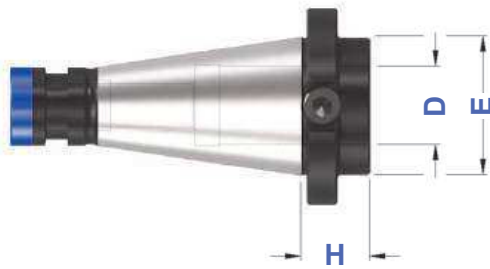

TIPO	Art.	D	H	E	
ISO 40 - WE 16/H 22	3090	16	22	48	0068
ISO 40 - WE 20/H 22	3091	20	22	48	0070
ISO 40 - WE 25/H 22	3092	25	22	48	0073
ISO 40 - WE 32/H 40	3109	32	40	44	0074
ISO 50 - WE 16/H 20	3093	16	20	48	0400
ISO 50 - WE 20/H 20	3094	20	20	48	4975
ISO 50 - WE 25/H 20	3095	25	20	65	0075
ISO 50 - WE 32/H 35	3096	32	35	72	4977

DIN 2080

PORTAFRESE WELDON
END MILL HOLDERS FOR DIN 1835-B SHANKS

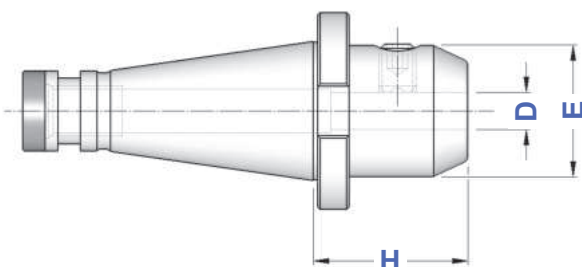

TIPO	Art.	D	H	E	
ISO 30 - WE 6/H 40	4442	6	40	25	4970
ISO 30 - WE 8/H 40	4443	8	40	28	4971
ISO 30 - WE 10/H 40	4444	10	40	35	4972
ISO 30 - WE 12/H 40	4445	12	40	42	4973
ISO 30 - WE 16/H 50	4447	16	50	48	4974
ISO 30 - WE 20/H 63	4449	20	63	52	4975
ISO 30 - WE 25/H 75	4450	25	75	65	4976
ISO 40 - WE 6/H 50	3647	6	50	25	4970
ISO 40 - WE 8/H 50	3648	8	50	28	4971
ISO 40 - WE 10/H 50	3649	10	50	35	4972
ISO 40 - WE 12/H 50	3650	12	50	42	4973
ISO 40 - WE 14/H 50	3610	14	50	44	4973
ISO 40 - WE 16/H 63	3651	16	63	48	4974
ISO 40 - WE 18/H 63	3611	18	63	50	4974
ISO 40 - WE 20/H 63	3652	20	63	52	4975
ISO 40 - WE 25/H 90	3653	25	90	64	4976
ISO 40 - WE 32/H 90	3654	32	90	72	4977
ISO 40 - WE 40/H 90	3312	40	90	80	4977
ISO 50 - WE 6/H 50	3655	6	50	25	4970
ISO 50 - WE 8/H 50	3656	8	50	28	4971
ISO 50 - WE 10/H 63	3657	10	63	35	4972
ISO 50 - WE 12/H 63	3658	12	63	42	4973
ISO 50 - WE 14/H 63	3340	14	63	44	4973
ISO 50 - WE 16/H 63	3659	16	63	48	4974
ISO 50 - WE 18/H 63	3341	18	63	50	4974
ISO 50 - WE 20/H 63	3660	20	63	52	4975
ISO 50 - WE 25/H 80	3661	25	80	64	4976
ISO 50 - WE 32/H 85	3662	32	85	72	4977
ISO 50 - WE 40/H 95	3663	40	95	78	4977



DIN 2080

MANDRINI PER UTENSILI ATTACCO WHISTLE NOTCH
END MILL HOLDERS FOR DIN 1835-E SHANKS



WN 6 ÷ WN 20
1 grano
1 screw



WN 25 ÷ WN 40
2 grani
2 screws

TIPO	Art.	D	H	E	
ISO 40 - WN 6/H 50	4458	6	50	25	4970
ISO 40 - WN 8/H 50	4459	8	50	28	4971
ISO 40 - WN 10/H 50	4460	10	50	35	4972
ISO 40 - WN 12/H 50	4461	12	50	42	4973
ISO 40 - WN 14/H 50	4462	14	50	44	4973
ISO 40 - WN 16/H 63	4463	16	63	48	4974
ISO 40 - WN 18/H 63	4464	18	63	50	4974
ISO 40 - WN 20/H 63	4465	20	63	52	4975
ISO 40 - WN 25/H 90	4466	25	90	65	4976
ISO 40 - WN 32/H 90	4467	32	90	72	4977
ISO 50 - WN 6/H 50	4468	6	50	25	4970
ISO 50 - WN 8/H 50	4469	8	50	28	4971
ISO 50 - WN 10/H 63	4470	10	63	35	4972
ISO 50 - WN 12/H 63	4471	12	63	42	4973
ISO 50 - WN 14/H 63	4472	14	63	44	4973
ISO 50 - WN 16/H 63	4473	16	63	48	4974
ISO 50 - WN 18/H 63	4474	18	63	50	4974
ISO 50 - WN 20/H 63	4475	20	63	52	4975
ISO 50 - WN 25/H 80	4476	25	80	65	4976
ISO 50 - WN 32/H 85	4477	32	85	72	4977
ISO 50 - WN 40/H 95	4478	40	95	78	4977

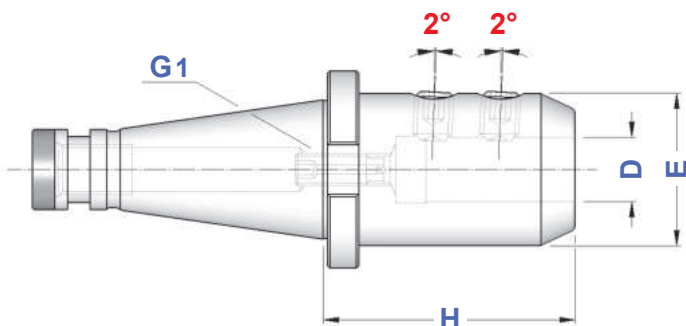
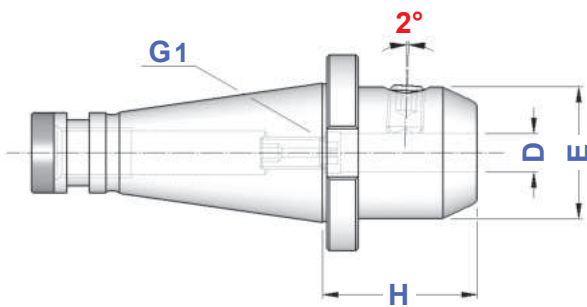
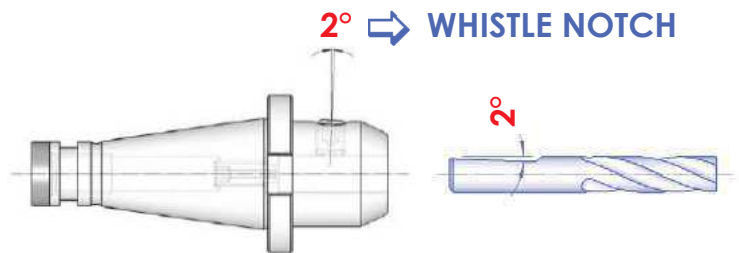

GRANO di PRESETTAGGIO con foro passante (G1)
PPRESETTING SCREW through hole (G1)

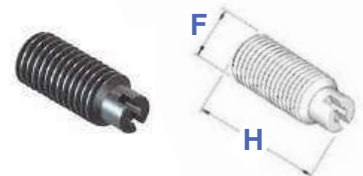

Art.	F x H	Passo
0233	M 5 x 16	0,8
0235	M 6 x 16	1
0238	M 8 x 20	1,25
0240	M 10 x 25	1,5
0245	M 12 x 30	1,75
1226	M 16 x 20	2
0212	M 20 x 20	2,5
0247	M 20 x 30	2,5

DIN 2080

RIDUZIONI A CONO MORSE PER PUNTE

MT ADAPTERS FOR TWIST DRILLS



TIPO	Art.	CM	H	E
ISO 30 - CM 1 PUNTE	8517	1	60	25
ISO 30 - CM 2 PUNTE	3873	2	60	32
ISO 30 - CM 3 PUNTE	3874	3	70	40
ISO 40 - CM 1 PUNTE	8518	1	50	25
ISO 40 - CM 2 PUNTE	8520	2	50	32
ISO 40 - CM 3 PUNTE	3614	3	65	40
ISO 40 - CM 4 PUNTE	3615	4	95	48
ISO 50 - CM 1 PUNTE	8523	1	45	25
ISO 50 - CM 2 PUNTE	8525	2	60	32
ISO 50 - CM 3 PUNTE	8527	3	65	40
ISO 50 - CM 4 PUNTE	3619	4	70	48
ISO 50 - CM 5 PUNTE	3620	5	100	63

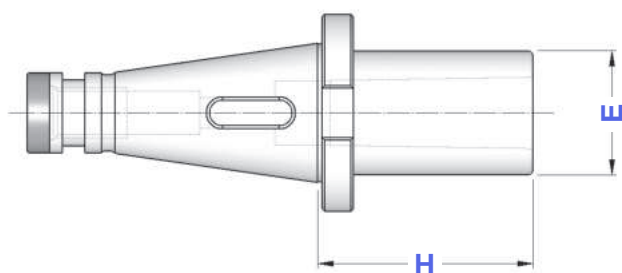



DIN 2080

RIDUZIONI A CONO MORSE PER FRESE

MT ADAPTERS FOR MILLING CUTTERS



TIPO	Art.	CM	H	E		
ISO 30 - CM 2 FRESE	3876	2	60	32	7422	4569
ISO 30 - CM 3 FRESE	3877	3	80	40	7423	4570
ISO 40 - CM 2 FRESE	3622	2	50	32	7422	4569
ISO 40 - CM 3 FRESE	3623	3	65	40	7423	4570
ISO 40 - CM 4 FRESE	3624	4	95	48	7424	4571
ISO 50 - CM 2 FRESE	3626	2	60	32	7422	4569
ISO 50 - CM 3 FRESE	3627	3	65	40	7423	4570
ISO 50 - CM 4 FRESE	3628	4	65	48	7424	4571
ISO 50 - CM 5 FRESE	3629	5	120	63	7425	4572

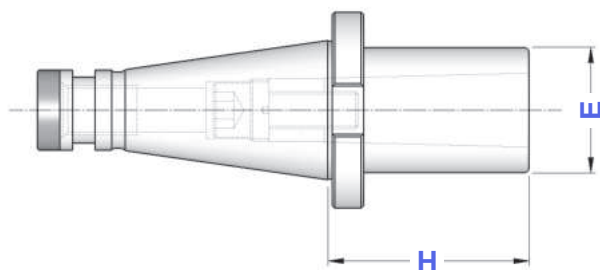

DIN 2080

**RIDUZIONI A CONO MORSE PUNTE + FRESE
COMBinate**

COMBI MT ADAPTERS: TWIST DRILLS + MILLING CUTTERS

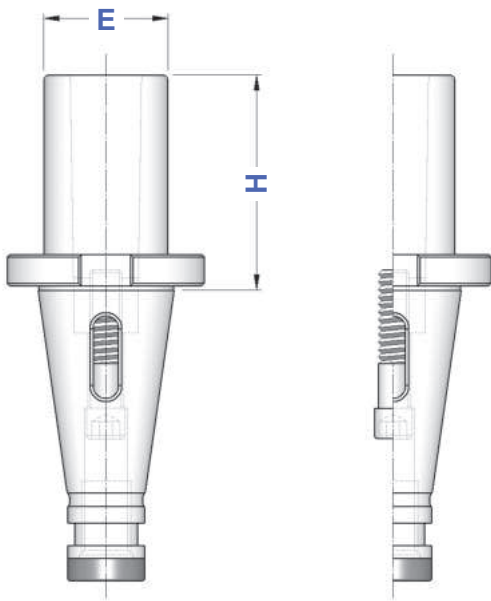

TIPO	Art.	CM	H	E
ISO 40 - CM 1 P+F	3612	1	50	25
ISO 40 - CM 2 P+F	3613	2	50	32
ISO 40 - CM 3 P+F	8532	3	65	40
ISO 50 - CM 1 P+F	3616	1	45	25
ISO 50 - CM 2 P+F	3617	2	60	32
ISO 50 - CM 3 P+F	3618	3	65	40
ISO 50 - CM 4 P+F	8533	4	70	48



COMBinate PUNTE + FRESE
COMBI TWIST DRILL + MILLING CUTTERS

DIN 2080

**RIDUZIONI A CONO MORSE PER PUNTE E PUNTE + FRESE
TIPO PROLUNGATO**

EXTENDED MT ADAPTERS: TWIST DRILLS AND TWIST DRILLS + MILLING CUTTERS

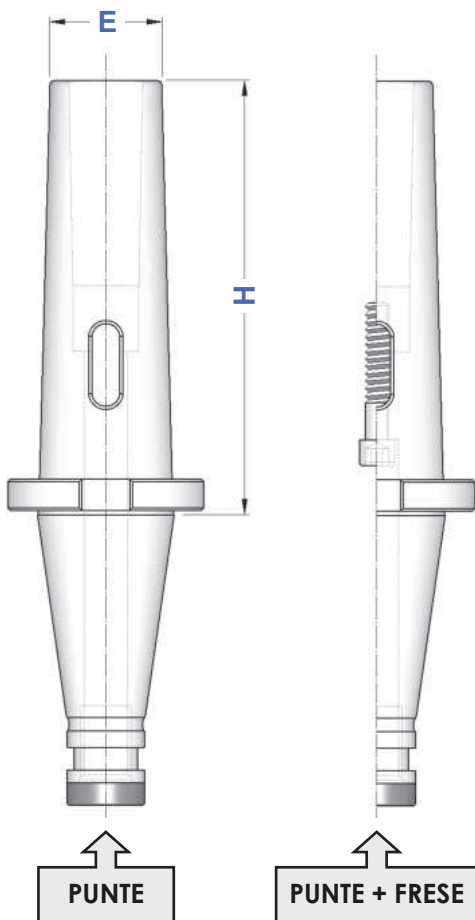

TIPO	PUNTE		CM	H	E
	Art.	Art.			
ISO 40 - CM 1	8519	3544	1	95	18
ISO 40 - CM 2	8521	3545	2	110	25
ISO 40 - CM 3	8522	3546	3	130	33
ISO 40 - CM 4	3548	—	4	150	40
ISO 50 - CM 1	8524	3785	1	120	18
ISO 50 - CM 2	8526	3786	2	140	25
ISO 50 - CM 3	8528	3787	3	150	33
ISO 50 - CM 4	8529	3788	4	180	40
ISO 50 - CM 5	8530	—	5	220	55



PUNTE

PUNTE + FRESE

**DIN
2080**

PORTAFRESE FISSI
FACE MILL HOLDERS

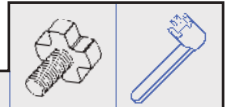

TIPO	Art.	D	L	E	E _{max}		
ISO 30 - D.13 FISSO/H 35	5498	13	12	28	—	0482	—
ISO 30 - D.16 FISSO/H 35	4200	16	17	38	—	4985	4562
ISO 30 - D.22 FISSO/H 35	4201	22	19	48	—	4986	4563
ISO 30 - D.27 FISSO/H 35	4202	27	21	58	—	4987	4564
ISO 40 - D.13 FISSO/H 45	5499	13	12	28	—	0482	—
ISO 40 - D.16 FISSO/H 45	5500	16	17	38	—	4985	4562
ISO 40 - D.16 FISSO/H 100	9800						
ISO 40 - D.16 FISSO/H 130	5501						
ISO 40 - D.22 FISSO/H 45	5502	22	19	48	—	4986	4563
ISO 40 - D.22 FISSO/H 100	9801				61		
ISO 40 - D.22 FISSO/H 130	5503						
ISO 40 - D.27 FISSO/H 45	5504	27	21	58	—	4987	4564
ISO 40 - D.27 FISSO/H 100	9802						
ISO 40 - D.27 FISSO/H 130	5505						
ISO 40 - D.32 FISSO/H 50	5506	32	24	78	—	4988	4565
ISO 40 - D.32 FISSO/H 100	9803			66			
ISO 40 - D.32 FISSO/H 130	5507						
ISO 40 - D.40 FISSO/H 55	5508	40	27	88	—	4989	4566
ISO 40 - D.40 FISSO/H 100	9804						
ISO 50 - D.16 FISSO/H 45	5509	16	17	38	—	4985	4562
ISO 50 - D.16 FISSO/H 100	9805						
ISO 50 - D.16 FISSO/H 160	5510						
ISO 50 - D.22 FISSO/H 45	5511	22	19	48	—	4986	4563
ISO 50 - D.22 FISSO/H 100	9806						
ISO 50 - D.22 FISSO/H 160	5512						
ISO 50 - D.27 FISSO/H 45	5513	27	21	58	—	4987	4564
ISO 50 - D.27 FISSO/H 100	9807						
ISO 50 - D.27 FISSO/H 160	5514						
ISO 50 - D.32 FISSO/H 50	5515	32	24	78	—	4988	4565
ISO 50 - D.32 FISSO/H 100	9808			66			
ISO 50 - D.32 FISSO/H 160	5516						
ISO 50 - D.40 FISSO/H 50	5517	40	27	88	—	4989	4566
ISO 50 - D.40 FISSO/H 100	9809						
ISO 50 - D.40 FISSO/H 160	5518						

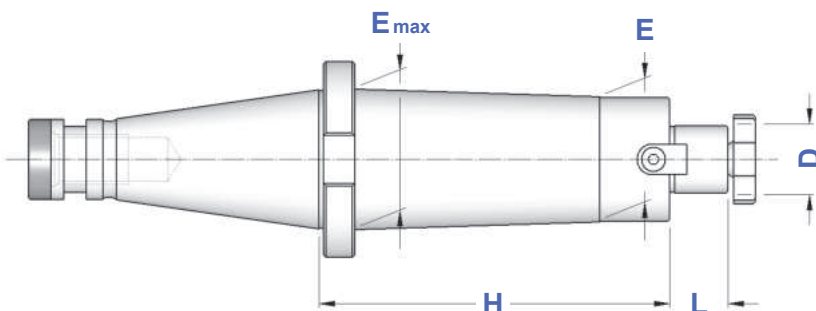
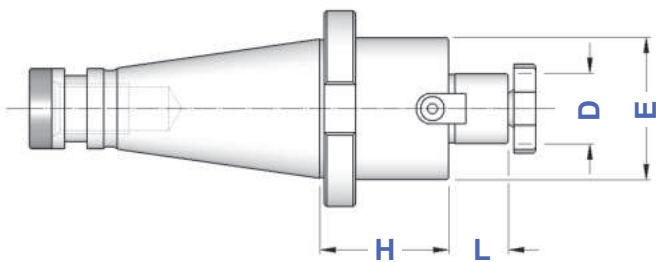

DIN 2080

PORTAFRESE COMBINATI
DIN 6358 COMBI SHELL MILL HOLDERS

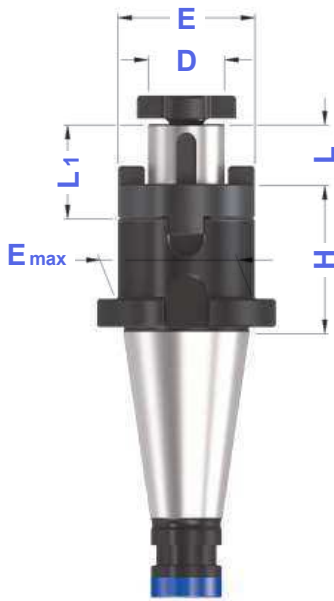
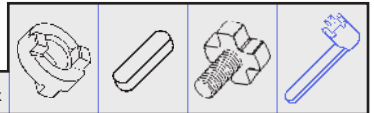

TIPO	Art.	D	L1	L	E	Emax				
ISO 30 - D.16 C/H 35	3878	16	27	17	32	-	4090	0115	4985	4562
ISO 30 - D.22 C/H 35	3879	22	31	19	40	-	4091	0116	4986	4563
ISO 30 - D.27 C/H 35	3880	27	33	21	48	-	4092	0122	4987	4564
ISO 30 - D.32 C/H 50	3881	32	38	24	58	-	4093	0125	4988	4565
ISO 40 - D.16 C/H 52	3817	16	27	17	32	-	4090	0115	4985	4562
ISO 40 - D.16 C/H 100	4189					40				
ISO 40 - D.22 C/H 52	3818	22	31	19	40	-	4091	0116	4986	4563
ISO 40 - D.22 C/H 100	4190					44				
ISO 40 - D.27 C/H 52	3819	27	33	21	48	-	4092	0122	4987	4564
ISO 40 - D.27 C/H 100	4191									
ISO 40 - D.32 C/H 52	3820	32	38	24	58	-	4093	0125	4988	4565
ISO 40 - D.32 C/H 100	4192									
ISO 40 - D.40 C/H 52	3821	40	41	27	70	-	4094	0133	4989	4566
ISO 50 - D.16 C/H 55	3822	16	27	17	32	-	4090	0115	4985	4562
ISO 50 - D.16 C/H 100	4194					50				
ISO 50 - D.22 C/H 55	3823	22	31	19	40	-	4091	0116	4986	4563
ISO 50 - D.22 C/H 100	4195					60				
ISO 50 - D.27 C/H 55	3824	27	33	21	48	-	4092	0122	4987	4564
ISO 50 - D.27 C/H 100	4196					60				
ISO 50 - D.32 C/H 55	3825	32	38	24	58	-	4093	0125	4988	4565
ISO 50 - D.32 C/H 100	4197									
ISO 50 - D.40 C/H 55	3826	40	41	27	70	-	4094	0133	4989	4566
ISO 50 - D.40 C/H 100	4198									



DIN 2080

PORTAFRESE CON CHIAVETTA DI TRASCINAMENTO
MILLING CUTTER HOLDERS WITH FEATHER KEY



TIPO	Art.	D	H	L	E			
ISO 30 - D.16 CHT	0134	16	35	30	28	0147	4985	4562
ISO 30 - D.22 CHT	0135	22	35	40	36	0148	4986	4563
ISO 30 - D.27 CHT	0136	27	35	60	43	0149	4987	4564
ISO 40 - D.16 CHT	4205	16	37	30	28	0147	4985	4562
ISO 40 - D.22 CHT	4207	22	37	40	36	0148	4986	4563
ISO 40 - D.27 CHT	4209	27	37	60	43	0149	4987	4564
ISO 40 - D.32 CHT	4211	32	37	60	48	0150	4988	4565



**DIN
2080**

ATTACCHI PER FRESE AD INSERTI
FACE MILL HOLDERS FOR FACE MILLING CUTTERS



TIPO	Art.	D	H	E	C	F	T	
ISO 40 - D. 40 FM	4223	40	20	89	66,7	M12	15,9	4989
ISO 40 - D. 60 FM	4225	60	30	129	101,6	M16	25,4	—
ISO 50 - D. 40 FM	4226	40	30	89	66,7	M12	15,9	4989
ISO 50 - D. 60 FM	4228	60	30	129	101,6	M16	25,4	—

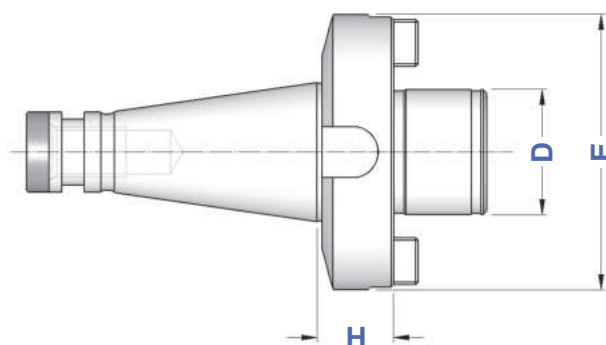
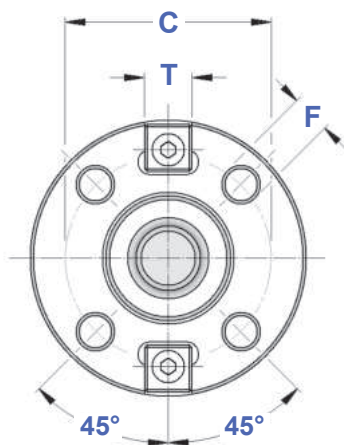

**DIN
2080**

CENTRATORI PER FRESE AD INSERTI
CENTERINGS FOR MILLING CUTTERS



TIPO	Art.	H	E
ISO 40 - D. 40 CF	4012	29	40
ISO 50 - D. 60 CF	4025	39	60

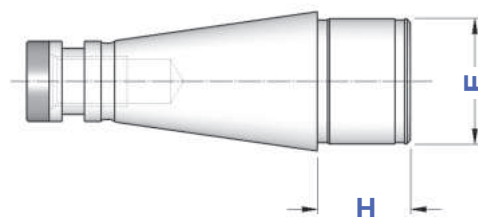

DIN 2080

**MASCHIATORI A CAMBIO RAPIDO CON
DOPPIA COMPENSAZIONE**
DOUBLE COMPENSATION QUICK CHANGE TAPPING CHUCKS



TIPO	Art.	H	E	B	COMPENSAZIONE	
ISO 30 - B. 1	3536	52	38	19	- 7,5 + 7,5	M 3 ÷ M 12 (*M18)
ISO 30 - B. 2	3537	85	55	31	- 15,0 + 15,0	M 6 ÷ M 20 (*M30)
ISO 40 - B. 1	3538	53	38	19	- 7,5 + 7,5	M 3 ÷ M 12 (*M18)
ISO 40 - B. 2	3539	77	55	31	- 15,0 + 15,0	M 6 ÷ M 20 (*M30)
ISO 40 - B. 3	3540	142	79	48	- 20,0 + 20,0	M14 ÷ M 33 (*M48)
ISO 50 - B. 1	4199	57	38	19	- 9,0 + 9,0	M 3 ÷ M 12 (*M18)
ISO 50 - B. 2	3541	79	55	31	- 15,0 + 15,0	M 6 ÷ M 20 (*M30)
ISO 50 - B. 3	3542	125	79	48	- 20,0 + 20,0	M14 ÷ M 33 (*M48)

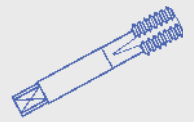

* Bussole con GRANI
Adapters with SCREWS

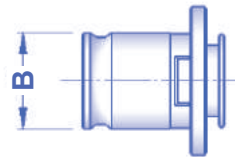
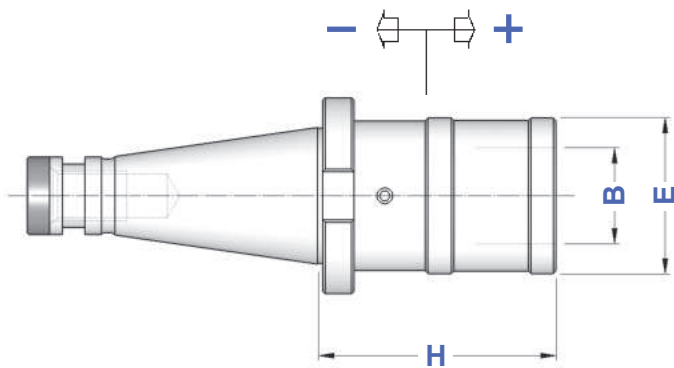

**Bussole a maschiare
da pag. 235**
Tapping Adapters
from page 235

DIN 2080

**MASCHIATORI A CAMBIO RAPIDO
SENZA COMPENSAZIONE**
QUICK CHANGE TAPPING CHUCKS WITHOUT COMPENSATION



TIPO	Art.	H	E	B	
ISO 30 - B. 1 FISSO	4941	50	33	19	M 3 ÷ M 12 (*M18)
ISO 30 - B. 2 FISSO	4942	73	50	31	M 6 ÷ M 20 (*M30)
ISO 40 - B. 1 FISSO	4943	52	33	19	M 3 ÷ M 12 (*M18)
ISO 40 - B. 2 FISSO	4944	74	50	31	M 6 ÷ M 20 (*M30)
ISO 50 - B. 1 FISSO	5108	55	33	19	M 3 ÷ M 12 (*M18)
ISO 50 - B. 2 FISSO	5109	78	50	31	M 6 ÷ M 20 (*M30)

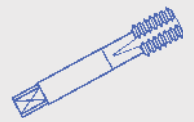

* Bussole con GRANI
Adapters with SCREWS

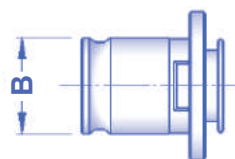
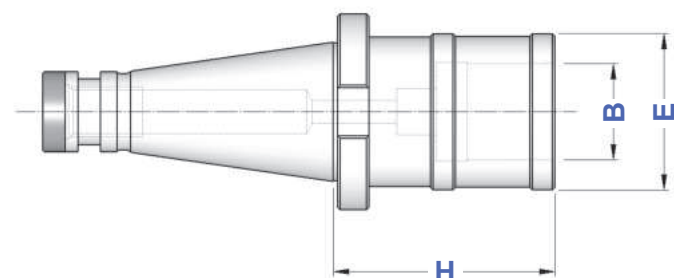

**Bussole a maschiare
da pag. 235**
Tapping Adapters
from page 235

DIN 2080

BARRE A STELO TENERO
BLANK BARS

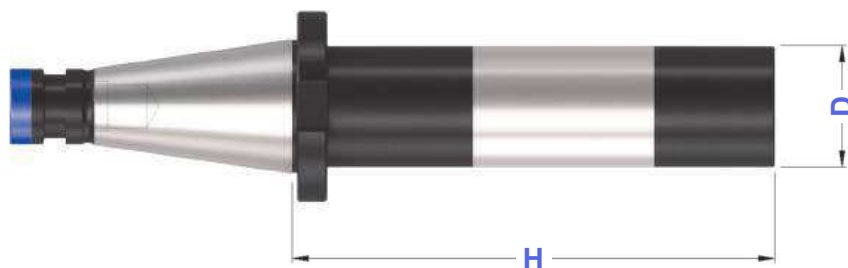

TIPO	Art.	D	H
ISO 40 - D. 40 ST / H 160	4374	40	160
ISO 40 - D. 63 ST / H 160	4378	63	160
ISO 40 - D. 63 ST / H 250	4379	63	250
ISO 50 - D. 80 ST / H 300	4387	80	300

DIN 2080

RIDUZIONI DA ISO A ISO/TC/BT
NT TO NT/SK/BT REDUCTIONS

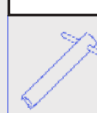

TIPO	Art.	H	E		DIN 2080	BT DIN 69871	
ISO 40 - ISO 30/TC 30/BT 30	4235	50	50	* 7423	* 7410	* 0177	4570
ISO 50 - ISO 40/TC 40/BT 40	4237	63	68	* 7424	* 7411	* 0179	4571
ISO 50 - ISO 50/TC 50/BT 50	8536	100	100	* 7426	* 7417	* 0254	4780

* Compresi nella fornitura
Included in the supply

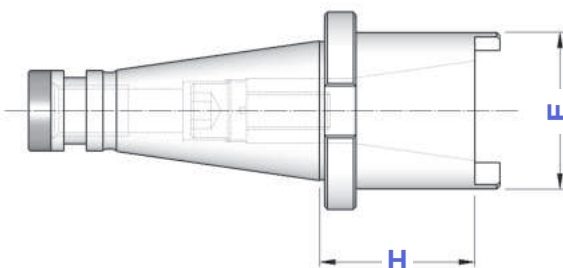

DIN 2080

RIDUZIONI PASSANTI DA ISO A ISO
NT TO NT OPEN-ENDED REDUCTIONS

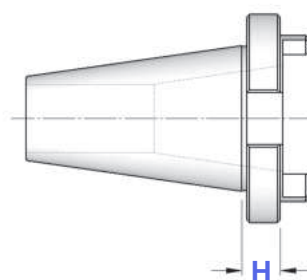

TIPO	Art.	H
ISO 40 - IP 30	8828	12
ISO 50 - IP 40	8829	16

CARATTERISTICHE TECNICHE CONI DIN 69871 (ISO 7388-1)

SK TAPERS DIN 69871 (ISO 7388-1) STANDARD FEATURES

FORMA A

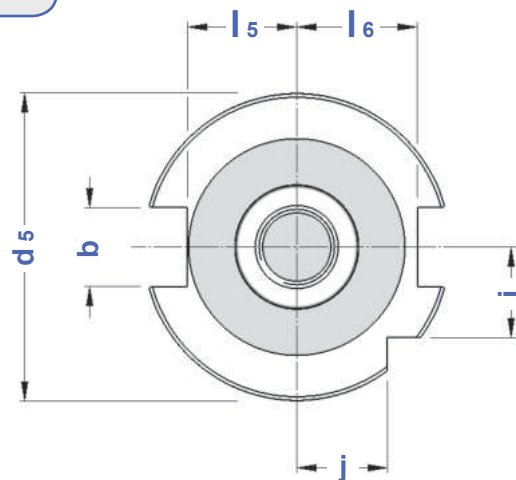
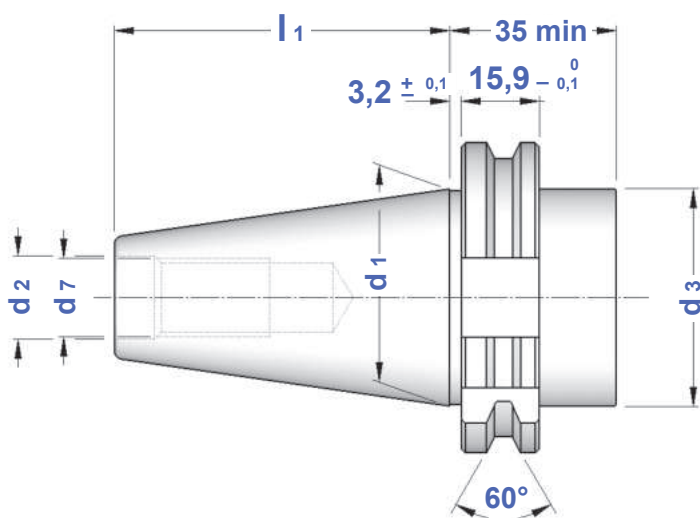

FORMA AD

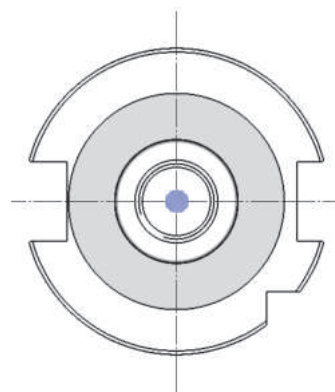
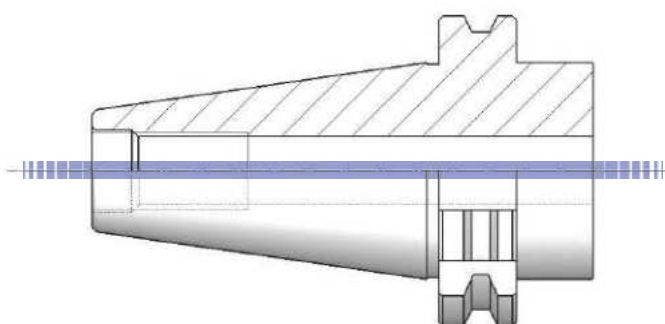

FORMA AD+B (AD/AF)

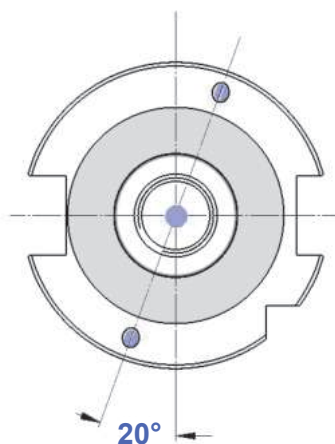
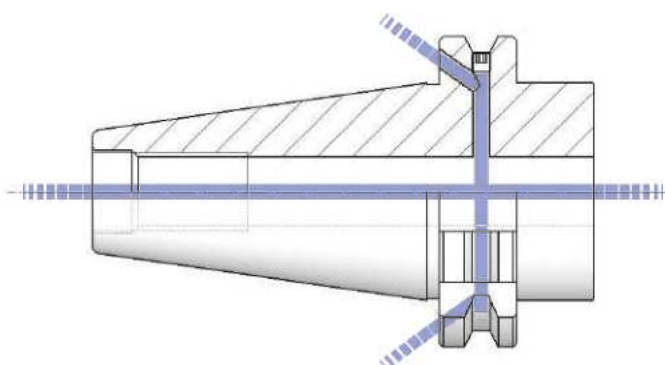

CONO	b	d1	d2	d3	d5	d7	j	l1	l5	l6	PRECISIONE
SK 30 = TC 30	16,1	31,75	13	45	50	M 12	15	47,8	16,3	18,8	
SK 40 = TC 40	16,1	44,45	17	50	63,55	M 16	18,5	68,4	22,7	25	
SK 45 = TC 45	19,3	57,15	21	63	82,55	M 20	24	82,7	29,1	31,3	
SK 50 = TC 50	25,7	69,85	25	80	97,50	M 24	30	101,75	35,5	37,7	

INDICE DELL' ATTACCO DIN 69871 (ISO 7388-1)

INDEX OF SK SHANK (DIN 69871 / ISO 7388 -1)

AUTOSERRANTI INTEGRALI

MONOLITHIC DRILL CHUCKS

pag. 102



attacchi per AUTOSERRANTI

SHANKS for
DIN 238 DRILL CHUCKS

pag. 103



PORTAPINZA ER EXTRACORTI

ER SHORT COLLET CHUCKS
with INNER NUT

pag. 103



PORTAPINZA ER ghiera MINI

ER MINI NUT
COLLET CHUCKS

pag. 104



PORTAPINZA ER ghiera ESAGONALE

ER HEXAGONAL NUT
COLLET CHUCKS

pag. 105



PORTAPINZA ER ghiera STANDARD

ER STANDARD NUT
COLLET CHUCKS

pag. 106 - 107



mandrini per PINZE EOC

DIN 6388 EOC
COLLET CHUCKS

pag. 108



FORTE SERRAGGIO

HIGH GRIP CHUCKS

pag. 109



SERRAGGIO IDRAULICO

HYDRAULIC CHUCKS

pag. 110



BARRE a STELO TENERO

BLANK BARS

pag. 111



BARRE di CONTROLLO

TEST ARBORS

pag. 111



PORTA PUNTE ad INSERTI

INDEXABLE DRILL HOLDERS

pag. 112



PORTAFRESE WELDON EXTRACORTI

SHORT TYPE END MILL HOLDERS

pag. 113



PORTAFRESE WELDON

END MILL HOLDERS
for DIN 1835-B SHANK

pag. 114 - 115



WELDON con CANALI di REFRIGERAZIONE

END MILL HOLDERS
with COOLANT CHANNELS

pag. 116



PORTAFRESE WHISTLE NOTCH

END MILL HOLDERS
for DIN 1835-E SHANK

pag. 117



➔ segue
continue

**riduzioni a CONO MORSE
per PUNTE e per FRESE**

*MT ADAPTERS for TWIST DRILLS and
for MILLING CUTTERS*
pag. 118 - 119



PORTAFRESE ad INSERTI

*FACE MILL HOLDERS for
FACE MILLING CUTTERS*

pag. 122



PORTAFRESE COMBINATI

*COMBI
SHELL MILL HOLDERS*

pag. 123



MASCHIATORI

TAPPING CHUCKS

pag. 125



riduzioni da ISO a HSK

ISO to HSK ADAPTERS

pag. 126



CODOLI di AGGANCI

PULL STUDS

pag. 221



**SMONTACONI
ORIENTABILI**

*ORIENTABLE
TIGHTENING FIXTURES*
pag. 240



PORTAFRESE FISSI

FACE MILL HOLDERS

pag. 120 - 121



**P/FRESE con CHIAVETTA
di TRASCINAMENTO**

*MILLING CUTTER HOLDERS
with FEATHER KEY*

pag. 122



**PORTA FRESE con
ATTACCO FILETTATO**

*THREADED SHANK
MILLING CUTTERS HOLDERS*

pag. 124



riduzioni da ISO a ISO

ISO to ISO ADAPTERS

pag. 126



**riduzioni da ISO
a POLIGONALE**

*ISO to POLYGONAL
ADAPTERS*

pag. 126



TAMPONI PULITORI

TAPER CLEANERS

pag. 243



MAGAZZINI PORTACONI

TOOL STORES

pag. 244 - 245



DIN 69871 ISO 7388-1	MANDRINI AUTOSERRANTI INTEGRALI ROTAZIONE DESTRA MONOLITHIC DRILL CHUCKS - RIGHT SPIN	FORMA A

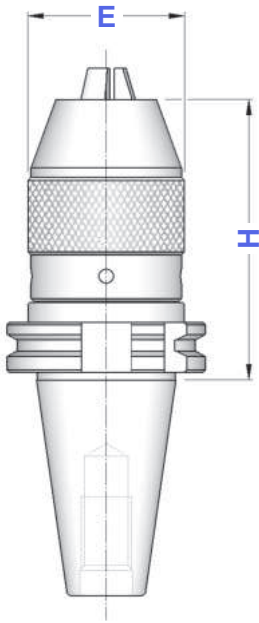

TIPO	FORMA A		RANGE	E	H			
	Art.	Art.						
TC 30 - DC 13	8583		0,5 ÷ 13	50	100	9016	9021	2370
TC 40 - DC 13	4398		0,5 ÷ 13	50	90	9016	9021	2370
TC 40 - DC 16	4399		3 ÷ 16	57	115	9017	9023	2371
TC 50 - DC 13	4402		0,5 ÷ 13	50	100	9016	9021	2370
TC 50 - DC 16	4403		3 ÷ 16	57	105	9017	9023	2371



Forniti completi dell'apposita chiave
Supplied complete with suitable wrench

DIN 69871 ISO 7388-1	MANDRINI AUTOSERRANTI INTEGRALI ROTAZIONE DESTRA E SINISTRA MONOLITHIC DRILL CHUCKS - RIGHT & LEFT SPIN	FORMA AD
		FORMA AD+B (AD/AF)

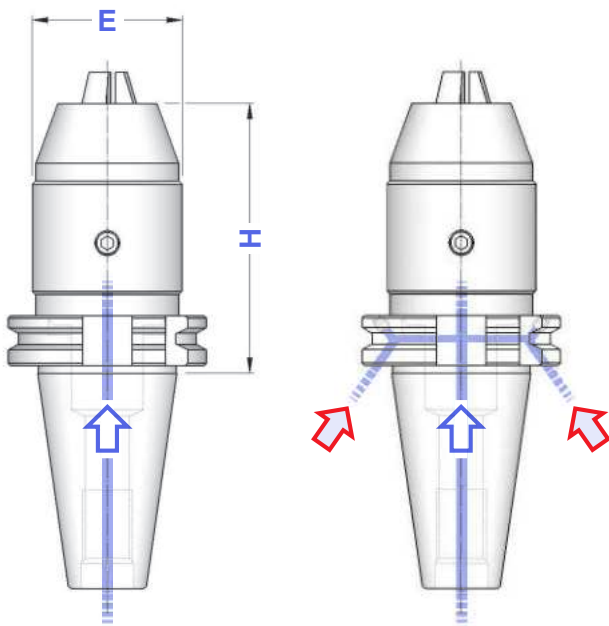

TIPO	FORMA AD	FORMA AD+B	RANGE	E	H	
	Art.	Art.				
TC 40 - DCU 13	8585	8589	0,5 ÷ 13	50	90	2372
TC 40 - DCU 16	8586	8590	3 ÷ 16	50	95	
TC 50 - DCU 13	8587	8591	0,5 ÷ 13	50	90	2372
TC 50 - DCU 16	8588	8592	3 ÷ 16	50	95	



Forniti completi dell'apposita chiave
Supplied complete with suitable wrench

FORMA AD

FORMA AD+B

DIN 69871 ISO 7388-1	ATTACCHI PER MANDRINI AUTOSERRANTI <i>SHANKS FOR DRILL CHUCKS DIN 238 / ISO 239 TYPE</i>	FORMA A
--------------------------------	--	----------------

Balanced G 6,3
8.000 rpm

FORMA A

TIPO	Art.	D	H
TC 30 - B 12	3867	12,065	40
TC 30 - B 16	3868	15,733	40
TC 40 - B 12	3869	12,065	40
TC 40 - B 16	3870	15,733	40
TC 40 - B 18	3871	17,780	40
TC 50 - B 16	3998	15,733	40
TC 50 - B 18	3999	17,780	40

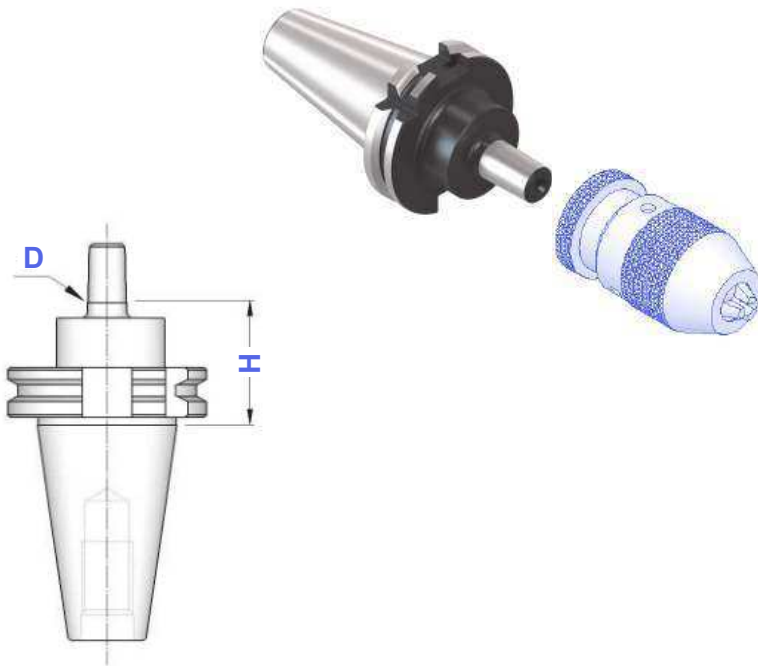





I Mandrini Autoserranti si trovano a pagina 62
Keyless Drill Chucks you can find at page 62

DIN 69871 ISO 7388-1	PORTAPINZA ER EXTRACORTI <i>ER SHORT COLLET CHUCKS with INNER NUT</i>	FORMA AD
--------------------------------	---	-----------------

Balanced G 6,3
15.000 rpm

FORMA AD

TIPO	Art.	H	RANGE			
TC 40 - ER25 GA	8038	21	ER25 1÷20	2870	3172	0996
TC 40 - ER32 GA	3370	21	ER32 2÷25	2871	3173	0988
TC 50 - ER32 GA	3371	21	ER32 2÷25	2871	3173	0988

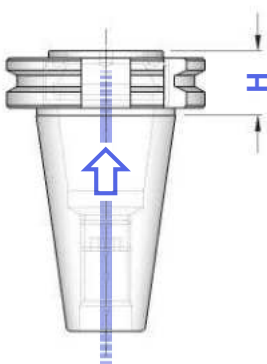
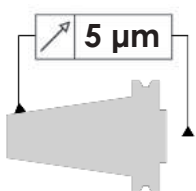

FORMA AD



DIN 69871

ISO 7388-1

PORTAPINZA ER - GHIERA MINI



ER COLLET CHUCKS with MINI NUT

FORMA AD

FORMA AD+B (AD/AF)

Balanced	G 6,3
≤ H130	15.000 rpm
≥ H160	8.000 rpm



TIPO	FORMA AD	FORMA AD+B	D	RANGE			
	Art.	Art.					
TC30 - ER 11 GM / H 80	4072	—	16	ER11 1÷8	0432	5718	5573
TC30 - ER 16 GM / H 80	3001	—	22	ER16 1÷12	1229	5719	0364
TC30 - ER 16 GM / H120	3432	—					
TC40 - ER 11 GM / H 70	4073	4720	16	ER11 1÷8	0432	5718	5573
TC40 - ER 11 GM / H100	4020	4721					
TC40 - ER 11 GM / H130	4057	4722					
TC40 - ER 11 GM / H160	3416	4723					
TC40 - ER 16 GM / H 70	3417	4724	22	ER16 1÷12	1229	5719	0364
TC40 - ER 16 GM / H100	4074	4748					
TC40 - ER 16 GM / H130	3433	4749					
TC40 - ER 16 GM / H160	4014	4021					
TC40 - ER 16 GM / H200	3418	4026					
TC40 - ER 20 GM / H 70	3005	4000	28	ER20 1÷15	1230	5720	0787
TC40 - ER 20 GM / H100	4015	4022					
TC40 - ER 20 GM / H130	3434	4750					
TC40 - ER 20 GM / H160	4016	4691					
TC40 - ER 20 GM / H200	4017	4729					
TC40 - ER 25 GM / H 70	3007	4001	35	ER25 1÷20	1231	5721	0996
TC40 - ER 25 GM / H100	4075	4751					
TC40 - ER 25 GM / H130	3435	4730					
TC40 - ER 25 GM / H160	3436	4752					
TC40 - ER 25 GM / H200	3437	4753					
TC50 - ER 16 GM / H100	3008	4046	22	ER16 1÷12	1229	5719	0364
TC50 - ER 16 GM / H130	3440	4756					
TC50 - ER 16 GM / H160	4018	4693					
TC50 - ER 16 GM / H200	4019	4757					
TC50 - ER 20 GM / H100	3010	4047	28	ER20 1÷15	1230	5720	0787
TC50 - ER 20 GM / H130	3441	4758					
TC50 - ER 20 GM / H160	3419	4760					
TC50 - ER 20 GM / H200	3012	4070					
TC50 - ER 25 GM / H100	3016	4071	35	ER25 1÷20	1231	5721	0996
TC50 - ER 25 GM / H130	3024	4483					
TC50 - ER 25 GM / H160	3420	4759					
TC50 - ER 25 GM / H200	3025	4484					

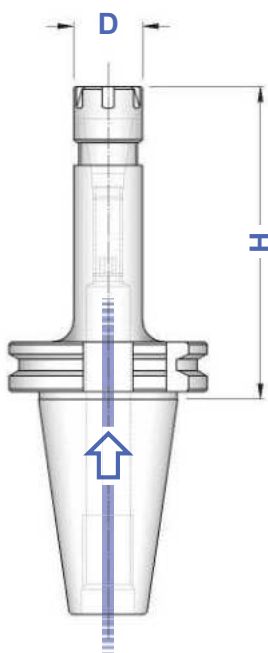

FORMA AD

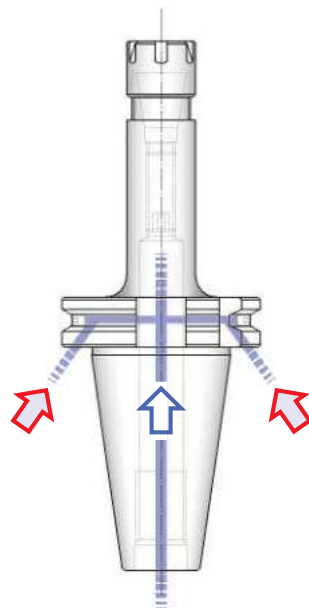

FORMA AD+B



DIN 69871

ISO 7388-1

PORTAPINZA ER - GHIERA ESAGONALE



ER COLLET CHUCKS with HEXAGONAL NUT

FORMA AD

FORMA AD+B (AD/AF)

Balanced	G 6,3
≤ H130	15.000 rpm
≥ H160	8.000 rpm



TIPO	FORMA AD	FORMA AD+B	DOPPIO CONTATTO	D	RANGE			
	Art.	Art.	Art.					
TC 30 - ER 16 GE / H 55 TC 30 - ER 16 GE / H 100	8048 8049	—	—	28	ER16 1÷12	1214	2906	0364
TC 30 - ER 20 GE / H 55 TC 30 - ER 20 GE / H 100	8050 8051	—	—	34	ER20 1÷15	1215	2907	0787
TC 40 - ER 11 GE / H 70 TC 40 - ER 11 GE / H 100 TC 40 - ER 11 GE / H 130 TC 40 - ER 11 GE / H 160	3336 3337 3338 3339	4725 4726 4727 4728	—	19	ER11 1÷8	1157	2905	5573
TC 40 - ER 16 GE / H 70 TC 40 - ER 16 GE / H 100 TC 40 - ER 16 GE / H 130 TC 40 - ER 16 GE / H 160 TC 40 - ER 16 GE / H 200	8052 8053 8054 8055 8056	8068 8069 8070 8071 8072	10036 10037 — — —	28	ER16 1÷12	1214	2906	0364
TC 40 - ER 20 GE / H 70 TC 40 - ER 20 GE / H 100 TC 40 - ER 20 GE / H 130 TC 40 - ER 20 GE / H 160 TC 40 - ER 20 GE / H 200	8057 8058 8059 8060 8061	8073 8074 8075 8076 8077	10041 10042 — — —	34	ER20 1÷15	1215	2907	0787
TC 50 - ER 16 GE / H 100 TC 50 - ER 16 GE / H 160 TC 50 - ER 16 GE / H 200	8062 8063 8064	8078 8079 8080	— — —	28	ER16 1÷12	1214	2906	0364
TC 50 - ER 20 GE / H 100 TC 50 - ER 20 GE / H 160 TC 50 - ER 20 GE / H 200	8065 8066 8067	8081 8082 8083	— — —	34	ER20 1÷15	1215	2907	0787

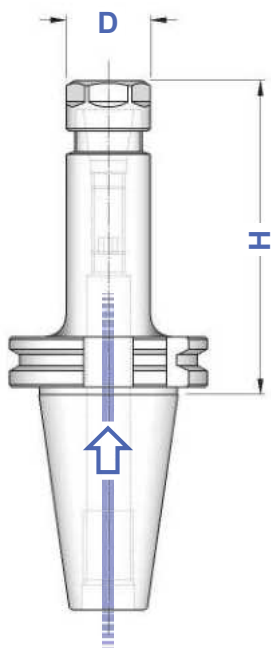

FORMA AD

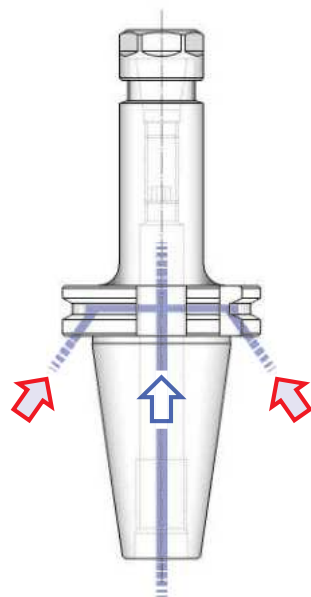

FORMA AD+B

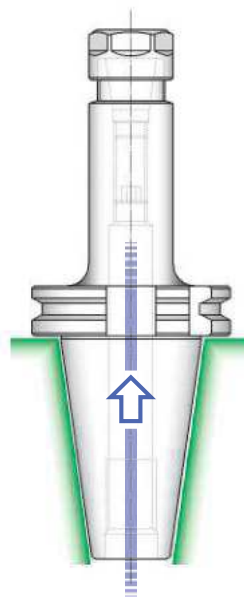

DOPPIO CONTATTO
FORMA AD

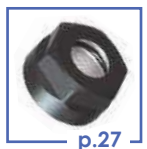

DIN 69871

ISO 7388-1

PORTAPINZA ER - GHIERA STANDARD

ER COLLET CHUCKS with STANDARD NUT

FORMA AD

FORMA AD+B (AD/AF)

Balanced	G 6,3
≤ H130	15.000 rpm
≥ H160	8.000 rpm



TIPO	FORMA AD	FORMA AD+B	DOPPIO CONTATTO	D	RANGE			
	Art.	Art.	Art.					
TC 30 - ER 16/H 55 TC 30 - ER 16/H 100	3442 3373	—	—	32	ER16 1÷12	4993	3698	0364
TC 30 - ER 20/H 55 TC 30 - ER 20/H 100	0138 3374	—	—	35	ER20 1÷15	4994	3699	0787
TC 30 - ER 25/H 55 TC 30 - ER 25/H 100	3342 3375	—	—	42	ER25 1÷20	4995	3669	0996
TC 30 - ER 32/H 60 TC 30 - ER 32/H 100	3343 3376	—	—	50	ER32 2÷25	4996	3670	0988
TC 40 - ER 11/H 70 TC 40 - ER 11/H 100 TC 40 - ER 11/H 130 TC 40 - ER 11/H 160	3336 3337 3338 3339	4725 4726 4727 4728	—	19	ER11 1÷8	1157 GE	2905 CE	5573
TC 40 - ER 16/H 70 TC 40 - ER 16/H 100 TC 40 - ER 16/H 130 TC 40 - ER 16/H 160 TC 40 - ER 16/H 200	3443 3444 3098 3445 3446	4700 4701 4754 4702 4755	10056 10057 — — —	32	ER16 1÷12	4993	3698	0364
TC 40 - ER 20/H 70 TC 40 - ER 20/H 100 TC 40 - ER 20/H 130 TC 40 - ER 20/H 160 TC 40 - ER 20/H 200	3344 0140 3099 3100 3104	4703 4704 4830 4705 4831	10061 10062 — — —	35	ER20 1÷15	4994	3699	0787
TC 40 - ER 25/H 70 TC 40 - ER 25/H 100 TC 40 - ER 25/H 130 TC 40 - ER 25/H 160 TC 40 - ER 25/H 200	3345 0141 0142 0146 3105	4706 4707 4708 4709 4832	10066 10067 10068 10069 —	42	ER25 1÷20	4995	3669	0996
TC 40 - ER 32/H 70 TC 40 - ER 32/H 100 TC 40 - ER 32/H 130 TC 40 - ER 32/H 160 TC 40 - ER 32/H 200	3346 3347 3101 3348 3102	4710 4711 4712 4713 4076	10071 10072 10073 10074 —	50	ER32 2÷25	4996	3670	0988
TC 40 - ER 40/H 70 TC 40 - ER 40/H 100 TC 40 - ER 40/H 130 TC 40 - ER 40/H 160 TC 40 - ER 40/H 200	3349 3350 3351 0153 3103	4714 4715 4716 4717 4718	10076 10077 — — —	63	ER40 3÷32	4997	3671	0821
TC 40 - ER 50/H 85	0154	4719	10081	78	ER50 6÷36	4998	3668	4055

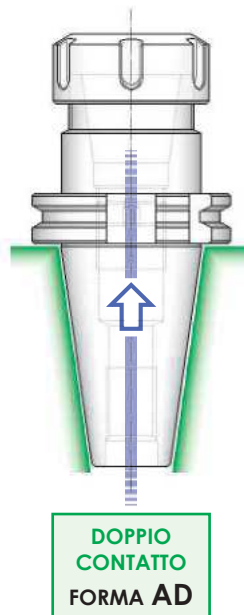
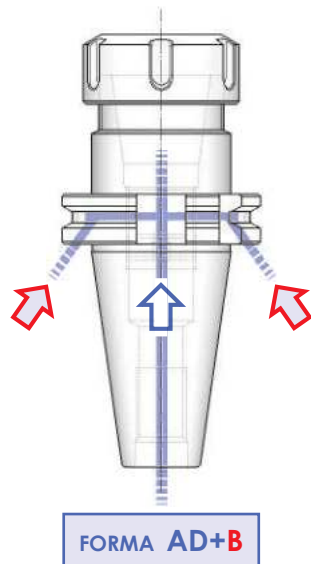
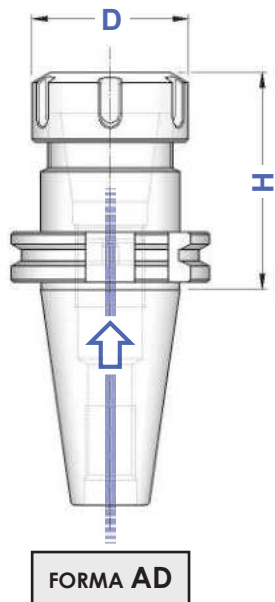

segue



➔ segue
continue

Balanced	G 6,3
≤ H130	15.000 rpm
≥ H160	8.000 rpm



TIPO	FORMA AD	FORMA AD+B	DOPPIO CONTATTO	D	RANGE			
	Art.	Art.	Art.					
TC 45 - ER 32/H 70	3353	—	—	50	ER32 2÷25	4996	3670	0988
TC 45 - ER 32/H 100	3106	—	—					
TC 45 - ER 32/H 130	3354	—	—					
TC 45 - ER 32/H 160	0184	—	—					
TC 45 - ER 40/H 80	3355	—	—	63	ER40 3÷32	4997	3671	0821
TC 50 - ER 16/H 100	3451	4731	—	32	ER16 1÷12	4993	3698	0364
TC 50 - ER 16/H 160	3452	4732	—					
TC 50 - ER 16/H 200	3453	4806	—					
TC 50 - ER 20/H 100	3110	4733	—	35	ER20 1÷15	4994	3699	0787
TC 50 - ER 20/H 160	3111	4734	—					
TC 50 - ER 20/H 200	3112	4807	—					
TC 50 - ER 25/H 70	3360	4735	10088	42	ER25 1÷20	4995	3669	0996
TC 50 - ER 25/H 100	0193	4736	10089					
TC 50 - ER 25/H 160	0199	4737	—					
TC 50 - ER 25/H 200	3372	4808	—					
TC 50 - ER 32/H 70	3900	4738	10092	50	ER32 2÷25	4996	3670	0988
TC 50 - ER 32/H 100	3361	4739	10093					
TC 50 - ER 32/H 130	3362	4740	10094					
TC 50 - ER 32/H 160	3363	4741	10095					
TC 50 - ER 32/H 200	3364	4742	10096					
TC 50 - ER 32/H 250	3382	4809	—					
TC 50 - ER 40/H 80	3901	4743	10098	63	ER40 3÷32	4997	3671	0821
TC 50 - ER 40/H 100	3365	4744	—					
TC 50 - ER 40/H 130	3366	4745	—					
TC 50 - ER 40/H 160	3367	4746	—					
TC 50 - ER 40/H 200	3368	4747	—					
TC 50 - ER 50/H 100	3369	4810	—					
TC 50 - ER 50/H 160	8044	8045	—					

**KIT CON SERIE RIDOTTA
DI PINZE ER, MANDRINO "FORMA AD" E CHIAVE**

EQUIPMENT CASES WITH REDUCED SET OF ER COLLETS,
"FORM AD" COLLET CHUCK AND WRENCH



**FORMA
AD**



TIPO	Art.			
KIT Rid TC 40/H 70 - ER 25	7772	3345	7022	3669
KIT Rid TC 40/H 70 - ER 32	7773	3346	7023	3670
KIT Rid TC 40/H 70 - ER 40	7774	3349	7024	3671
KIT Rid TC 50/H 70 - ER 32	7775	3900	7023	3670
KIT Rid TC 50/H 80 - ER 40	7776	3901	7024	3671

**KIT CON SERIE COMPLETA
DI PINZE ER, MANDRINO "FORMA AD" E CHIAVE**

EQUIPMENT CASES WITH COMPLETE SET OF ER COLLETS,
"FORM AD" COLLET CHUCK AND WRENCH



**FORMA
AD**



TIPO	Art.			
KIT TC 40/H 70 - ER25	7779	3345	7022	3669
KIT TC 40/H 70 - ER32	7780	3346	7023	3670
KIT TC 40/H 70 - ER40	7781	3349	7024	3671
KIT TC 50/H 70 - ER32	7782	3900	7023	3670
KIT TC 50/H 80 - ER40	7783	3901	7024	3671

DIN 69871

ISO 7388-1

MANDRINI PER PINZE EOC DIN 6388



DIN 6388 COLLET CHUCKS

FORMA AD+B (AD/AF)

Balanced G 6,3
12.000 rpm

FORMA AD+B



TIPO	Art.	D	RANGE			
TC 40 - EOC 16/H 70 TC 40 - EOC 16/H 100 TC 40 - EOC 16/H 130	8693 8694 8695	43	EOC 16 2÷16	4067	2883	0768
TC 40 - EOC 25/H 70 TC 40 - EOC 25/H 100 TC 40 - EOC 25/H 130	8696 8697 8698	60	EOC 25 2÷25	4068	2909	0769
TC 40 - EOC 32/H 80	8699	72	EOC 32 3÷32	4069	2910	0770
TC 50 - EOC 16/H 70 TC 50 - EOC 16/H 100	8700 8701	43	EOC 16 2÷16	4067	2883	0768
TC 50 - EOC 25/H 70 TC 50 - EOC 25/H 100 TC 50 - EOC 25/H 130	8702 8703 8704	60	EOC 25 2÷25	4068	2909	0769
TC 50 - EOC 32/H 80 TC 50 - EOC 32/H 130	8705 8706	72	EOC 32 3÷32	4069	2910	0770

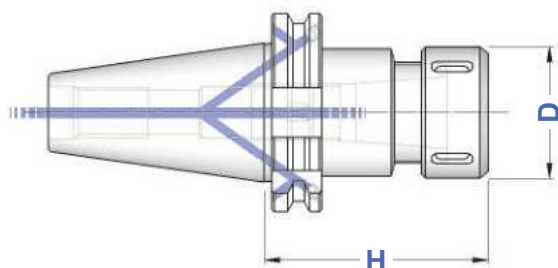

**Pinze, ghiera e chiavi
EOC - DIN 6388
si trovano da pagina 268**

*Collets, nuts and wrenches
EOC - DIN 6388 type
you can find from page 268*



SERIE RIDOTTA DI PINZE EOC

REDUCED SET OF EOC COLLETS

TIPO	Diametri	n° pinze	Art.	Art.
EOC 16 - Ridotta	Ø 4 - 6 - 8 - 10 - 12 - 16	6	7010	7016
EOC 25 - Ridotta	Ø 6 - 8 - 10 - 12 - 16 - 20 - 25	7	7011	7017
EOC 32 - Ridotta	Ø 6 - 8 - 10 - 12 - 16 - 20 - 25 - 32	8	7012	7018

**IN CONFEZIONI
SINGOLE**
IN SINGLE PACKS



IN VALIGETTA
IN CASE



SERIE COMPLETA DI PINZE EOC

COMPLETE SET OF EOC COLLETS

TIPO	Diametri	n° pinze	Art.	Art.
EOC 16 - Completa	da Ø 2 a Ø 16	15	7013	7019
EOC 25 - Completa	da Ø 2 a Ø 25	24	7014	7020
EOC 32 - Completa	da Ø 4 a Ø 32	29	7015	7021

**IN CONFEZIONI
SINGOLE**
IN SINGLE PACKS



IN VALIGETTA
IN CASE



DIN 69871 ISO 7388-1	MANDRINI A FORTE SERRAGGIO HIGH GRIP CHUCKS	FORMA AD
		FORMA AD+B (AD/AF)

Balanced G 6,3
12.000 rpm



TIPO	FORMA AD	FORMA AD+B	DOPPIO CONTATTO	E	D	Art.
	Art.	Art.	Art.			
TC 40 - PC 12/H 65	9624	9630	10311	34	12	0804
TC 40 - PC 12/H 120	9625	9631	10312			
TC 40 - PC 16/H 65	9626	9632	10313	42	16	0805
TC 40 - PC 16/H 120	9627	9633	10314			
TC 40 - PC 20/H 90	5110	5222	10315	54	20	0809
TC 40 - PC 20/H 105	3241	—	10316			
TC 40 - PC 20/H 120	9628	9634	10317	50		
TC 40 - PC 32/H 95	—	5223	10318	63	32	0810
TC 40 - PC 32/H 105	3242	—	10319	72		
TC 40 - PC 32/H 135	5103	9635	—	63		
TC 50 - PC 20/H 85	—	5225	10320	50	20	0809
TC 50 - PC 20/H 105	3243	9636	—	54		
TC 50 - PC 20/H 135	—	9637	10321	50		
TC 50 - PC 32/H 90	—	5226	10322	63	32	0810
TC 50 - PC 32/H 105	3244	5227	—	72		
TC 50 - PC 32/H 135	5106	9638	—	—		

Forniti completi dell'apposita chiave
Supplied complete with suitable wrench

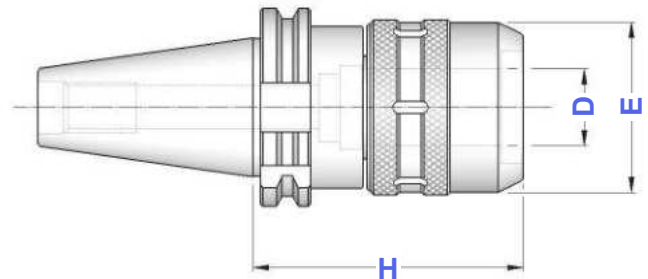

Pinze precisione standard pag. 270
Pinze alta precisione pag. 271
Standard precision collets page 270
High precision collets page 271

**KIT CON MANDRINO
CHIAVE E PINZE**
EQUIPMENT CASES WITH COLLET CHUCK
WRENCH AND COLLETS

TIPO	Art.	FORMA AD			
KIT TC 40 - PC 20 / H 90	7543	5110	3695	2900	0809 ø 6 - 8 - 10 - 12 - 16
KIT TC 40 - PC 20 / H 105	7704	3241	3695	2910	0810 ø 6 - 8 - 10 - 12 - 16 - 20 - 25
KIT TC 40 - PC 32 / H 105	7707	3242	3695	2910	0810 ø 6 - 8 - 10 - 12 - 16 - 20 - 25
KIT TC 50 - PC 20 / H 105	7708	3243	3695	2900	0809 ø 6 - 8 - 10 - 12 - 16
KIT TC 50 - PC 32 / H 105	7711	3244	3695	2910	0810 ø 6 - 8 - 10 - 12 - 16 - 20 - 25



DIN 69871

ISO 7388-1

MANDRINI A SERRAGGIO IDRAULICO

HYDRAULIC CHUCKS

FORMA AD

FORMA AD+B (AD/AF)

Balanced G 2,5

25.000 rpm

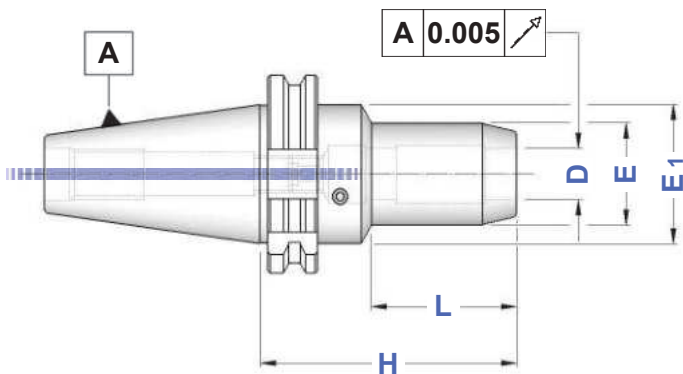

FORMA AD

TIPO	Art.	D	H	E	E1	L
TC 40 - HYDRO 6	5151	6	80,5	28	50	44
TC 40 - HYDRO 8	5152	8	80,5	30	50	44
TC 40 - HYDRO 10	5153	10	80,5	32	50	44
TC 40 - HYDRO 12	5154	12	80,5	34	50	44
TC 40 - HYDRO 16	5155	16	80,5	38	50	48
TC 40 - HYDRO 20	5156	20	80,5	43	50	48
TC 40 - HYDRO 25	5157	25	80,5	57	66	26
TC 40 - HYDRO 32	5158	32	80,5	63	80	26
TC 50 - HYDRO 6	8995	6	90,0	28	50	44
TC 50 - HYDRO 8	8996	8	90,0	30	50	44
TC 50 - HYDRO 10	8997	10	90,0	32	50	44
TC 50 - HYDRO 12	8998	12	90,0	34	50	44
TC 50 - HYDRO 16	8999	16	90,0	38	50	48
TC 50 - HYDRO 20	9001	20	90,0	43	50	48
TC 50 - HYDRO 25	9002	25	105,0	57	-	86
TC 50 - HYDRO 32	9003	32	115,0	63	-	96

Applicazioni: bloccaggio ad alta precisione di utensili a gambo cilindrico in tolleranza h6

Attenzione: non azionare il sistema idraulico se l'utensile non è inserito completamente nel mandrino

Applications: high precision locking of cylindrical shank tools with shank tolerance h6

Warning: do not start Hydraulic System if tool is not completely fitted into the spindle



TIPO COMPATTO

COMPACT TYPE

FORMA AD **FORMA AD+B**

TIPO	Art.	Art.	D	H	E1
TC 40 - HYDRO 20 C	5104	5150	20	64,5	49,5
TC 50 - HYDRO 32 C	5105	5160	32	81,0	72,0

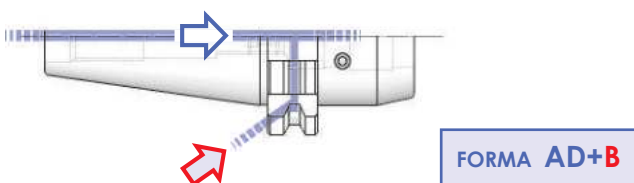
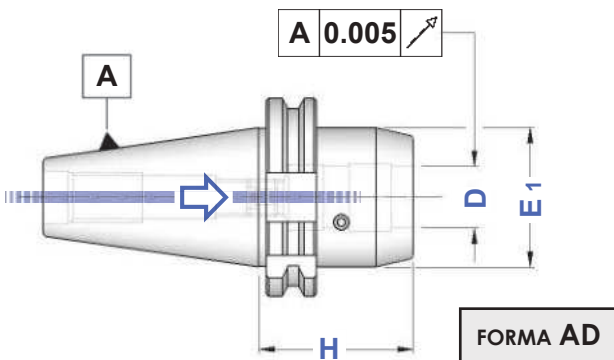

Pinze per Mandrini Idraulici pag. 272

Watertight collets on page 272



DIN 69871

ISO 7388-1

BARRE A STELO TENERO

BLANK BARS



TIPO	Art.	D	H
TC 40 - D. 40 ST	4355	40	160
TC 40 - D. 50 ST	4356	50	200
TC 40 - D. 63 ST	4357	63	250
TC 50 - D. 40 ST	4362	40	160
TC 50 - D. 63 ST	4364	63	250
TC 50 - D. 80 ST	4365	80	300

DIN 69871

ISO 7388-1

BARRE DI CONTROLLO

TEST ARBORS



Fig. 1

TIPO	Art.	Fig.	H	D
TC 40 - D. 40 SC	2225	1	300	40
TC 50 - D. 50 SC	2229	1	350	50

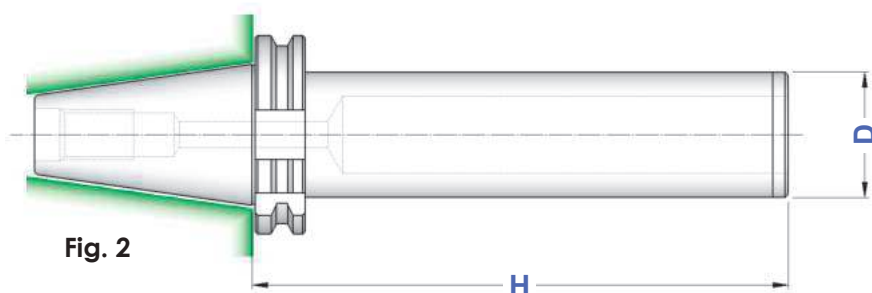

Fig. 2

**DOPPIO
CONTATTO**

TIPO	Art.	Fig.	H	D
TC 40 - D.40 SC 2	10309	2	300	40
TC 50 - D.50 SC 2	10310	2	350	50

Dati costruttivi

- Costruite in acciaio da cementazione certificato
- Cementate con profondità 0,6 - 0,8 mm
- Temprate, rinvenute, brunite
- Durezza HRC 58 ± 2, resistenza 800-1000 N/mm²
- Rotondità in rotazione 0,005
- Cilindricità 0,003

Constructive Features

- Manufactured with hardening steel
- Hardened 0,6 - 0,8 mm depth
- Hardened, tempered, burnished
- Hardness HRC 58 ± 2, strenght 800-1000 N/mm²
- Runout accuracy 0,005
- Cylindricity 0,003



**Fornite con
apposito contenitore**

Supplied with
suitable case

DIN 69871

ISO 7388-1

MANDRINI PER PUNTE AD INSERTI INDEXABLE DRILL HOLDERS

FORMA AD

Balanced G 6,3
12.000 rpm



FORMA AD

TIPO	Art.	D	H	E	L	
TC 40 - D. 16 P	8677	16	65	36	54	0403
TC 40 - D. 20 P	8678	20	65	40	54	0403
TC 40 - D. 25 P	8679	25	70	45	59	0417
TC 40 - D. 32 P	8680	32	70	52	63	0417
TC 50 - D. 16 P	8681	16	70	36	54	0403
TC 50 - D. 20 P	8682	20	70	40	54	0403
TC 50 - D. 25 P	8683	25	70	45	59	0417
TC 50 - D. 32 P	8684	32	70	52	63	0417
TC 50 - D. 40 P	8685	40	80	60	73	0493

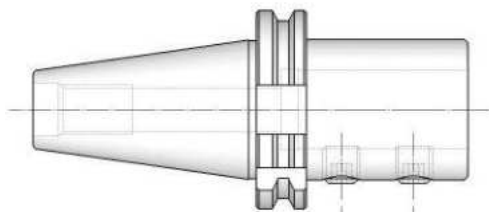
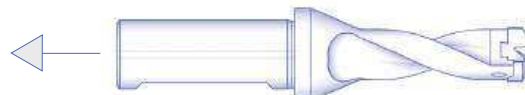
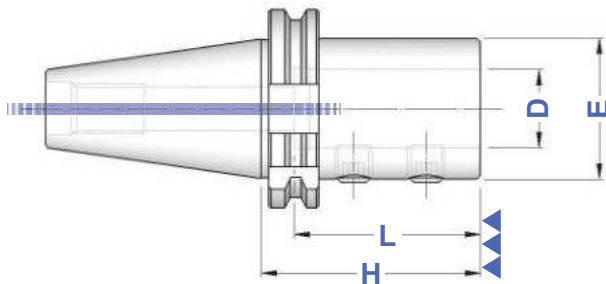

n.2 grani di bloccaggio
two locking screws



p.259



Tamponi Pulitori pag. 243
Taper Cleaners page 243



Codoli di Aggancio pag. 221

Pull Studs
page 221



Smontaconi Orientabili pag. 240
Orientable Tightening Fixtures page 240

DIN 69871

ISO 7388-1

PORTAFRESE WELDON TIPO EXTRACORTO

SHORT TYPE END MILL HOLDERS

FORMA AD

FORMA AD+B (AD/AF)

Balanced G 6,3

12.000 rpm





TIPO	FORMA AD	FORMA AD+B	D	H	E	Fig.	 	
	Art.	Art.					G1	G2
TC 40 - WE 12/H 35	3079	8341	12	35	44	1	4973	-
TC 40 - WE 16/H 35	3080	2231	16	35	44	1	0068	-
TC 40 - WE 20/H 35	3081	2242	20	35	44	1	0070	-
TC 40 - WE 25/H 35	3082	—	25	35	44	1	0076	-
TC 40 - WE 25/H 60	3015	4641	25	60	49	2	0076	0076
TC 40 - WE 32/H 40	3083	—	32	40	44	1	0074	-
TC 40 - WE 32/H 70	4640	4643	32	70	72	2	0082	4977
TC 50 - WE 16/H 35	3086	2234	16	35	70	1	4974	-
TC 50 - WE 20/H 35	3087	2237	20	35	70	1	4975	-
TC 50 - WE 25/H 35	3088	2251	25	35	70	1	4976	-
TC 50 - WE 32/H 35	3089	2252	32	35	80	1	4977	-
TC 50 - WE 40/H 35	3136	8345	40	35	80	1	0259	-

Figura 1

1 grano di bloccaggio
single locking screw



Figura 2

2 grani di bloccaggio
two locking screws

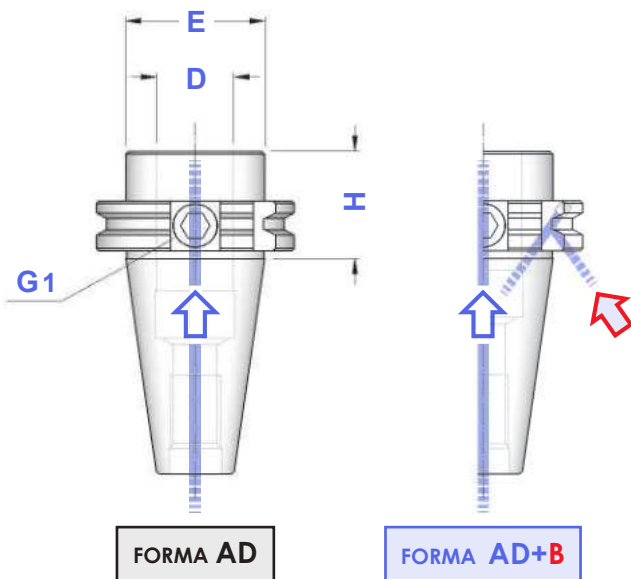
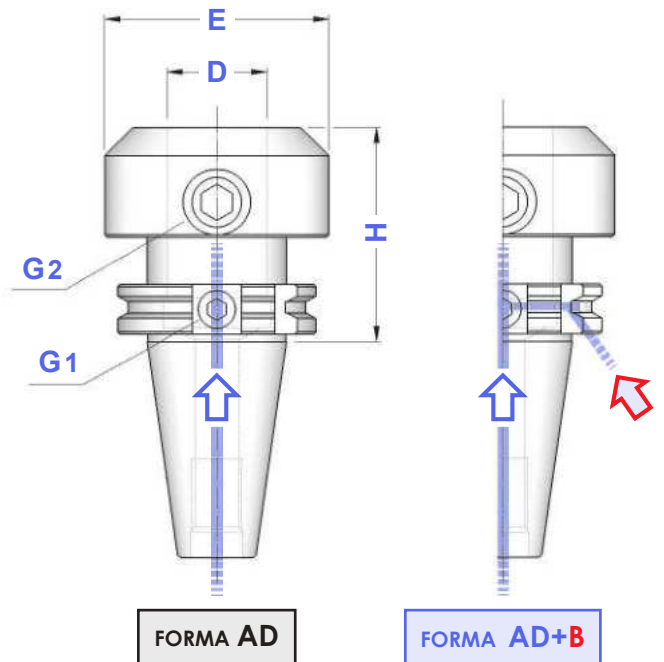

DIN 69871

ISO 7388-1

PORTAFRESE WELDON

END MILL HOLDERS FOR DIN 1835-B SHANKS

FORMA AD

FORMA AD+B (AD/AF)

Balanced	G 6,3
≤ H130	12.000 rpm
≥ H160	8.000 rpm



WE6 ÷ WE20
1 grano
1 screw



WE25 ÷ WE50
2 grani
2 screws

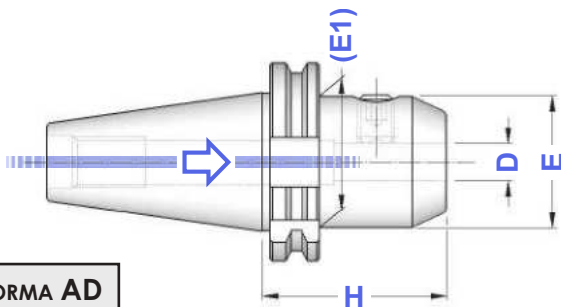

FORMA AD

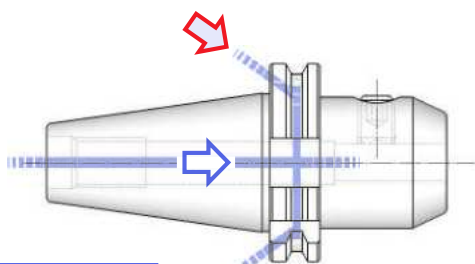

FORMA AD+B

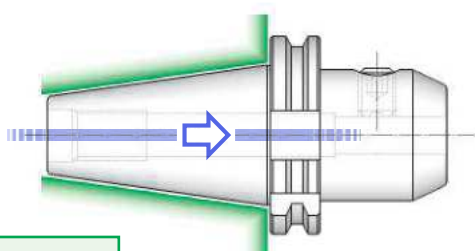

**DOPPIO CONTATTO
FORMA AD**

TIPO	FORMA AD	FORMA AD+B	DOPPIO CONTATTO	D	H	E	
	Art.	Art.	Art.				
TC 30 - WE 6/H 45	3707	—	—	6	45	25	4970
TC 30 - WE 8/H 45	3708	—	—	8	45	28	4971
TC 30 - WE 10/H 50	3709	—	—	10	50	35	4972
TC 30 - WE 12/H 50	3710	—	—	12	50	42	4973
TC 30 - WE 16/H 70	3711	—	—	16	70	48	4974
TC 30 - WE 20/H 70	3712	—	—	20	70	52	4975
TC 40 - WE 6/H 50	3714	4761	10121	6	50	25	4970
TC 40 - WE 6/H100	5001	5028	10122		100		
TC 40 - WE 6/H130	5400	5416	—		130		
TC 40 - WE 6/H160	5519	5551	—		160		
TC 40 - WE 6/H200	4029	4144	—		200		
TC 40 - WE 8/H 50	3715	4762	10126	8	50	28	4971
TC 40 - WE 8/H100	5002	5029	10127		100		
TC 40 - WE 8/H130	5401	5417	—		130		
TC 40 - WE 8/H160	5520	5552	—		160		
TC 40 - WE 8/H200	4030	4146	—		200		
TC 40 - WE 10/H 50	3716	4763	10131	10	50	35	4972
TC 40 - WE 10/H100	5003	5030	10132		100		
TC 40 - WE 10/H130	5402	5418	—		130		
TC 40 - WE 10/H160	5521	5553	—		160		
TC 40 - WE 10/H200	4031	4148	—		200		
TC 40 - WE 12/H 50	3717	4764	10136	12	50	42	4973
TC 40 - WE 12/H100	5004	5031	10137		100		
TC 40 - WE 12/H130	5403	5419	—		130		
TC 40 - WE 12/H160	5524	5554	—		160		
TC 40 - WE 12/H200	4032	4150	—		200		
TC 40 - WE 14/H 50	3594	4765	10141	14	50	44	4973
TC 40 - WE 14/H100	5005	5032	—		100		
TC 40 - WE 14/H130	4033	4155	—		130		
TC 40 - WE 14/H160	4034	4157	—		160		
TC 40 - WE 14/H200	4035	4158	—		200		
TC 40 - WE 16/H 63	3718	4766	10146	16	63	48	4974
TC 40 - WE 16/H100	5006	5033	10147		100		
TC 40 - WE 16/H130	5404	5420	—		130		
TC 40 - WE 16/H160	5007	5035	—		160		
TC 40 - WE 16/H200	4036	4159	—		200		
TC 40 - WE 18/H 63	3595	4767	10151	18	63	50	4974
TC 40 - WE 18/H100	5008	5036	—		100		
TC 40 - WE 18/H130	4037	4160	—		130		
TC 40 - WE 18/H160	4038	4162	—		160		
TC 40 - WE 18/H200	4039	4163	—		200		
TC 40 - WE 20/H 63	3719	4768	10156	20	63	50	4975
TC 40 - WE 20/H100	5010	5038	10157		100		
TC 40 - WE 20/H130	5011	5039	—		130		
TC 40 - WE 20/H160	5012	5040	—		160		
TC 40 - WE 20/H200	4043	4164	—		200		
TC 40 - WE 25/H100	3720	4769	10161	25	100	65	4976
TC 40 - WE 25/H130	5013	5041	—		130		
TC 40 - WE 25/H160	5014	5042	—		160		
TC 40 - WE 25/H200	4044	4166	—		200		
TC 40 - WE 32/H100	3721	4770	10165	32	100	72	4977
TC 40 - WE 32/H130	5015	5043	—		130		
TC 40 - WE 32/H160	5016	5044	—		160		
TC 40 - WE 32/H200	4045	4168	—		200		
TC 40 - WE 40/H115	4457	4771	10169	40	115	80	4977

segue

➔ segue
continue

Balanced G 6,3
8.000 rpm



WE6 ÷ WE20
1 grano
1 screw



WE25 ÷ WE50
2 grani
2 screws

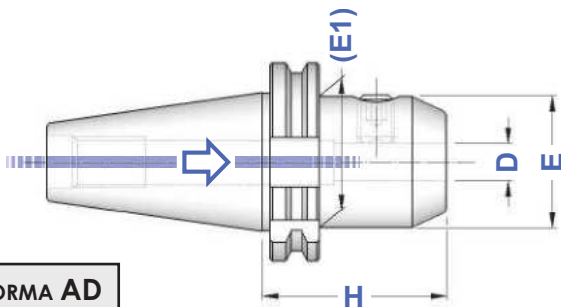

FORMA AD

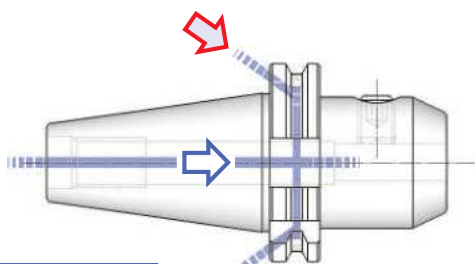

FORMA AD+B

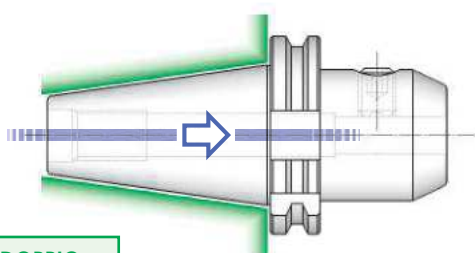

DOPPIO
CONTATTO
FORMA AD

TIPO	FORMA	FORMA	DOPPIO	D	H	E	
	AD	AD+B	CONTATTO				
	Art.	Art.	Art.				
TC 45 - WE 6/H 63	3722	—	—	6	63	25	4970
TC 45 - WE 8/H 63	3723	—	—	8	63	28	4971
TC 45 - WE 10/H 63	3724	—	—	10	63	35	4972
TC 45 - WE 12/H 63	3725	—	—	12	63	42	4973
TC 45 - WE 16/H 63	3726	—	—	16	63	48	4974
TC 45 - WE 20/H 63	3727	—	—	20	63	52	4975
TC 45 - WE 25/H 100	3728	—	—	25	100	65	4976
TC 45 - WE 32/H 100	3729	—	—	32	100	72	4977
TC 45 - WE 40/H 100	4515	—	—	40	100	80	4977
TC 50 - WE 6/H 63	3730	4783	10170	6	63	25	4970
TC 50 - WE 6/H 100	5017	5045	—		100		
TC 50 - WE 6/H 130	5405	5426	—		130		
TC 50 - WE 6/H 160	5525	5555	—		160		
TC 50 - WE 6/H 200	4123	4173	—		200		
TC 50 - WE 8/H 63	3731	4784	10175	8	63	28	4971
TC 50 - WE 8/H 100	5018	5046	—		100		
TC 50 - WE 8/H 130	5406	5427	—		130		
TC 50 - WE 8/H 160	5526	5556	—		160		
TC 50 - WE 8/H 200	4125	4175	—		200		
TC 50 - WE 10/H 63	3732	4785	10180	10	63	35	4972
TC 50 - WE 10/H 100	5019	5047	—		100		
TC 50 - WE 10/H 130	5407	5428	—		130		
TC 50 - WE 10/H 160	5527	5558	—		160		
TC 50 - WE 10/H 200	4128	4177	—		200		
TC 50 - WE 12/H 63	3733	4786	10185	12	63	42	4973
TC 50 - WE 12/H 100	5528	5559	—		100		
TC 50 - WE 12/H 130	5408	5429	—		130		
TC 50 - WE 12/H 160	5020	5048	—		160		
TC 50 - WE 12/H 200	4129	4179	—		200		
TC 50 - WE 14/H 63	4516	4787	10190	14	63	44	4973
TC 50 - WE 14/H 100	5529	5560	—		100		
TC 50 - WE 14/H 130	4130	4182	—		130		
TC 50 - WE 14/H 160	4132	4183	—		160		
TC 50 - WE 14/H 200	4134	4204	—		200		
TC 50 - WE 16/H 63	3734	4788	10195	16	63	48	4974
TC 50 - WE 16/H 100	5534	5561	—		100		
TC 50 - WE 16/H 130	5409	5430	—		130		
TC 50 - WE 16/H 160	5022	5050	—		160		
TC 50 - WE 16/H 200	4136	4206	—		200		
TC 50 - WE 18/H 63	4517	4789	10200	18	63	50	4974
TC 50 - WE 18/H 100	5535	5562	—		100		
TC 50 - WE 18/H 130	4137	4213	—		130		
TC 50 - WE 18/H 160	4138	4215	—		160		
TC 50 - WE 18/H 200	4139	4236	—		200		
TC 50 - WE 20/H 63	3735	4790	10205	20	63	52	4975
TC 50 - WE 20/H 100	5536	5563	—		100		
TC 50 - WE 20/H 130	5410	5431	—		130		
TC 50 - WE 20/H 160	5024	5052	—		160		
TC 50 - WE 20/H 200	4140	4242	—		200		
TC 50 - WE 25/H 80	3736	4791	10210	25	80	65	4976
TC 50 - WE 25/H 100	5413	5051	—		100		
TC 50 - WE 25/H 130	5414	5432	—		130		
TC 50 - WE 25/H 160	5025	5054	—		160		
TC 50 - WE 25/H 200	4141	4244	—		200		
TC 50 - WE 32/H 100	3737	4792	10215	32	100	72	4977
TC 50 - WE 32/H 130	5415	5433	—		130		
TC 50 - WE 32/H 160	5026	5055	—		160		
TC 50 - WE 32/H 200	4142	4245	—		200		
TC 50 - WE 40/H 120	3738	4793	10219	40	120	80	4977
TC 50 - WE 40/H 160	5027	5056	—		160		
TC 50 - WE 50/H 120	3739	4247	—	50	120	100	4978

DIN 69871

ISO 7388-1

PORTAFRESE WELDON CON CANALI DI REFRIGERAZIONE

END MILL HOLDERS with COOLANT CHANNELS for DIN 1835B SHANKS

FORMA AD+B (AD/AF)

Balanced G 6,3
12.000 rpm



WEC 6 ÷ WEC 20
1 grano
1 screw



WEC 25 ÷ WEC 40
2 grani
2 screws

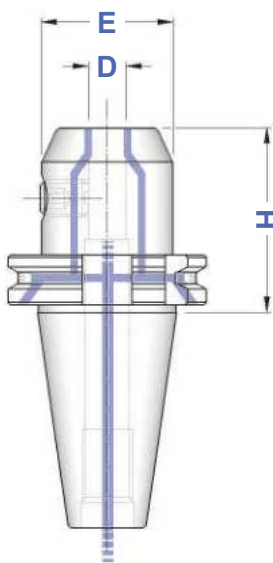

**FORMA
AD+B**



TIPO	Art.	D	H	E	
TC 40 - WEC 6/H 50	7850	6	50	25	4970
TC 40 - WEC 8/H 50	7851	8	50	28	4971
TC 40 - WEC 10/H 50	7852	10	50	35	4972
TC 40 - WEC 12/H 50	7853	12	50	42	4973
TC 40 - WEC 14/H 50	7854	14	50	44	4973
TC 40 - WEC 16/H 63	7855	16	63	48	4974
TC 40 - WEC 18/H 63	7856	18	63	50	4974
TC 40 - WEC 20/H 63	7857	20	63	52	4975
TC 40 - WEC 25/H 100	7858	25	100	65	4976
TC 40 - WEC 32/H 100	7859	32	100	72	4977
TC 40 - WEC 40/H 115	7860	40	115	80	4977
TC 50 - WEC 6/H 63	7861	6	63	25	4970
TC 50 - WEC 8/H 63	7862	8	63	28	4971
TC 50 - WEC 10/H 63	7863	10	63	35	4972
TC 50 - WEC 12/H 63	7864	12	63	42	4973
TC 50 - WEC 14/H 63	7865	14	63	44	4973
TC 50 - WEC 16/H 63	7866	16	63	48	4974
TC 50 - WEC 18/H 63	7867	18	63	50	4974
TC 50 - WEC 20/H 63	7868	20	63	52	4975
TC 50 - WEC 25/H 80	7869	25	80	65	4976
TC 50 - WEC 32/H 100	7870	32	100	72	4977
TC 50 - WEC 40/H 120	7871	40	120	80	4977

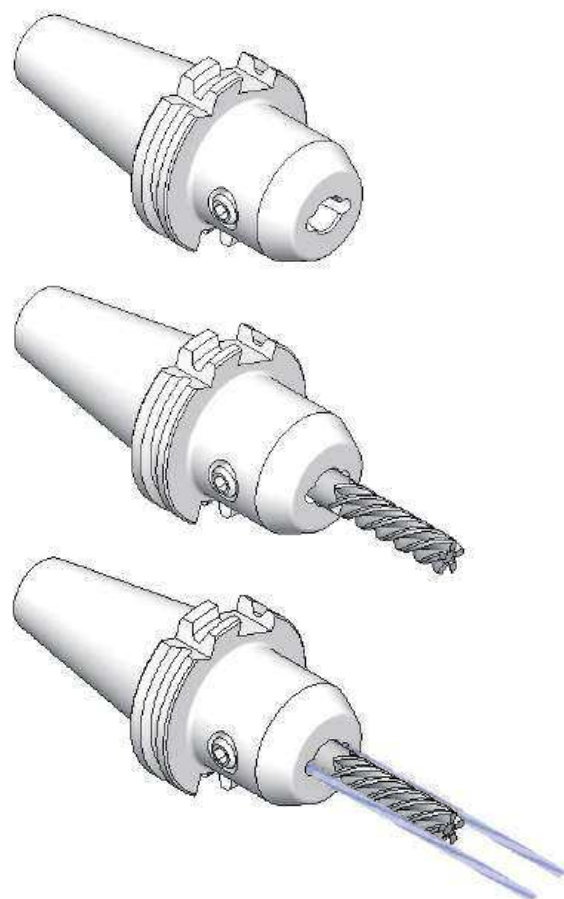

DIN 69871

ISO 7388-1

MANDRINI PER UTENSILI ATTACCO WHISTLE NOTCH

END MILL HOLDERS FOR DIN 1835-E SHANKS

FORMA AD+B (AD/AF)

Balanced G 6,3
12.000 rpm



WN6 ÷ WN20
1 grano
1 screw



WN25 ÷ WN40
2 grani
2 screws

FORMA AD+B



TIPO	Art.	D	H	E	
TC 40 - WN 6/ H 50	4795	6	50	25	4970
TC 40 - WN 8/ H 50	4796	8	50	28	4971
TC 40 - WN 10/ H 50	4797	10	50	35	4972
TC 40 - WN 12/ H 50	4798	12	50	42	4973
TC 40 - WN 14/ H 50	4799	14	50	44	4973
TC 40 - WN 16/ H 63	4800	16	63	48	4974
TC 40 - WN 18/ H 63	4801	18	63	50	4974
TC 40 - WN 20/ H 63	4802	20	63	52	4975
TC 40 - WN 25/ H 100	4803	25	100	65	4976
TC 40 - WN 32/ H 100	4804	32	100	72	4977
TC 40 - WN 40/ H 115	4805	40	115	80	4977
TC 50 - WN 6/ H 63	4815	6	63	25	4970
TC 50 - WN 8/ H 63	4816	8	63	28	4971
TC 50 - WN 10/ H 63	4817	10	63	35	4972
TC 50 - WN 12/ H 63	4818	12	63	42	4973
TC 50 - WN 14/ H 63	4819	14	63	44	4973
TC 50 - WN 16/ H 63	4820	16	63	48	4974
TC 50 - WN 18/ H 63	4821	18	63	50	4974
TC 50 - WN 20/ H 63	4822	20	63	52	4975
TC 50 - WN 25/ H 80	4823	25	80	65	4976
TC 50 - WN 32/ H 100	4824	32	100	72	4977
TC 50 - WN 40/ H 120	4825	40	120	80	4977

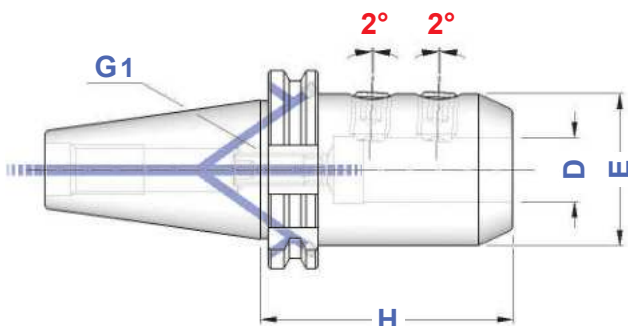
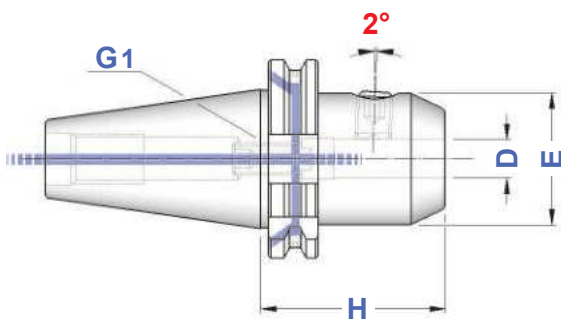

2° ⇨ WHISTLE NOTCH

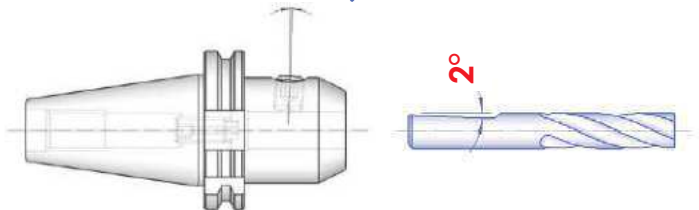

GRANO di PRESETTAGGIO con foro passante (G1)
PPRESETTING SCREW through hole (G1)

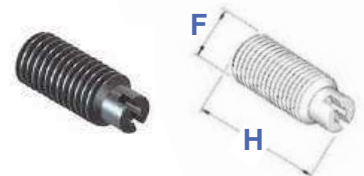

Art.	F x H	Passo
0233	M 5 x 16	0,8
0235	M 6 x 16	1
0238	M 8 x 20	1,25
0240	M 10 x 25	1,5
0245	M 12 x 30	1,75
1226	M 16 x 20	2
0212	M 20 x 20	2,5
0247	M 20 x 30	2,5

DIN 69871 ISO 7388-1	RIDUZIONI A CONO MORSE PER PUNTE MT ADAPTERS FOR TWIST DRILLS	FORMA AD
--------------------------------	---	-----------------

Balanced G 6,3
8.000 rpm

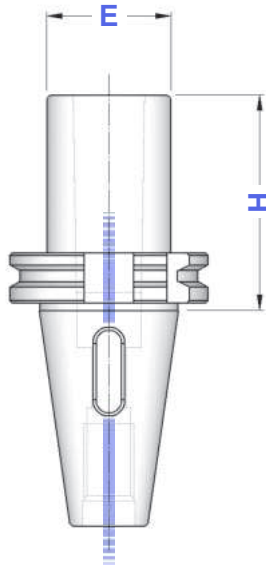

FORMA AD

TIPO	Art.	CM	H	E
TC 30 - CM 1 PUNTE	3600	1	55	25
TC 30 - CM 2 PUNTE	3631	2	60	32
TC 30 - CM 3 PUNTE	3632	3	90	40
TC 40 - CM 1 PUNTE	3601	1	50	25
TC 40 - CM 2 PUNTE	3602	2	60	32
TC 40 - CM 3 PUNTE	3635	3	75	40
TC 40 - CM 4 PUNTE	3636	4	95	48
TC 50 - CM 1 PUNTE	3603	1	45	25
TC 50 - CM 2 PUNTE	3604	2	60	32
TC 50 - CM 3 PUNTE	3605	3	65	40
TC 50 - CM 4 PUNTE	3645	4	95	48
TC 50 - CM 5 PUNTE	3646	5	105	63



DIN 69871 ISO 7388-1	RIDUZIONI A CONO MORSE PER FRESE MT ADAPTERS FOR MILLING CUTTERS	FORMA A
--------------------------------	--	----------------

Balanced G 6,3
8.000 rpm



FORMA A

TIPO	Art.	CM	H	E		
TC 30 - CM 2 FRESE	3892	2	60	32	7422	4569
TC 30 - CM 3 FRESE	3893	3	80	40	7423	4570
TC 40 - CM 2 FRESE	3681	2	50	32	7422	4569
TC 40 - CM 3 FRESE	3894	3	70	40	7423	4570
TC 40 - CM 4 FRESE	3895	4	95	48	7424	4571
TC 45 - CM 4 FRESE	3896	4	110	48	7424	4571
TC 50 - CM 2 FRESE	3666	2	50	32	7422	4569
TC 50 - CM 3 FRESE	3897	3	65	40	7423	4570
TC 50 - CM 4 FRESE	3898	4	95	48	7424	4571
TC 50 - CM 5 FRESE	3899	5	120	63	7425	4572

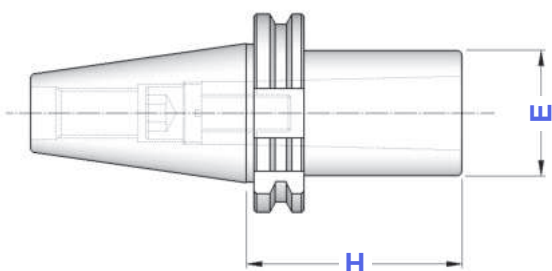

DIN 69871 ISO 7388-1	RIDUZIONI A CONO MORSE PUNTE + FRESE COMBINATE COMBI MT ADAPTERS: TWIST DRILLS + MILLING CUTTERS	FORMA A

Balanced G 6,3
8.000 rpm

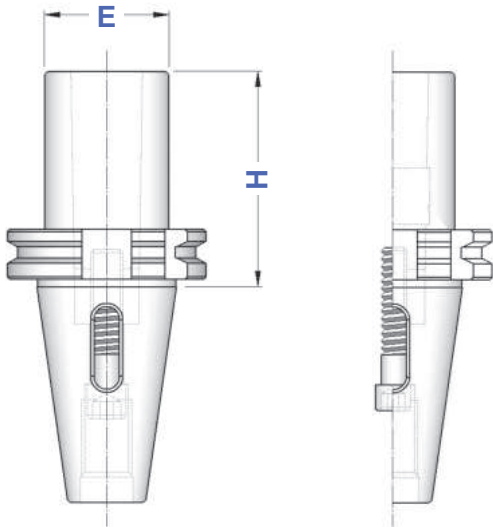

COMBINATE PUNTE + FRESE
COMBI TWIST DRILL + MILLING CUTTERS

PUNTE + FRESE

TIPO	Art.	CM	H	E
TC 40 - CM 1 P+F	3633	1	50	25
TC 40 - CM 2 P+F	3634	2	60	32
TC 40 - CM 3 P+F	3607	3	75	40
TC 45 - CM 1 P+F	3637	1	50	25
TC 45 - CM 2 P+F	3638	2	60	32
TC 45 - CM 3 P+F	3639	3	80	40
TC 45 - CM 4 P+F	3641	4	100	48
TC 50 - CM 1 P+F	3642	1	45	25
TC 50 - CM 2 P+F	3643	2	60	32
TC 50 - CM 3 P+F	3644	3	65	40
TC 50 - CM 4 P+F	3682	4	95	48



DIN 69871 ISO 7388-1	RIDUZIONI A CONO MORSE PER PUNTE E PUNTE + FRESE TIPO PROLUNGATO EXTENDED MT ADAPTERS: TWIST DRILLS, TWIST DRILLS + MILLING CUTTERS	FORMA A

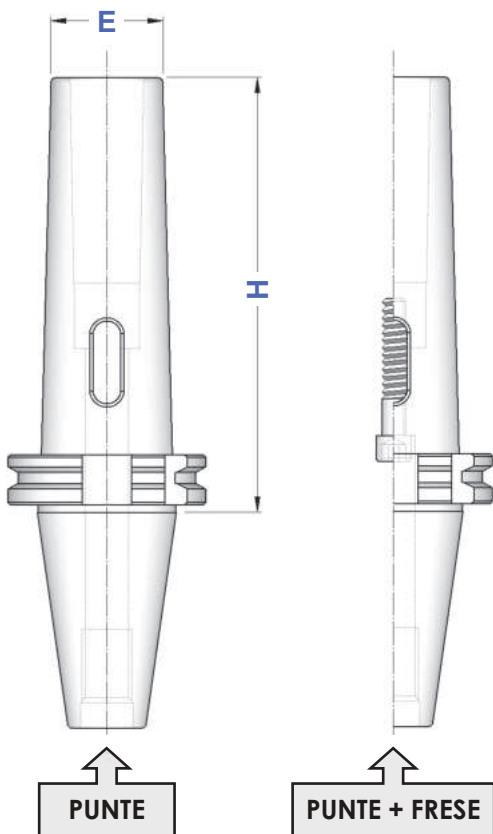

PUNTE

PUNTE + FRESE

PUNTE
PUNTE + FRESE

TIPO	Art.	Art.	CM	H	E
TC 40 - CM 1	3778	4238	1	120	18
TC 40 - CM 2	3779	4239	2	120	25
TC 40 - CM 3	3780	4240	3	140	33
TC 40 - CM 4	4241	—	4	165	48
TC 45 - CM 3	—	3686	3	140	33
TC 45 - CM 4	—	3687	4	160	40
TC 50 - CM 1	3745	4248	1	120	18
TC 50 - CM 2	3746	4249	2	140	25
TC 50 - CM 3	3747	4250	3	150	33
TC 50 - CM 4	3748	4251	4	180	40
TC 50 - CM 5	3749	—	5	220	55



DIN 69871

ISO 7388-1

PORTAFRESE FISSI FACE MILL HOLDERS

FORMA A

FORMA AD+B (AD/AF)

Balanced G 6,3
8.000 rpm

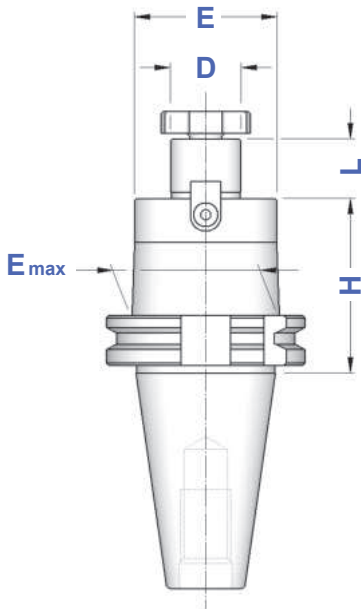

FORMA A

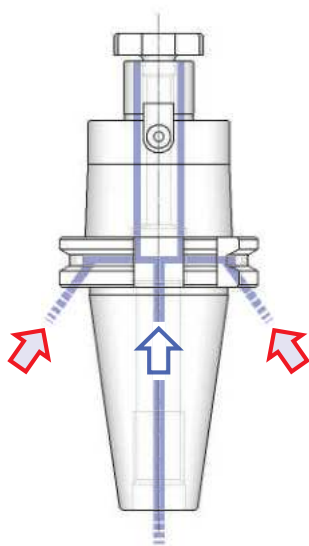

FORMA AD+B

TIPO	FORMA A	FORMA AD+B	D	L	E	Emax	0482	4562
	Art.	Art.						
TC 30 - D. 13 FISSO / H 35	3940	—	13	12	28	—	0482	—
TC 30 - D. 16 FISSO / H 35	4122	—	16	17	38	—	4985	4562
TC 30 - D. 22 FISSO / H 50	4124	—	22	19	48	—	4986	4563
TC 30 - D. 27 FISSO / H 50	4126	—	27	21	58	—	4987	4564
TC 30 - D. 32 FISSO / H 55	4143	—	32	24	58	—	4988	4565
TC 40 - D. 16 FISSO / H 45	4127	5844	16	17	38	—	4985	4562
TC 40 - D. 16 FISSO / H 100	5537	5845						
TC 40 - D. 16 FISSO / H 130	9400	9410						
TC 40 - D. 16 FISSO / H 160	8364	8385						
TC 40 - D. 16 FISSO / H 200	8365	8386						
TC 40 - D. 22 FISSO / H 45	4652	5846	22	19	48	—	4986	4563
TC 40 - D. 22 FISSO / H 100	5538	5847			46	48		
TC 40 - D. 22 FISSO / H 130	9401	9411						
TC 40 - D. 22 FISSO / H 160	5539	8387						
TC 40 - D. 22 FISSO / H 200	8366	8388						
TC 40 - D. 27 FISSO / H 50	4653	5848	27	21	58	—	4987	4564
TC 40 - D. 27 FISSO / H 100	5540	5849			48	—		
TC 40 - D. 27 FISSO / H 130	9402	9412						
TC 40 - D. 27 FISSO / H 160	5541	8389						
TC 40 - D. 27 FISSO / H 200	8367	8390						
TC 40 - D. 32 FISSO / H 55	4654	5850	32	24	78	—	4988	4565
TC 40 - D. 32 FISSO / H 100	5542	5851			58	—		
TC 40 - D. 32 FISSO / H 160	8368	8391						
TC 40 - D. 40 FISSO / H 55	4655	5852	40	27	88	—	4989	4566
TC 40 - D. 40 FISSO / H 100	4694	8392			70	—		
TC 40 - D. 40 FISSO / H 160	8369	8393						
TC 50 - D. 16 FISSO / H 45	4661	5853	16	17	38	—	4985	4562
TC 50 - D. 16 FISSO / H 100	4695	5854						
TC 50 - D. 16 FISSO / H 130	9405	9415						
TC 50 - D. 16 FISSO / H 160	8370	8394						
TC 50 - D. 16 FISSO / H 200	8371	8395						
TC 50 - D. 22 FISSO / H 45	4662	5855	22	19	48	—	4986	4563
TC 50 - D. 22 FISSO / H 100	5544	5856			46	48		
TC 50 - D. 22 FISSO / H 130	9406	9416						
TC 50 - D. 22 FISSO / H 160	5545	8396			46	60		
TC 50 - D. 22 FISSO / H 200	8372	8397						
TC 50 - D. 22 FISSO / H 250	8373	8398			48	60		
TC 50 - D. 22 FISSO / H 300	8374	8399						
TC 50 - D. 27 FISSO / H 45	4663	5857	27	21	55	78	4987	4564
TC 50 - D. 27 FISSO / H 100	5546	5858						
TC 50 - D. 27 FISSO / H 130	9407	9417						
TC 50 - D. 27 FISSO / H 160	5547	8400						
TC 50 - D. 27 FISSO / H 200	8375	8401						
TC 50 - D. 27 FISSO / H 250	8376	8402						
TC 50 - D. 27 FISSO / H 300	8377	8403						
TC 50 - D. 32 FISSO / H 55	4664	5859	32	24	66	78	4988	4565
TC 50 - D. 32 FISSO / H 100	5548	5860						
TC 50 - D. 32 FISSO / H 130	9408	9418						
TC 50 - D. 32 FISSO / H 160	5549	8404						
TC 50 - D. 32 FISSO / H 200	8378	8405						
TC 50 - D. 32 FISSO / H 250	8379	8406						
TC 50 - D. 32 FISSO / H 300	8380	8407	66	—				
TC 50 - D. 40 FISSO / H 55	4665	5861	40	27	88	—	4989	4566
TC 50 - D. 40 FISSO / H 100	5550	5862			70	—		
TC 50 - D. 40 FISSO / H 160	8381	8408						
TC 50 - D. 40 FISSO / H 200	8382	8409			70	78		

DIN 69871

ISO 7388-1

PORTAFRESE FISSI - DOPPIO CONTATTO

DOUBLE CONTACT FACE MILL HOLDERS

FORMA AD

Balanced G 6,3

8.000 rpm



DOPPIO
CONTATTO



TIPO	Art.	D	L	E	E _{max}		
TC 40 - D. 16 FISSO / H 45	10222	16	17	38	-	4985	4562
TC 40 - D. 16 FISSO / H 100	10223						
TC 40 - D. 16 FISSO / H 130	10224						
TC 40 - D. 16 FISSO / H 160	10225						
TC 40 - D. 22 FISSO / H 45	10227	22	19	48	-	4986	4563
TC 40 - D. 22 FISSO / H 100	10228						
TC 40 - D. 22 FISSO / H 130	10229			46	48		
TC 40 - D. 22 FISSO / H 160	10230						
TC 40 - D. 27 FISSO / H 50	10232	27	21	58	-	4987	4564
TC 40 - D. 27 FISSO / H 100	10233			48	-		
TC 40 - D. 32 FISSO / H 55	10237	32	24	78	-	4988	4565
TC 40 - D. 40 FISSO / H 55	10240	40	27	88	-	4989	4566
TC 50 - D. 16 FISSO / H 45	10243	16	17	38	-	4985	4562
TC 50 - D. 22 FISSO / H 45	10248	22	19	48	-	4986	4563
TC 50 - D. 27 FISSO / H 45	10255	27	21	58	-	4987	4564
TC 50 - D. 32 FISSO / H 55	10262	32	24	78	-	4988	4565
TC 50 - D. 40 FISSO / H 55	10269	40	27	88	-	4989	4566

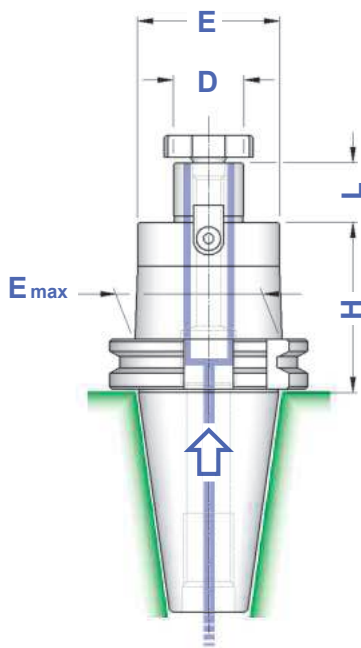

DOPPIO
CONTATTO
FORMA AD



Codoli di Aggancio
pag. 221

Pull Studs
page 221



DIN 69871

ISO 7388-1

ATTACCHI PER FRESE AD INSERTI FACE MILL HOLDERS FOR FACE MILLING CUTTERS

FORMA A

Balanced G 6,3
8.000 rpm

FORMA A



TIPO	Art.	D	H	E	C	F	T	
TC 40 - D. 40 FM	4181	40	60	89	66,7	M12	15,9	4989
TC 50 - D. 40 FM	4184	40	70	89	66,7	M12	15,9	4989
TC 50 - D. 60 FM	4185	60	70	129	101,6	M16	25,4	—

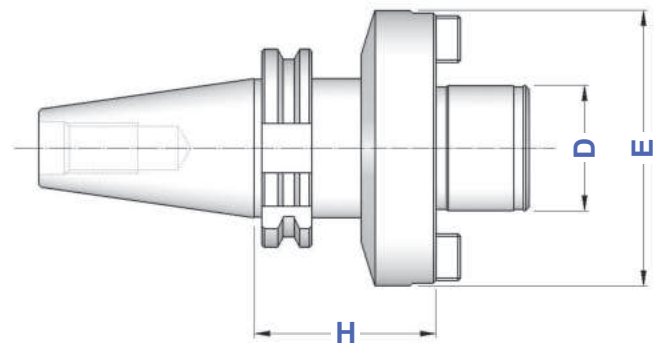
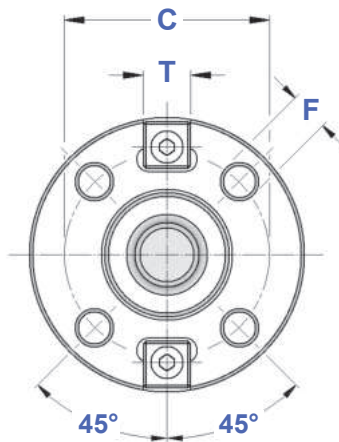

DIN 69871

ISO 7388-1

PORTAFRESE CON CHIAVETTA DI TRASCINAMENTO MILL HOLDERS WITH FEATHER KEY

FORMA A

FORMA A

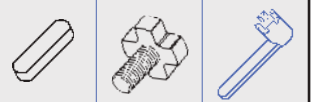

TIPO	Art.	D	H	L	E			
TC 40 - D. 16 CHT	8493	16	45	30	28	0147	4985	4562
TC 40 - D. 22 CHT	8494	22	45	40	36	0148	4986	4563
TC 40 - D. 27 CHT	8495	27	45	60	43	0149	4987	4564
TC 40 - D. 32 CHT	8496	32	45	60	48	0150	4988	4565
TC 40 - D. 40 CHT	8497	40	45	60	56	0151	4989	4566

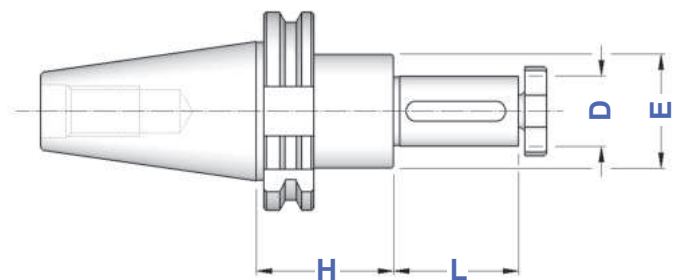

DIN 69871

ISO 7388-1





PORTAFRESE COMBINATI

DIN 6358 COMBI SHELL MILL HOLDERS

FORMA A

Balanced G 6,3
8.000 rpm



TIPO	FORMA A						E _{max}				
	Art.	D	L1	L	E						
TC30 - D.16 C/H 50	3828	16	27	17	32	-	4090	0115	4985	4562	
TC30 - D.22 C/H 50	3829	22	31	19	40	-	4091	0116	4986	4563	
TC30 - D.27 C/H 55	3830	27	33	21	48	-	4092	0122	4987	4564	
TC40 - D.16 C/H 55	3831	16	27	17	32	-	4090	0115	4985	4562	
TC40 - D.16 C/H100	4100					44					
TC40 - D.16 C/H160	8474										
TC40 - D.22 C/H 55	3832	22	31	19	40	-	4091	0116	4986	4563	
TC40 - D.22 C/H100	4101										
TC40 - D.22 C/H160	8475										
TC40 - D.27 C/H 55	3833	27	33	21	48	-	4092	0122	4987	4564	
TC40 - D.27 C/H100	4102										
TC40 - D.27 C/H160	8476										
TC40 - D.32 C/H 60	3834	32	38	24	58	-	4093	0125	4988	4565	
TC40 - D.32 C/H100	4103										
TC40 - D.32 C/H160	8477										
TC40 - D.40 C/H 60	3835	40	41	27	70	-	4094	0133	4989	4566	
TC40 - D.40 C/H100	3863										
TC45 - D.16 C/H 60	3836	16	27	17	32	-	4090	0115	4985	4562	
TC45 - D.22 C/H 65	3837	22	31	19	40	-	4091	0116	4986	4563	
TC45 - D.22 C/H100	4105										
TC45 - D.27 C/H 65	3838	27	33	21	48	-	4092	0122	4987	4564	
TC45 - D.27 C/H100	4106										
TC45 - D.32 C/H 65	3839	32	38	24	58	-	4093	0125	4988	4565	
TC45 - D.40 C/H 70	3840	40	41	27	70	-	4094	0133	4989	4566	
TC50 - D.16 C/H 55	3841	16	27	17	32	-	4090	0115	4985	4562	
TC50 - D.16 C/H100	4108					50					
TC50 - D.22 C/H 55	3842	22	31	19	40	-	4091	0116	4986	4563	
TC50 - D.22 C/H100	4109					60					
TC50 - D.27 C/H 55	3843	27	33	21	48	-	4092	0122	4987	4564	
TC50 - D.27 C/H100	4110					60					
TC50 - D.32 C/H 55	3844	32	38	24	58	-	4093	0125	4988	4565	
TC50 - D.32 C/H100	4111										
TC50 - D.40 C/H 55	3845	40	41	27	70	-	4094	0133	4989	4566	
TC50 - D.40 C/H100	4112										
TC50 - D.50 C/H 70	4522	50	46	30	90	-	4095	0137	4990	4567	

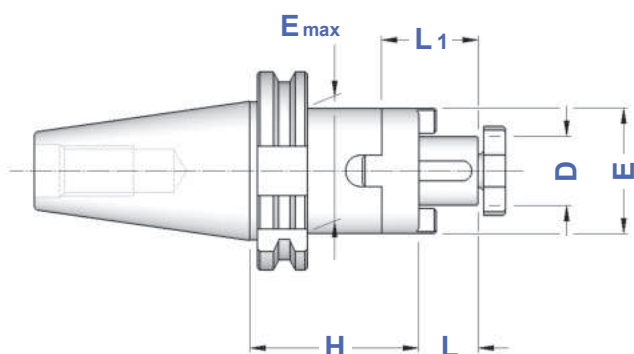

DIN 69871

ISO 7388-1

MANDRINI PER FRESE CON ATTACCO FILETTATO

CHUCKS FOR MILLING CUTTERS WITH THREADED SHANK

FORMA AD

Balanced G 6,3

12.000 rpm

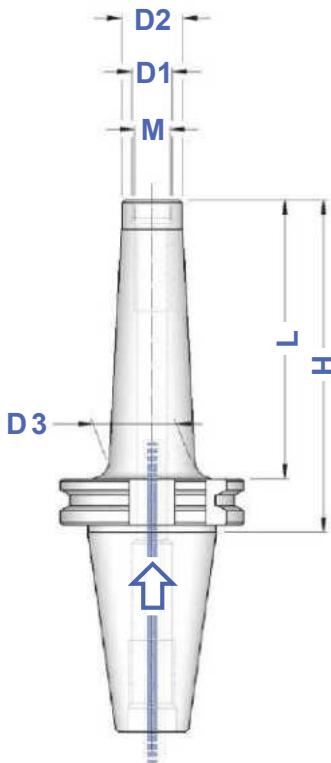

FORMA AD

FORMA AD

TIPO	Art.	M	D1	D2	D3	H	L
TC 40 - M 6/H 55	7767	M 6	6,5	10	13	55	36
TC 40 - M 6/H 69	7768				20	69	50
TC 40 - M 6/H 94	7769				23	94	75
TC 40 - M 8/H 55	7800	M 8	8,5	13	15	55	36
TC 40 - M 8/H 69	7801				23	69	50
TC 40 - M 8/H 94	7802				23	94	75
TC 40 - M 8/H 119	7803				25	119	100
TC 40 - M 10/H 55	7804	M 10	10,5	18	20	55	36
TC 40 - M 10/H 69	7805				23	69	50
TC 40 - M 10/H 94	7806				28	94	75
TC 40 - M 10/H 119	7807				32	119	100
TC 40 - M 10/H 145	7808				34	145	126
TC 40 - M 12/H 55	7809	M 12	12,5	21	24	55	36
TC 40 - M 12/H 69	7810				24	69	50
TC 40 - M 12/H 94	7811				31	94	75
TC 40 - M 12/H 119	7812				33	119	100
TC 40 - M 12/H 145	7813				38	145	126
TC 40 - M 12/H 175	7814				42	175	156
TC 40 - M 16/H 55	7815	M 16	17,0	29	32	55	36
TC 40 - M 16/H 69	7816				34	69	50
TC 40 - M 16/H 94	7817				34	94	75
TC 40 - M 16/H 119	7818				36	119	100
TC 40 - M 16/H 145	7819				40	145	126
TC 40 - M 16/H 175	7820				39	175	156
TC 40 - M 16/H 195	7999				44	195	176
TC 50 - M 10/H 69	8713				M 10	10,5	18
TC 50 - M 10/H 119	8714	28	119	100			
TC 50 - M 10/H 169	8715	32	169	150			
TC 50 - M 12/H 69	7821	M 12	12,5	21	24	69	50
TC 50 - M 12/H 119	7822				33	119	100
TC 50 - M 12/H 169	7823				40	169	150
TC 50 - M 12/H 235	8716				42	235	216
TC 50 - M 16/H 69	7824	M 16	17,0	29	34	69	50
TC 50 - M 16/H 119	7825				36	119	100
TC 50 - M 16/H 169	7826				42,5	169	150
TC 50 - M 16/H 235	8717				44	235	216

Prolunghe, Riduzioni, Portapinze ER con attacco filettato a pag. 46

Extensions, Reductions, ER Collet Chucks with threaded shank at page 46



DIN 69871

ISO 7388-1

**MASCHIATORI A CAMBIO RAPIDO CON
DOPPIA COMPENSAZIONE**
DOUBLE COMPENSATION QUICK CHANGE TAPPING CHUCKS

FORMA A



**FORMA
A**

TIPO	Art.	H	E	B	COMPENSAZIONE	
TC 30 - B. 1	2995	60	38	19	- 7,5 + 7,5	M 3 ÷ M 12 (*M18)
TC 30 - B. 2	2996	100	55	31	- 12,5 + 12,5	M 6 ÷ M 20 (*M30)
TC 40 - B. 1	3377	60	38	19	- 7,5 + 7,5	M 3 ÷ M 12 (*M18)
TC 40 - B. 2	3378	100	55	31	- 12,5 + 12,5	M 6 ÷ M 20 (*M30)
TC 40 - B. 3	3379	140	79	48	- 20,0 + 20,0	M14 ÷ M 33 (*M48)
TC 45 - B. 1	3380	60	38	19	- 7,5 + 7,5	M 3 ÷ M 12 (*M18)
TC 45 - B. 2	3381	84	55	31	- 12,5 + 12,5	M 6 ÷ M 20 (*M30)
TC 50 - B. 1	4151	62	38	19	- 7,5 + 7,5	M 3 ÷ M 12 (*M18)
TC 50 - B. 2	3383	83	55	31	- 12,5 + 12,5	M 6 ÷ M 20 (*M30)
TC 50 - B. 3	3384	133	79	48	- 20,0 + 20,0	M14 ÷ M 33 (*M48)



* Bussole con GRANI
Adapters with SCREWS

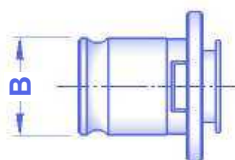
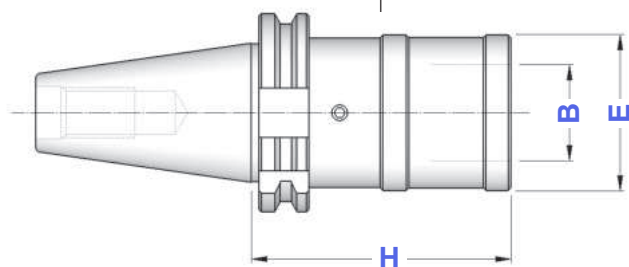
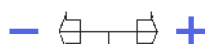

**Bussole a maschiare
da pag. 235**
Tapping Adapters
from page 235

DIN 69871

ISO 7388-1

**MASCHIATORI A CAMBIO RAPIDO
SENZA COMPENSAZIONE**
QUICK CHANGE TAPPING CHUCKS WITHOUT COMPENSATION

FORMA AD



**FORMA
AD**

TIPO	Art.	H	E	B	
TC 30 - B. 1 FISSO	4946	59	33	19	M 3 ÷ M 12 (*M18)
TC 30 - B. 2 FISSO	4947	80	50	31	M 6 ÷ M 20 (*M30)
TC 40 - B. 1 FISSO	4948	59	33	19	M 3 ÷ M 12 (*M18)
TC 40 - B. 2 FISSO	4949	86	50	31	M 6 ÷ M 20 (*M30)
TC 40 - B. 3 FISSO	4991	122	72	48	M14 ÷ M 33 (*M48)
TC 50 - B. 1 FISSO	3062	75	33	19	M 3 ÷ M 12 (*M18)
TC 50 - B. 2 FISSO	4950	98	50	31	M 6 ÷ M 20 (*M30)
TC 50 - B. 3 FISSO	4992	122	72	48	M14 ÷ M 33 (*M48)

* Bussole con GRANI
Adapters with SCREWS

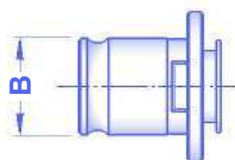
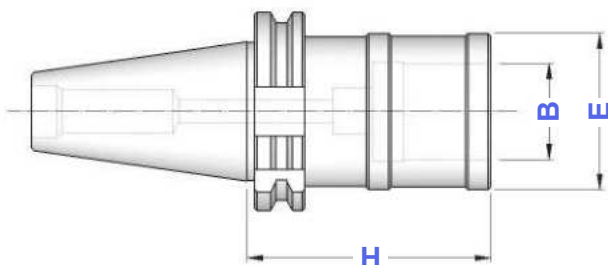

**Bussole a maschiare
da pag. 235**
Tapping Adapters
from page 235

DIN 69871

ISO 7388-1

RIDUZIONI E ADATTATORI

REDUCTIONS AND ADAPTERS



TC ⇔ ISO/TC/BT SK ⇔ NT/SK/BT

TIPO	FORMA A			DIN 2080		BT DIN 69871	
	Art.	H	E				
TC 40 - ISO 30/TC 30/BT 30	4203	60	50	* 7410	* 0177	* 7423	4570
TC 40 - ISO 40/TC 40/BT 40	8670	100	68	* 7411	* 0179	* 7424	4571
TC 50 - ISO 40/TC 40/BT 40	4257	70	68	* 7411	* 0179	* 7424	4571
TC 50 - ISO 50/TC 50/BT 50	8671	120	100	* 7417	* 0254	* 7426	4780

* Compresi nella fornitura
Included in the supply



TC ⇔ HSK A+C

DIN 69871 ⇔ DIN 69893-1
(ISO 7388-1 ⇔ ISO 12164-1)

TIPO	FORMA AD+B		
	Art.	H	E
TC 40 - HSK 50 A+C	6594	60	50
TC 40 - HSK 63 A+C	6595	80	63
TC 50 - HSK 63 A+C	6596	60	63



TC ⇔ POLIGONALE

DIN 69871 ⇔ ISO 26623-1
(ISO 7388-1 ⇔ ISO 26623-1)

TIPO	FORMA AD+B		DOPPIO CONTATTO	
	Art.	Art.	H	E
TC 40 - C 40/H 30	11000	11014	30	40
TC 40 - C 40/H 60	11001	—	60	40
TC 40 - C 50/H 40	11002	—	40	50
TC 40 - C 50/H 50	—	11015	50	50
TC 40 - C 63/H 85	11003	11016	85	63
TC 50 - C 40/H 30	11004	11017	30	40
TC 50 - C 40/H 60	11005	11018	60	40
TC 50 - C 50/H 30	11006	11019	30	50
TC 50 - C 50/H 70	11007	11020	70	50
TC 50 - C 50/H 110	11008	—	110	50
TC 50 - C 63/H 30	11009	11021	30	63
TC 50 - C 63/H 50	11010	11022	50	63
TC 50 - C 63/H 80	11011	—	80	63
TC 50 - C 63/H 100	—	11023	100	63
TC 50 - C 80/H 70	11012	11024	70	80
TC 50 - C 80/H 120	11013	11025	120	80

CARATTERISTICHE TECNICHE CONI BT (MAS 403 / JIS-B 6339 / ISO 7388-2)

BT TAPERS (MAS 403 / JIS-B 6339 / ISO 7388-2) STANDARD FEATURES

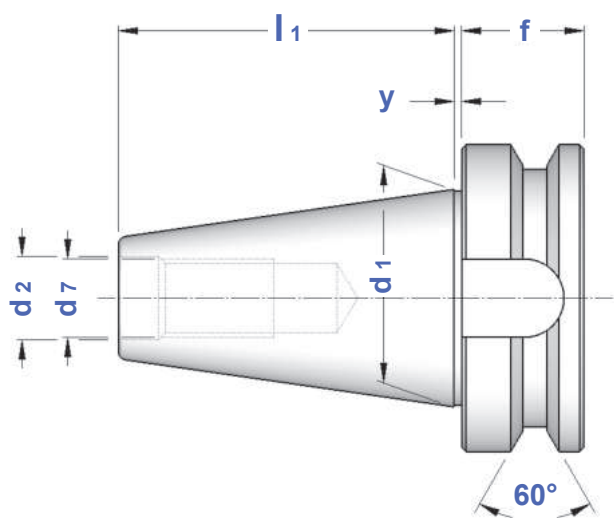

FORMA A (J)

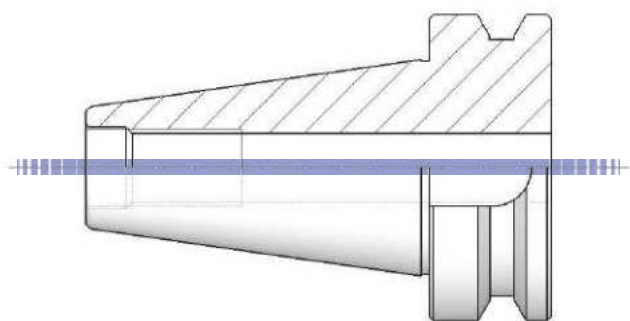
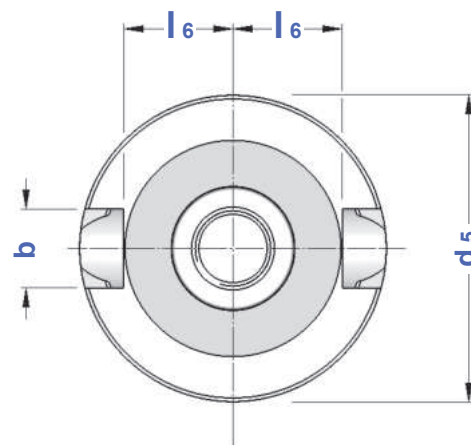

FORMA AD (JD)

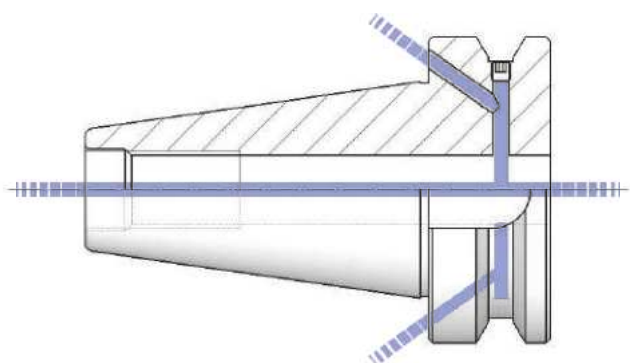
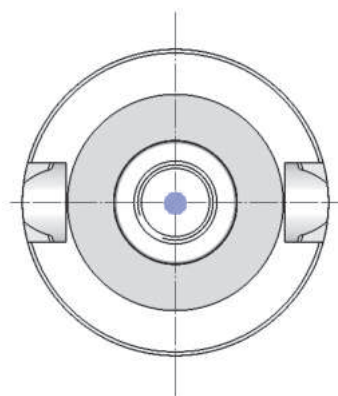

FORMA AD+B (JD/JF)

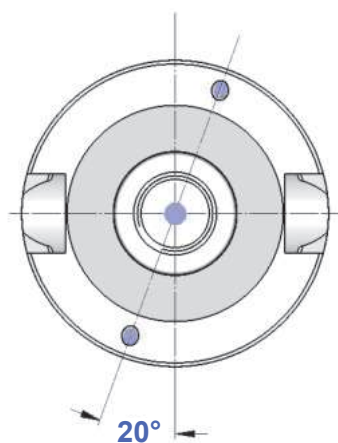

CONO	y	b	d1	d2	d5	d7	f	l1	l6	PRECISIONE
BT 30	2	16,1	31,75	12,5	46	M 12	20	48,4	16,3	
BT 35 /1	2	14,1	38,10	13	53	M 12	20	56,5	19,3	
BT 35 /2	2	16,1	38,10	12,5	53	M 12	22	56,5	19,6	
BT 40	2	16,1	44,45	17	63	M 16	25	65,4	22,6	
BT 45	3	19,3	57,15	21	85	M 20	30	82,8	29,1	
BT 50	3	25,7	69,85	25	100	M 24	35	101,8	35,4	

INDICE DELL' ATTACCO BT (MAS 403 / JIS-B 6339 / ISO 7388-2)

INDEX OF BT SHANK (MAS 403 / JIS-B 6339 / ISO 7388 - 2)

AUTOSERRANTI INTEGRALI

MONOLITHIC DRILL CHUCKS

pag. 130

**attacchi per AUTOSERRANTI**SHANKS for
DIN 238 DRILL CHUCKS

pag. 131

**PORTAPINZA ER EXTRACORTI**ER SHORT COLLET CHUCKS
with INNER NUT

pag. 131

**PORTAPINZA ER ghiera MINI**ER MINI NUT
COLLET CHUCKS

pag. 132

**PORTAPINZA ER ghiera ESAGONALE**ER HEXAGONAL NUT
COLLET CHUCKS

pag. 133

**PORTAPINZA ER ghiera STANDARD**ER STANDARD NUT
COLLET CHUCKS

pag. 134 - 135

**mandrini per PINZE EOC**DIN 6388 EOC
COLLET CHUCKS

pag. 136

**FORTE SERRAGGIO**

HIGH GRIP CHUCKS

pag. 137

**SERRAGGIO IDRAULICO**

HYDRAULIC CHUCKS

pag. 138

**BARRE a STELO TENERO**

BLANK BARS

pag. 139

**BARRE di CONTROLLO**

TEST ARBORS

pag. 139

**PORTA PUNTE ad INSERTI**

INDEXABLE DRILL HOLDERS

pag. 140

**PORTAFRESE WELDON EXTRACORTI**

SHORT TYPE END MILL HOLDERS

pag. 141

**PORTAFRESE WELDON**END MILL HOLDERS
for DIN 1835-B SHANK

pag. 142 - 143

**WELDON con CANALI di REFRIGERAZIONE**END MILL HOLDERS
with COOLANT CHANNELS

pag. 144

**PORTAFRESE WHISTLE NOTCH**END MILL HOLDERS
for DIN 1835-E SHANK

pag. 145



➔ segue
continue

**riduzioni a CONO MORSE
per PUNTE e per FRESE**

*MT ADAPTERS for TWIST DRILLS and
for MILLING CUTTERS*
pag. 146 - 147



PORTAFRESE ad INSERTI

*FACE MILL HOLDERS for
FACE MILLING CUTTERS*

pag. 150



PORTAFRESE COMBINATI

*COMBI
SHELL MILL HOLDERS*

pag. 151



MASCHIATORI

TAPPING CHUCKS

pag. 153



riduzioni da ISO a HSK

ISO to HSK ADAPTERS

pag. 154



CODOLI di AGGANCI

PULL STUDS

pag. 221



**SMONTACONI
ORIENTABILI**

*ORIENTABLE
TIGHTENING FIXTURES*
pag. 240



PORTAFRESE FISSI

FACE MILL HOLDERS

pag. 148 - 149



**P/FRESE con CHIAVETTA
di TRASCINAMENTO**

*MILLING CUTTER HOLDERS
with FEATHER KEY*

pag. 150



**PORTA FRESE con
ATTACCO FILETTATO**

*THREADED SHANK
MILLING CUTTERS HOLDERS*

pag. 152



riduzioni da ISO a ISO

ISO to ISO ADAPTERS

pag. 154



**riduzioni da ISO
a POLIGONALE**

*ISO to POLYGONAL
ADAPTERS*

pag. 154



TAMPONI PULITORI

TAPER CLEANERS

pag. 243



MAGAZZINI PORTACONI

TOOL STORES

pag. 244 - 245



BT	MANDRINI AUTOSERRANTI INTEGRALI ROTAZIONE DESTRA	FORMA A (J)
	MONOLITHIC DRILL CHUCKS - RIGHT SPIN	

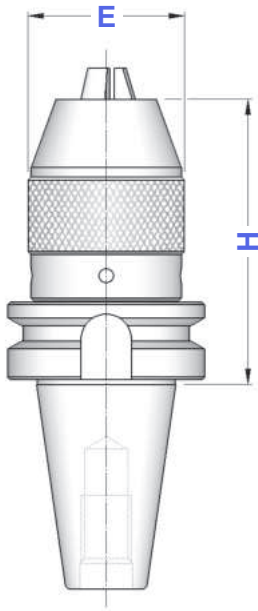

TIPO	FORMA A		RANGE	E	H			
	Art.	Art.						
BT 30 - DC 13	8593		0,5 ÷ 13	50	90	9016	9021	2370
BT 40 - DC 13	4392		0,5 ÷ 13	50	90	9016	9021	2370
BT 40 - DC 16	4393		3 ÷ 16	57	120	9017	9023	2371
BT 50 - DC 13	4394		0,5 ÷ 13	50	110	9016	9021	2370
BT 50 - DC 16	4395		3 ÷ 16	57	110	9017	9023	2371



Forniti completi dell'apposita chiave
Supplied complete with suitable wrench

BT	MANDRINI AUTOSERRANTI INTEGRALI ROTAZIONE DESTRA E SINISTRA	FORMA AD (JD)
	MONOLITHIC DRILL CHUCKS - RIGHT & LEFT SPIN	FORMA AD+B (JD/JF)

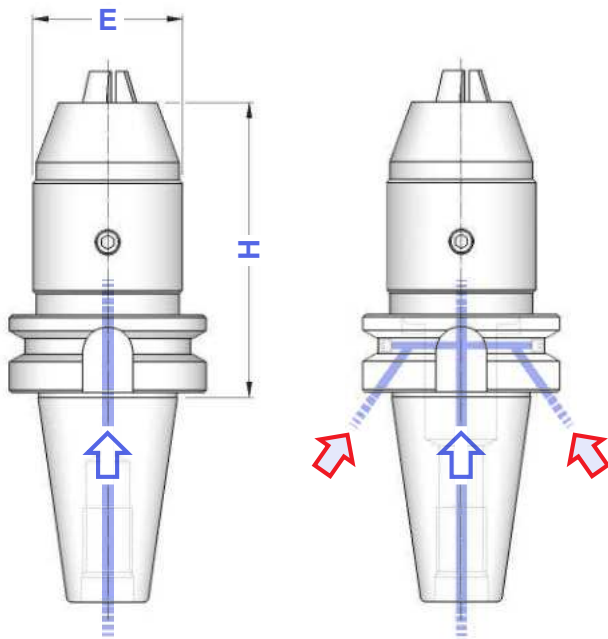

FORMA AD

FORMA AD+B

TIPO	FORMA AD	FORMA AD+B	RANGE	E	H	
	Art.	Art.				
BT 30 - DCU 13	8594	—	0,5 ÷ 13	50	100	2372
BT 40 - DCU 13	8595	8599	0,5 ÷ 13	50	98	
BT 40 - DCU 16	8596	8600	3 ÷ 16	50	103	2372
BT 50 - DCU 13	8597	8601	0,5 ÷ 13	50	110	
BT 50 - DCU 16	8598	8602	3 ÷ 16	50	112	2372



Forniti completi dell'apposita chiave
Supplied complete with suitable wrench

BT	ATTACCHI PER MANDRINI AUTOSERRANTI SHANKS FOR DRILL CHUCKS DIN 238 / ISO 239 TYPE	FORMA A (J)
----	---	-------------

Balanced G 6,3
8.000 rpm

FORMA A

TIPO	Art.	D	H
BT 30 - B16	3994	15,733	40
BT 40 - B12	3865	12,065	40
BT 40 - B16	3866	15,733	40
BT 40 - B18	3995	17,780	40
BT 50 - B16	3996	15,733	45
BT 50 - B18	3997	17,780	45

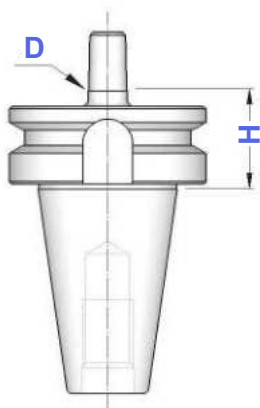

I Mandrini Autoserranti si trovano a pagina 62

Keyless Drill Chucks you can find at page 62

BT	PORTAPINZA ER EXTRACORTI ER SHORT COLLET CHUCKS with INNER NUT	FORMA AD
----	--	----------

Balanced G 6,3
15.000 rpm

FORMA AD

TIPO	Art.	H	RANGE			
BT 40 - ER25 GA	8041	29	ER25 1÷20	2870	3172	0996
BT 40 - ER32 GA	3067	29	ER32 2÷25	2871	3173	0988
BT 50 - ER32 GA	3068	40	ER32 2÷25	2871	3173	0988

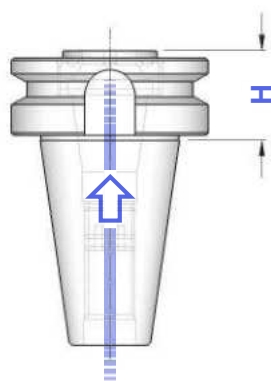
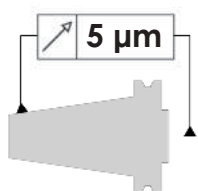

FORMA AD



BT



PORTAPINZA ER - GHIERA MINI
ER COLLET CHUCKS with MINI NUT

FORMA AD (JD)

FORMA AD+B (JD/JF)

Balanced	G 6,3
≤ H130	15.000 rpm
≥ H160	8.000 rpm



TIPO	FORMA AD	FORMA AD+B	D	RANGE			
	Art.	Art.					
BT 30 - ER 11 GM /H 80	3329	—	16	ER11 1÷8	0432	5718	5573
BT 30 - ER 16 GM /H 80	3039	—	22	ER16 1÷12	1229	5719	0364
BT 30 - ER 16 GM /H 120	3454	—					
BT 40 - ER 11 GM /H 70	3271	4855	16	ER11 1÷8	0432	5718	5573
BT 40 - ER 11 GM /H 100	3174	4856					
BT 40 - ER 11 GM /H 130	3272	4857					
BT 40 - ER 11 GM /H 160	4687	4858					
BT 40 - ER 16 GM /H 70	3455	4859	22	ER16 1÷12	1229	5719	0364
BT 40 - ER 16 GM /H 100	3456	4860					
BT 40 - ER 16 GM /H 130	3457	4861					
BT 40 - ER 16 GM /H 160	4688	4862					
BT 40 - ER 16 GM /H 200	4781	4812					
BT 40 - ER 20 GM /H 70	3041	4501	28	ER20 1÷15	1230	5720	0787
BT 40 - ER 20 GM /H 100	3461	4863					
BT 40 - ER 20 GM /H 130	3458	4864					
BT 40 - ER 20 GM /H 160	4689	4865					
BT 40 - ER 20 GM /H 200	4782	4813					
BT 40 - ER 25 GM /H 70	3043	4656	35	ER25 1÷20	1231	5721	0996
BT 40 - ER 25 GM /H 100	3175	4866					
BT 40 - ER 25 GM /H 130	4690	4867					
BT 40 - ER 25 GM /H 160	3459	4868					
BT 40 - ER 25 GM /H 200	3460	4814					
BT 50 - ER 16 GM /H 130	3463	4869	22	ER16 1÷12	1229	5719	0364
BT 50 - ER 16 GM /H 160	3494	4833					
BT 50 - ER 16 GM /H 200	3495	4834					
BT 50 - ER 20 GM /H 130	3464	4870	28	ER20 1÷15	1230	5720	0787
BT 50 - ER 20 GM /H 160	3045	4657					
BT 50 - ER 20 GM /H 200	3048	4658					
BT 50 - ER 25 GM /H 130	3051	4659	35	ER25 1÷20	1231	5721	0996
BT 50 - ER 25 GM /H 160	3462	4871					
BT 50 - ER 25 GM /H 200	3061	4660					

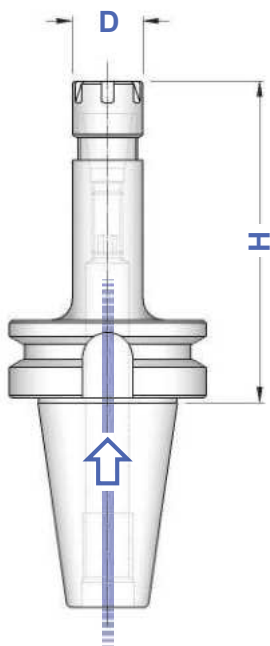

FORMA AD

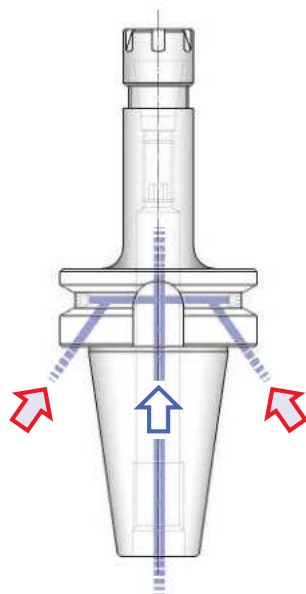

FORMA AD+B



BT



PORTAPINZA ER - GHIERA ESAGONALE
ER COLLET CHUCKS with HEXAGONAL NUT

FORMA AD (JD)

FORMA AD+B (JD/JF)

Balanced	G 6,3
≤ H130	15.000 rpm
≥ H160	8.000 rpm



TIPO	FORMA AD	FORMA AD+B	DOPPIO CONTATTO	D	RANGE			
	Art.	Art.	Art.					
BT 30 - ER 16 GE/H 55	8084	—	10531	28	ER16 1÷12	1214	2906	0364
BT 30 - ER 16 GE/H 100	8085	—	10532					
BT 30 - ER 20 GE/H 55	8086	—	10533	34	ER20 1÷15	1215	2907	0787
BT 30 - ER 20 GE/H 100	8087	—	10534					
BT 40 - ER 11 GE/H 70	3447	4843	—	19	ER11 1÷8	1157	2905	5573
BT 40 - ER 11 GE/H 100	3448	4844	—					
BT 40 - ER 11 GE/H 130	3449	4845	—					
BT 40 - ER 11 GE/H 160	3450	4846	—					
BT 40 - ER 16 GE/H 70	8088	8104	10539	28	ER16 1÷12	1214	2906	0364
BT 40 - ER 16 GE/H 100	8089	8105	10540					
BT 40 - ER 16 GE/H 130	8090	8106	—					
BT 40 - ER 16 GE/H 160	8091	8107	—					
BT 40 - ER 16 GE/H 200	8092	8108	—					
BT 40 - ER 20 GE/H 70	8093	8109	10544					
BT 40 - ER 20 GE/H 100	8094	8110	10545	34	ER20 1÷15	1215	2907	0787
BT 40 - ER 20 GE/H 130	8095	8111	—					
BT 40 - ER 20 GE/H 160	8096	8112	—					
BT 40 - ER 20 GE/H 200	8097	8113	—					
BT 50 - ER 16 GE/H 100	8098	8114	—					
BT 50 - ER 16 GE/H 160	8099	8115	—	28	ER16 1÷12	1214	2906	0364
BT 50 - ER 16 GE/H 200	8100	8116	—					
BT 50 - ER 20 GE/H 100	8101	8117	—					
BT 50 - ER 20 GE/H 160	8102	8118	—	34	ER20 1÷15	1215	2907	0787
BT 50 - ER 20 GE/H 200	8103	8119	—					

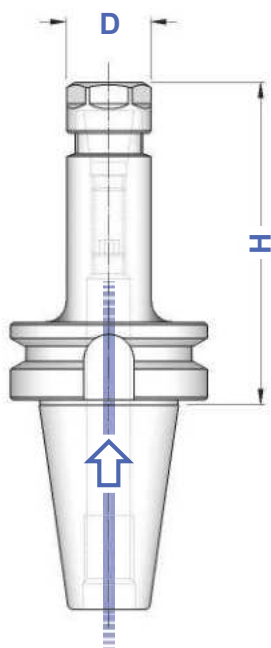

FORMA AD

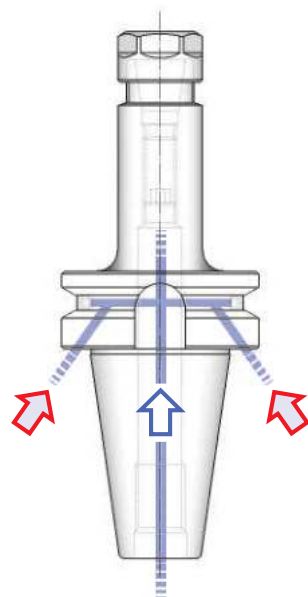

FORMA AD+B

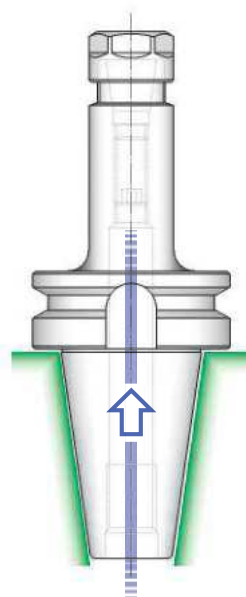

DOPPIO CONTATTO
FORMA AD

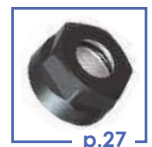

BT

PORTAPINZA ER - GHIERA STANDARD

ER COLLET CHUCKS with STANDARD NUT

FORMA AD (JD)

FORMA AD+B (JD/JF)

Balanced	G 6,3
≤ H130	15.000 rpm
≥ H160	8.000 rpm



TIPO	FORMA AD	FORMA AD+B	DOPPIO CONTATTO	D	RANGE			
	Art.	Art.	Art.					
BT 30 - ER16/H 55	3465	—	10555	32	ER16 1÷12	4993	3698	0364
BT 30 - ER16/H 100	3438	—	10556					
BT 30 - ER20/H 55	3274	—	10557	35	ER20 1÷15	4994	3699	0787
BT 30 - ER20/H 100	3439	—	10558					
BT 30 - ER25/H 55	3250	—	10559	42	ER25 1÷20	4995	3669	0996
BT 30 - ER25/H 100	3267	—	10560					
BT 30 - ER32/H 60	3251	—	10561	50	ER32 2÷25	4996	3670	0988
BT 30 - ER32/H 100	3252	—	10562					
BT 40 - ER11/H 70	3447	4843	—	19	ER11 1÷8	1157 GE	2905 CE	5573
BT 40 - ER11/H 100	3448	4844	—					
BT 40 - ER11/H 130	3449	4845	—					
BT 40 - ER11/H 160	3450	4846	—					
BT 40 - ER16/H 70	3468	4872	10567	32	ER16 1÷12	4993	3698	0364
BT 40 - ER16/H 100	3469	4873	10568					
BT 40 - ER16/H 130	3497	4847	—					
BT 40 - ER16/H 160	3470	4874	—					
BT 40 - ER16/H 200	3498	4852	—					
BT 40 - ER20/H 70	3257	4875	10572					
BT 40 - ER20/H 100	3580	4876	10573					
BT 40 - ER20/H 130	3113	4853	—					
BT 40 - ER20/H 160	3114	4877	—					
BT 40 - ER20/H 200	3499	4854	—					
BT 40 - ER25/H 70	3258	4878	10577	42	ER25 1÷20	4995	3669	0996
BT 40 - ER25/H 100	0336	4879	10578					
BT 40 - ER25/H 130	0337	4880	10579					
BT 40 - ER25/H 160	3115	4881	10580					
BT 40 - ER25/H 200	3183	4811	—					
BT 40 - ER32/H 70	3184	4882	10582					
BT 40 - ER32/H 100	3259	4883	10583					
BT 40 - ER32/H 130	3116	4884	10584					
BT 40 - ER32/H 160	3260	4885	10585					
BT 40 - ER32/H 200	3117	4886	—					
BT 40 - ER40/H 70	3261	4887	10587	63	ER40 3÷32	4997	3671	0821
BT 40 - ER40/H 100	3262	4888	10588					
BT 40 - ER40/H 130	3263	4889	—					
BT 40 - ER40/H 160	3264	4890	—					
BT 40 - ER40/H 200	3118	4891	—					
BT 40 - ER50/H 85	3265	4931	10592					

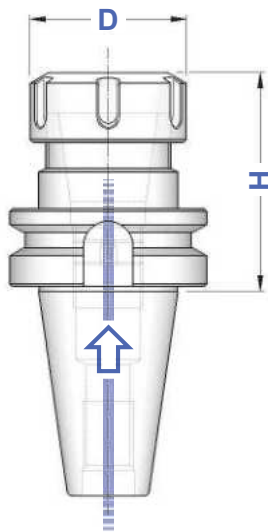

segue continue

FORMA AD

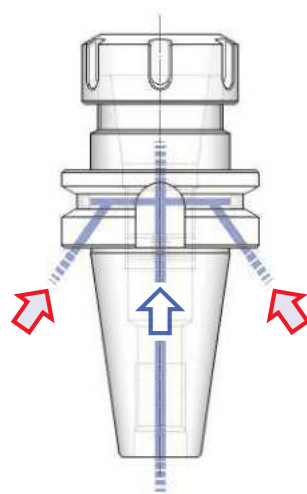

FORMA AD+B

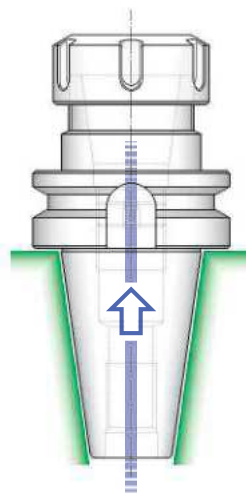





DOPPIO CONTATTO
FORMA AD

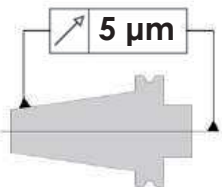

➔ segue
continue

Balanced	G 6,3
≤ H130	15.000 rpm
≥ H160	8.000 rpm







TIPO	FORMA AD	FORMA AD+B	DOPPIO CONTATTO	D	RANGE			
	Art.	Art.	Art.					
BT 50 - ER16/H 100	3474	4892	—	32	ER16 1÷12	4993	3698	0364
BT 50 - ER16/H 160	3475	4893	—					
BT 50 - ER16/H 200	3488	4957	—					
BT 50 - ER20/H 100	3119	4894	—	35	ER20 1÷15	4994	3699	0787
BT 50 - ER20/H 160	3120	4895	—					
BT 50 - ER20/H 200	3581	4958	—					
BT 50 - ER25/H 80	3582	4896	10599	42	ER25 1÷20	4995	3669	0996
BT 50 - ER25/H 100	3583	4897	10600					
BT 50 - ER25/H 160	3584	4898	—					
BT 50 - ER25/H 200	3585	4959	—					
BT 50 - ER32/H 80	3275	4899	10603	50	ER32 2÷25	4996	3670	0988
BT 50 - ER32/H 100	3273	4900	10604					
BT 50 - ER32/H 130	3276	4901	10605					
BT 50 - ER32/H 160	3277	4902	10606					
BT 50 - ER32/H 200	3278	4903	10607					
BT 50 - ER32/H 250	3400	4961	—					
BT 50 - ER40/H 80	3279	4904	10609	63	ER40 3÷32	4997	3671	0821
BT 50 - ER40/H 100	3472	4905	—					
BT 50 - ER40/H 130	3280	4906	—					
BT 50 - ER40/H 160	3281	4907	—					
BT 50 - ER40/H 200	3282	4908	—					
BT 50 - ER50/H 100	3473	4999	—	78	ER50 6÷36	4998	3668	4055
BT 50 - ER50/H 160	8046	8047	—					

**KIT CON SERIE RIDOTTA
DI PINZE ER, MANDRINO "FORMA AD" E CHIAVE**

EQUIPMENT CASES WITH REDUCED SET OF ER COLLETS,
"FORM AD" COLLET CHUCK AND WRENCH



FORMA AD





TIPO	Art.				
KIT Rid BT 30/H 55 - ER 25	7784	3250	7022	3669	0996: Ø 4 - 6 - 8 - 10 - 12 - 16
KIT Rid BT 30/H 60 - ER 32	7785	3251	7023	3670	0988: Ø 4 - 6 - 8 - 10 - 12 - 16 - 20
KIT Rid BT 40/H 70 - ER 25	7786	3258	7022	3669	0996: Ø 4 - 6 - 8 - 10 - 12 - 16
KIT Rid BT 40/H 70 - ER 32	7787	3184	7023	3670	0988: Ø 4 - 6 - 8 - 10 - 12 - 16 - 20
KIT Rid BT 40/H 70 - ER 40	7788	3261	7024	3671	0821: Ø 4 - 6 - 8 - 10 - 12 - 16 - 20 - 25
KIT Rid BT 50/H 80 - ER 32	7789	3275	7023	3670	0988: Ø 4 - 6 - 8 - 10 - 12 - 16 - 20
KIT Rid BT 50/H 80 - ER 40	7790	3279	7024	3671	0821: Ø 4 - 6 - 8 - 10 - 12 - 16 - 20 - 25

**KIT CON SERIE COMPLETA
DI PINZE ER, MANDRINO "FORMA AD" E CHIAVE**

EQUIPMENT CASES WITH COMPLETE SET OF ER COLLETS,
"FORM AD" COLLET CHUCK AND WRENCH



FORMA AD

TIPO	Art.				
KIT BT 30/H 55 - ER 25	7791	3250	7022	3669	0996: Ø 2 ÷ 16 (15 Pinze)
KIT BT 30/H 60 - ER 32	7792	3251	7023	3670	0988: Ø 3 ÷ 20 (18 Pinze)
KIT BT 40/H 70 - ER 25	7793	3258	7022	3669	0996: Ø 2 ÷ 16 (15 Pinze)
KIT BT 40/H 70 - ER 32	7794	3184	7023	3670	0988: Ø 3 ÷ 20 (18 Pinze)
KIT BT 40/H 70 - ER 40	7795	3261	7024	3671	0821: Ø 4 ÷ 26 (23 Pinze)
KIT BT 50/H 80 - ER 32	7796	3275	7023	3670	0988: Ø 3 ÷ 20 (18 Pinze)
KIT BT 50/H 80 - ER 40	7797	3279	7024	3671	0821: Ø 4 ÷ 26 (23 Pinze)

BT



MANDRINI PER PINZE EOC DIN 6388
DIN 6388 COLLET CHUCKS

FORMA AD+B (JD/JF)

Balanced G 6,3
12.000 rpm

FORMA AD+B



TIPO	Art.	D	RANGE			
BT 40 - EOC 16 / H 70 BT 40 - EOC 16 / H 100 BT 40 - EOC 16 / H 130	8726 8727 8728	43	EOC 16 2÷16	4067	2883	0768
BT 40 - EOC 25 / H 70 BT 40 - EOC 25 / H 100 BT 40 - EOC 25 / H 130	8729 8730 8731	60	EOC 25 2÷25	4068	2909	0769
BT 40 - EOC 32 / H 80	8732	72	EOC 32 3÷32	4069	2910	0770
BT 50 - EOC 16 / H 70 BT 50 - EOC 16 / H 100	8733 8734	43	EOC 16 2÷16	4067	2883	0768
BT 50 - EOC 25 / H 85 BT 50 - EOC 25 / H 100 BT 50 - EOC 25 / H 130	8735 8736 8737	60	EOC 25 2÷25	4068	2909	0769
BT 50 - EOC 32 / H 95 BT 50 - EOC 32 / H 130	8738 8739	72	EOC 32 3÷32	4069	2910	0770

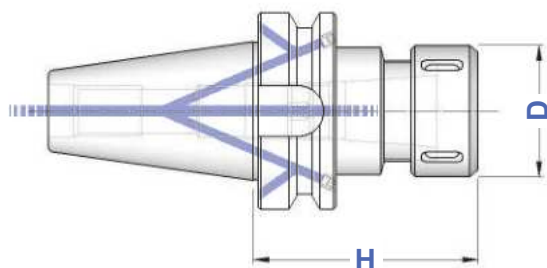

Pinze, ghiera e chiavi EOC - DIN 6388 si trovano da pagina 268
Collets, nuts and wrenches EOC - DIN 6388 type you can find from page 268



SERIE RIDOTTA DI PINZE EOC
REDUCED SET OF EOC COLLETS

TIPO	Diametri	n° pinze	Art.	Art.
EOC 16 - Ridotta	Ø 4 - 6 - 8 - 10 - 12 - 16	6	7010	7016
EOC 25 - Ridotta	Ø 6 - 8 - 10 - 12 - 16 - 20 - 25	7	7011	7017
EOC 32 - Ridotta	Ø 6 - 8 - 10 - 12 - 16 - 20 - 25 - 32	8	7012	7018

IN CONFEZIONI SINGOLE
IN SINGLE PACKS



IN VALIGETTA
IN CASE



SERIE COMPLETA DI PINZE EOC
COMPLETE SET OF EOC COLLETS

TIPO	Diametri	n° pinze	Art.	Art.
EOC 16 - Completa	da Ø 2 a Ø 16	15	7013	7019
EOC 25 - Completa	da Ø 2 a Ø 25	24	7014	7020
EOC 32 - Completa	da Ø 4 a Ø 32	29	7015	7021

IN CONFEZIONI SINGOLE
IN SINGLE PACKS



IN VALIGETTA
IN CASE



BT

MANDRINI A FORTE SERRAGGIO
HIGH GRIP CHUCKS

FORMA AD (JD)

FORMA AD+B (JD/JF)

Balanced G 6,3
12.000 rpm



TIPO	FORMA AD	FORMA AD+B	DOPPIO CONTATTO	E	D	0804
	Art.	Art.	Art.			
BT 40 - PC 12/H 65	9640	9645	10850	34	12	0804
BT 40 - PC 12/H 120	9641	9646	10851			
BT 40 - PC 16/H 65	9642	9647	10852	42	16	0805
BT 40 - PC 16/H 120	9643	9648	10853			
BT 40 - PC 20/H 80	5114	5228	10854	54	20	0809
BT 40 - PC 20/H 105	3504	—	10855			
BT 40 - PC 20/H 120	9644	9649	10856	50		
BT 40 - PC 32/H 85	—	5229	10857	63	32	0810
BT 40 - PC 32/H 105	3505	—	10858	72		
BT 40 - PC 32/H 135	5133	9650	10859	63		
BT 50 - PC 20/H 105	3506	9651	—	54	20	0809
BT 50 - PC 20/H 135	—	9652	—	50		
BT 50 - PC 32/H 105	3507	9653	—	72	32	0810
BT 50 - PC 32/H 135	5136	9654	—			



Forniti completi dell'apposita chiave
Supplied complete with suitable wrench

Pinze precisione standard pag. 270
Pinze alta precisione pag. 271
Standard precision collets page 270
High precision collets page 271

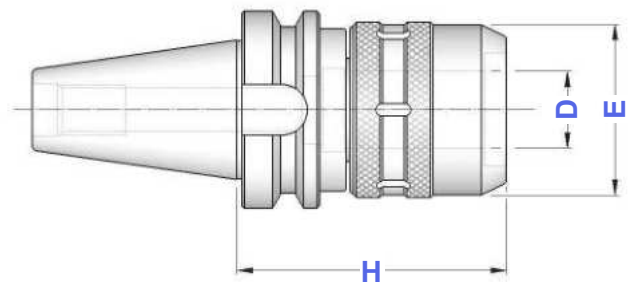

**KIT CON MANDRINO
CHIAVE E PINZE**
EQUIPMENT CASES WITH COLLET CHUCK
WRENCH AND COLLETS

FORMA AD

TIPO	Art.	5114	3695	2900	0809
KIT BT 40 - PC 20 / H 80	7547	5114	3695	2900	0809 ø 6 - 8 - 10 - 12 - 16
KIT BT 40 - PC 20 / H 105	7713	3504	3695	2910	0810 ø 6 - 8 - 10 - 12 - 16 - 20 - 25
KIT BT 40 - PC 32 / H 105	7716	3505	3695	2910	0810 ø 6 - 8 - 10 - 12 - 16 - 20 - 25
KIT BT 50 - PC 20 / H 105	7717	3506	3695	2900	0809 ø 6 - 8 - 10 - 12 - 16
KIT BT 50 - PC 32 / H 105	7720	3507	3695	2910	0810 ø 6 - 8 - 10 - 12 - 16 - 20 - 25



BT	MANDRINI A SERRAGGIO IDRAULICO	FORMA AD (JD)
	HYDRAULIC CHUCKS	FORMA AD+B (JD/JF)

Balanced G 2,5
25.000 rpm

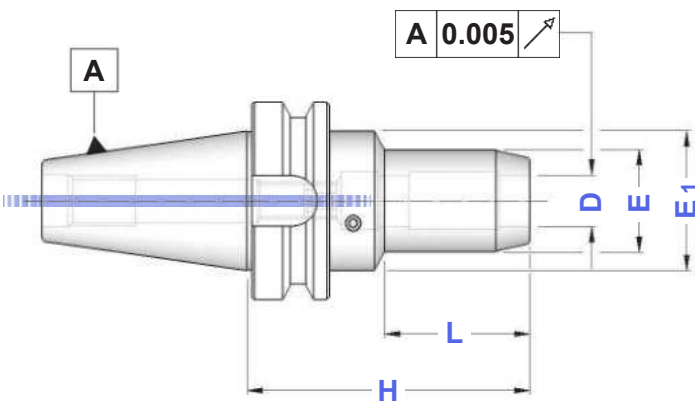

FORMA
AD

TIPO	Art.	D	H	E	E1	L
BT 40 - HYDRO 6	5171	6	90	28	50	44
BT 40 - HYDRO 8	5172	8	90	30	50	44
BT 40 - HYDRO 10	5173	10	90	32	50	44
BT 40 - HYDRO 12	5174	12	90	34	50	44
BT 40 - HYDRO 16	5175	16	90	38	50	48
BT 40 - HYDRO 20	5176	20	90	43	50	48
BT 40 - HYDRO 25	5177	25	100	57	-	73
BT 40 - HYDRO 32	5178	32	105	63	-	-
BT 50 - HYDRO 8	8509	8	90	30	50	32
BT 50 - HYDRO 10	8510	10	90	32	50	32
BT 50 - HYDRO 12	8511	12	90	34	50	32
BT 50 - HYDRO 16	8512	16	90	38	50	32
BT 50 - HYDRO 20	8513	20	90	43	50	32
BT 50 - HYDRO 25	8514	25	105	57	-	67
BT 50 - HYDRO 32	8515	32	115	63	-	77

Applicazioni: bloccaggio ad alta precisione di utensili a gambo cilindrico in tolleranza h6

Attenzione : non azionare il sistema idraulico se l'utensile non è inserito completamente nel mandrino

Applications : high precision locking of cylindrical shank tools with shank tolerance h6

Warning : do not start Hydraulic System if tool is not completely fitted into the spindle



TIPO COMPATTO
COMPACT TYPE

FORMA AD	FORMA AD+B
-----------------	-------------------

TIPO	Art.	Art.	D	H	E1
BT 40 - HYDRO 20 C	5116	5170	20	72,5	49,5
BT 50 - HYDRO 32 C	5117	5180	32	90,0	72,0

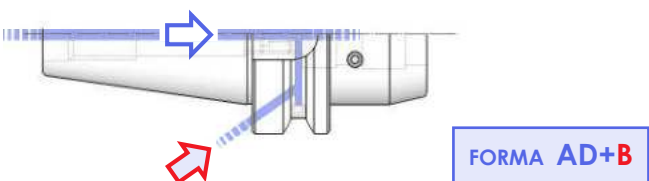
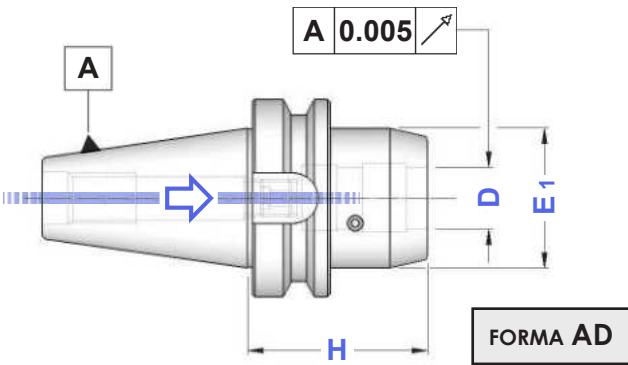

Pinze per Mandrini Idraulici pag. 272
Watertight collets on page 272

BT

BARRE A STELO TENERO
BLANK BARS



TIPO	Art.	D	H
BT 40 - D. 40 ST	4367	40	160
BT 40 - D. 50 ST	4368	50	200
BT 40 - D. 63 ST	4369	63	250
BT 50 - D. 63 ST	4372	63	250
BT 50 - D. 80 ST	4373	80	300

BT

BARRE DI CONTROLLO
TEST ARBORS



Fig. 1

TIPO	Art.	Fig.	H	D
BT 40 - D. 40 SC	2227	1	300	40
BT 50 - D. 50 SC	2229	1	350	50

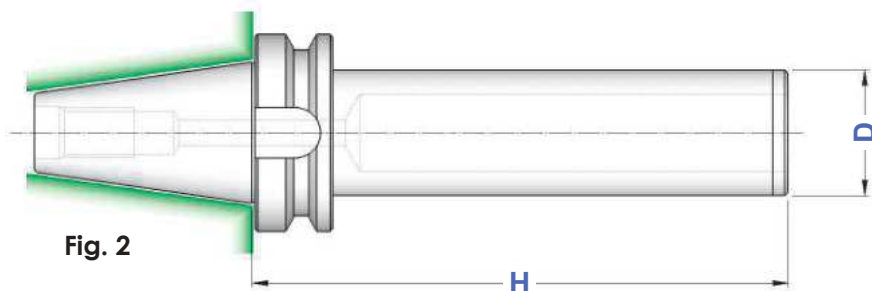

Fig. 2

**DOPPIO
CONTATTO**

TIPO	Art.	Fig.	H	D
BT 40 - D. 40 SC 2	10823	2	300	40
BT 50 - D. 50 SC 2	10824	2	350	50

Dati costruttivi

- Costruite in acciaio da cementazione certificato
- Cementate con profondità 0,6 - 0,8 mm
- Temperate, rinvenute, brunite
- Durezza HRC 58 ± 2, resistenza 800-1000 N/mm²
- Rotondità in rotazione 0,005
- Cilindricità 0,003

Constructive Features

- Manufactured with hardening steel
- Hardened 0,6 - 0,8 mm depth
- Hardened, tempered, burnished
- Hardness HRC 58 ± 2, strenght 800-1000 N/mm²
- Runout accuracy 0,005
- Cylindricity 0,003



**Fornite con
apposito contenitore**
Supplied with
suitable case

BT

MANDRINI PER PUNTE AD INSERTI
INDEXABLE DRILL HOLDERS

FORMA AD (JD)

Balanced G 6,3
12.000 rpm



FORMA AD

TIPO	Art.	D	H	E	L	
BT 40 - D. 16 P	8574	16	75	36	54	0403
BT 40 - D. 20 P	8575	20	75	40	54	0403
BT 40 - D. 25 P	8576	25	80	45	59	0417
BT 40 - D. 32 P	8577	32	85	52	63	0417
BT 50 - D. 16 P	8721	16	80	36	54	0403
BT 50 - D. 20 P	8722	20	80	40	54	0403
BT 50 - D. 25 P	8723	25	90	45	59	0417
BT 50 - D. 32 P	8724	32	90	52	63	0417
BT 50 - D. 40 P	8725	40	100	60	73	0493

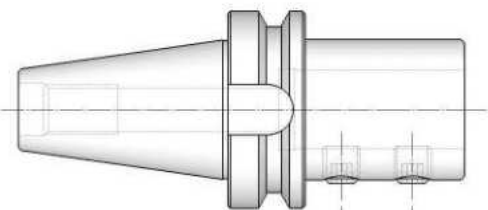
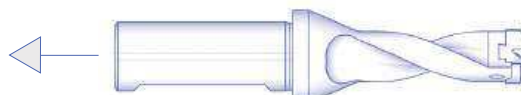
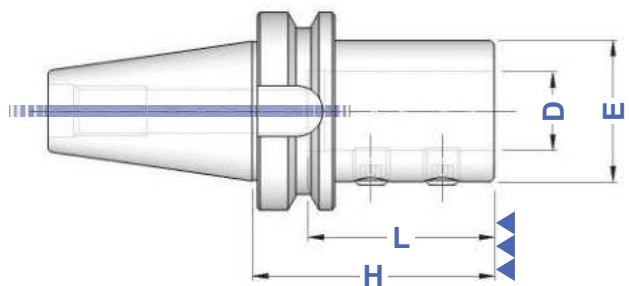

n.2 grani di bloccaggio
two locking screws



Tamponi Pulitori pag. 243
Taper Cleaners page 243



Codoli di Aggancio pag. 221
Pull Studs page 221



Smontaconi Orientabili pag. 240
Orientable Tightening Fixtures page 240

BT

PORTAFRESE WELDON TIPO EXTRACORTO
SHORT TYPE END MILL HOLDERS

FORMA AD (JD)

FORMA AD+B (JD/JF)

Balanced G 6,3
12.000 rpm





TIPO	FORMA AD	FORMA AD+B	D	H	E	Fig.	 	
	Art.	Art.					G1	G2
BT 40 - WE 12/H 35	3053	—	12	35	44	1	4973	—
BT 40 - WE 16/H 35	3054	5122	16	35	44	1	0068	—
BT 40 - WE 20/H 35	3055	5123	20	35	44	1	0261	—
BT 40 - WE 25/H 35	3056	—	25	35	44	1	0082	—
BT 40 - WE 25/H 60	4629	4554	25	60	49	2	0082	0076
BT 40 - WE 32/H 40	3069	—	32	40	44	1	0074	—
BT 40 - WE 32/H 70	4630	4556	32	70	72	2	0082	4977
BT 50 - WE 16/H 44	3057	5125	16	44	70	1	4974	—
BT 50 - WE 20/H 44	3058	5126	20	44	70	1	4975	—
BT 50 - WE 25/H 44	3059	5127	25	44	70	1	4976	—
BT 50 - WE 32/H 44	3060	5128	32	44	70	1	4977	—
BT 50 - WE 40/H 44	8468	8473	40	44	70	1	0259	—

Figura 1

1 grano di bloccaggio
single locking screw



Figura 2

2 grani di bloccaggio
two locking screws

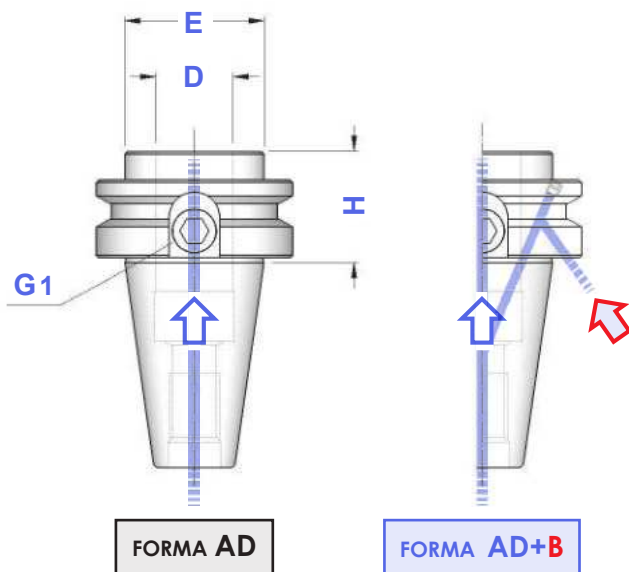
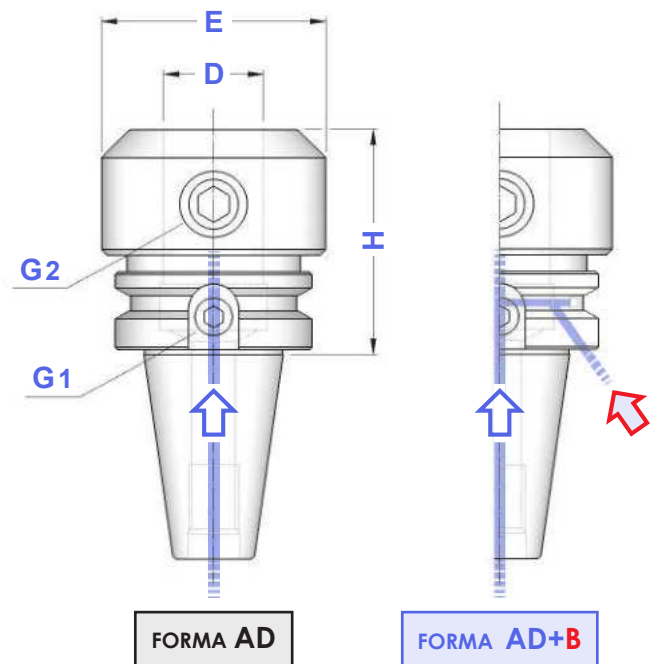

BT	PORTAFRESE WELDON <i>END MILL HOLDERS FOR DIN 1835-B SHANKS</i>	FORMA AD (JD)
		FORMA AD+B (JD/JF)

Balanced	G 6,3
≤ H130	12.000 rpm
≥ H160	8.000 rpm



WE6 ÷ WE20
1 grano
1 screw



WE25 ÷ WE50
2 grani
2 screws

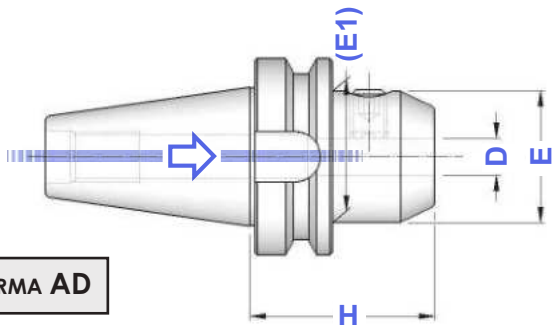

FORMA AD

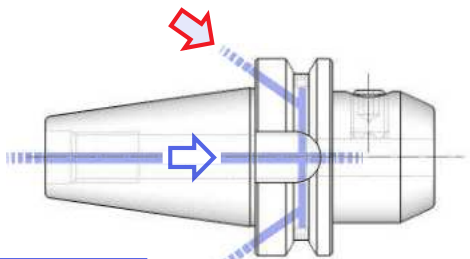

FORMA AD+B

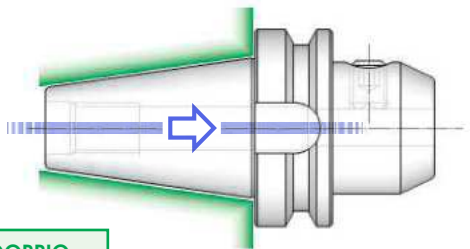

**DOPPIO CONTATTO
FORMA AD**

TIPO	FORMA AD	FORMA AD+B	DOPPIO CONTATTO	D	H	E	
	Art.	Art.	Art.				
BT 30 - WE 6/H 50	3740	—	10636	6	50	25	4970
BT 30 - WE 8/H 50	3741	—	10637	8	50	28	4971
BT 30 - WE 10/H 50	3742	—	10638	10	50	35	4972
BT 30 - WE 12/H 55	3743	—	10639	12	55	42	4973
BT 30 - WE 16/H 63	3744	—	10640	16	63	48	4974
BT 30 - WE 20/H 70	3299	—	10641	20	70	52	4975
BT 40 - WE 6/H 50	3752	4909	10642	6	50	25	4970
BT 40 - WE 6/H 100	5057	5863	10643		100		
BT 40 - WE 6/H 130	8004	8021	—		130		
BT 40 - WE 6/H 160	5564	5864	—		160		
BT 40 - WE 6/H 200	4253	4391	—		200		
BT 40 - WE 8/H 50	3753	4910	10647	8	50	28	4971
BT 40 - WE 8/H 100	5058	5865	10648		100		
BT 40 - WE 8/H 130	8005	8022	—		130		
BT 40 - WE 8/H 160	5565	5866	—		160		
BT 40 - WE 8/H 200	4254	4396	—		200		
BT 40 - WE 10/H 63	3754	4911	10652	10	63	35	4972
BT 40 - WE 10/H 100	5059	5867	10653		100		
BT 40 - WE 10/H 130	8006	8023	—		130		
BT 40 - WE 10/H 160	5566	5868	—		160		
BT 40 - WE 10/H 200	4255	4397	—		200		
BT 40 - WE 12/H 63	3755	4912	10657	12	63	42	4973
BT 40 - WE 12/H 100	5060	5869	10658		100		
BT 40 - WE 12/H 130	8007	8024	—		130		
BT 40 - WE 12/H 160	5567	5870	—		160		
BT 40 - WE 12/H 200	4262	4401	—		200		
BT 40 - WE 14/H 63	4557	4913	10662	14	63	44	4973
BT 40 - WE 14/H 100	5061	5871	—		100		
BT 40 - WE 14/H 130	8008	8025	—		130		
BT 40 - WE 14/H 160	4268	4432	—		160		
BT 40 - WE 14/H 200	4269	4433	—		200		
BT 40 - WE 16/H 63	3756	4914	10667	16	63	48	4974
BT 40 - WE 16/H 100	5062	5872	10668		100		
BT 40 - WE 16/H 130	8009	8026	—		130		
BT 40 - WE 16/H 160	5063	5873	—		160		
BT 40 - WE 16/H 200	4270	4434	—		200		
BT 40 - WE 18/H 63	4558	4915	10672	18	63	50	4974
BT 40 - WE 18/H 100	5064	5874	—		100		
BT 40 - WE 18/H 130	8010	8027	—		130		
BT 40 - WE 18/H 160	4271	4435	—		160		
BT 40 - WE 18/H 200	4272	4436	—		200		
BT 40 - WE 20/H 63	3757	4916	10677	20	63	52	4975
BT 40 - WE 20/H 100	5066	5875	10678		100		
BT 40 - WE 20/H 130	5067	4437	—		130		
BT 40 - WE 20/H 160	5068	5876	—		160		
BT 40 - WE 20/H 200	4274	4446	—		200		
BT 40 - WE 25/H 90	3758	4917	10682	25	90	65	4976
BT 40 - WE 25/H 130	5069	4939	—		130		
BT 40 - WE 25/H 160	5070	4448	—		160		
BT 40 - WE 25/H 200	4358	4479	—		200		
BT 40 - WE 32/H 100	3759	4918	10686	32	100	72	4977
BT 40 - WE 32/H 130	5071	4480	—		130		
BT 40 - WE 32/H 160	5072	4481	—		160		
BT 40 - WE 32/H 200	4359	4482	—		200		
BT 40 - WE 40/H 105	4559	4919	10690	40	105	80	4977

segue

➔ segue
continue

Balanced G 6,3
8.000 rpm



WE6 ÷ WE20
1 grano
1 screw



WE25 ÷ WE50
2 grani
2 screws

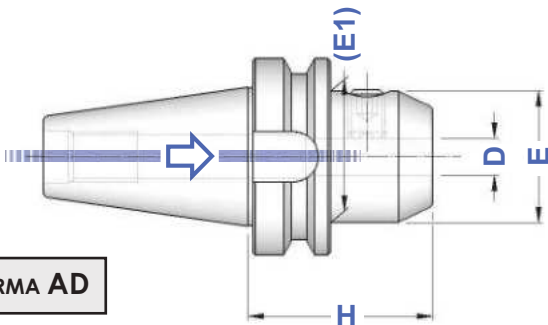

FORMA AD

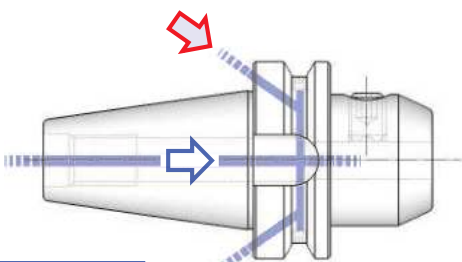

FORMA AD+B

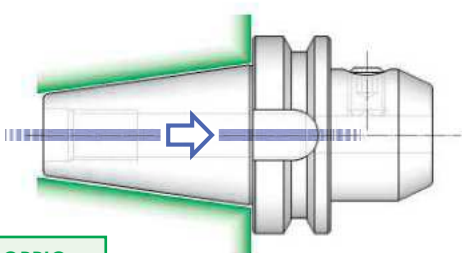

DOPPIO
CONTATTO
FORMA AD

TIPO	FORMA	FORMA	DOPPIO	D	H	E	
	AD	AD+B	CONTATTO				
BT 50 - WE 6/H 63	3295	4920	10691	6	63	25	4970
BT 50 - WE 6/H 100	5073	5877	—		100		
BT 50 - WE 6/H 130	8011	8028	—		130		
BT 50 - WE 6/H 160	5568	5878	—		160		
BT 50 - WE 6/H 200	4360	4485	—		200		
BT 50 - WE 8/H 63	3769	4921	10696	8	63	28	4971
BT 50 - WE 8/H 100	5074	5879	—		100		
BT 50 - WE 8/H 130	8012	8029	—		130		
BT 50 - WE 8/H 160	5569	5880	—		160		
BT 50 - WE 8/H 200	4361	4497	—		200		
BT 50 - WE 10/H 70	3770	4922	10701	10	70	35	4972
BT 50 - WE 10/H 100	5075	5907	—		100		
BT 50 - WE 10/H 130	8013	8030	—		130		
BT 50 - WE 10/H 160	5572	5908	—		160		
BT 50 - WE 10/H 200	4366	4498	—		200		
BT 50 - WE 12/H 80	3771	4923	10706	12	80	42	4973
BT 50 - WE 12/H 100	5574	5912	—		100		
BT 50 - WE 12/H 130	8014	8031	—		130		
BT 50 - WE 12/H 160	5076	5909	—		160		
BT 50 - WE 12/H 200	4370	4499	—		200		
BT 50 - WE 14/H 80	4560	4924	10711	14	80	44	4973
BT 50 - WE 14/H 100	4371	4500	—		100		
BT 50 - WE 14/H 130	8015	8032	—		130		
BT 50 - WE 14/H 160	4375	4502	—		160		
BT 50 - WE 14/H 200	4376	4503	—		200		
BT 50 - WE 16/H 80	3772	4925	10716	16	80	48	4974
BT 50 - WE 16/H 100	5575	5913	—		100		
BT 50 - WE 16/H 130	8016	8033	—		130		
BT 50 - WE 16/H 160	5078	5910	—		160		
BT 50 - WE 16/H 200	4380	4523	—		200		
BT 50 - WE 18/H 80	4561	4926	10721	18	80	50	4974
BT 50 - WE 18/H 100	4381	4524	—		100		
BT 50 - WE 18/H 130	8017	8034	—		130		
BT 50 - WE 18/H 160	4382	4525	—		160		
BT 50 - WE 18/H 200	4384	4526	—		200		
BT 50 - WE 20/H 80	3773	4927	10726	20	80	52	4975
BT 50 - WE 20/H 100	5576	5914	—		100		
BT 50 - WE 20/H 130	8018	8035	—		130		
BT 50 - WE 20/H 160	5080	5911	—		160		
BT 50 - WE 20/H 200	4386	4527	—		200		
BT 50 - WE 25/H 100	3774	4928	10731	25	100	65	4976
BT 50 - WE 25/H 130	8019	8036	—		130		
BT 50 - WE 25/H 160	5082	5915	—		160		
BT 50 - WE 25/H 200	4388	4528	—		200		
BT 50 - WE 32/H 105	3775	4929	10735	32	105	72	4977
BT 50 - WE 32/H 130	8020	8037	—		130		
BT 50 - WE 32/H 160	5083	5916	—		160		
BT 50 - WE 32/H 200	4389	4529	—		200		
BT 50 - WE 40/H 120	3776	4930	10739	40	120	80	4977
BT 50 - WE 40/H 160	5085	5917	—		160		
BT 50 - WE 40/H 200	4390	4530	—		200		
BT 50 - WE 50/H 125	3777	4552	—	50	125	100	4978



BT

**PORTAFRESE WELDON CON
CANALI DI REFRIGERAZIONE**

END MILL HOLDERS with COOLANT CHANNELS for DIN 1835B SHANKS

FORMA AD+B (JD/JF)

Balanced G 6,3
12.000 rpm

**FORMA
AD+B**



WEC 6 ÷ WEC 20
1 grano
1 screw



WEC 25 ÷ WEC 40
2 grani
2 screws

TIPO	Art.	D	H	E	
BT 40 - WEC 6/H 50	7872	6	50	25	4970
BT 40 - WEC 8/H 50	7873	8	50	28	4971
BT 40 - WEC 10/H 63	7874	10	63	35	4972
BT 40 - WEC 12/H 63	7875	12	63	42	4973
BT 40 - WEC 14/H 63	7876	14	63	44	4973
BT 40 - WEC 16/H 63	7877	16	63	48	4974
BT 40 - WEC 18/H 63	7878	18	63	50	4974
BT 40 - WEC 20/H 63	7879	20	63	52	4975
BT 40 - WEC 25/H 90	7880	25	90	65	4976
BT 40 - WEC 32/H 100	7881	32	100	72	4977
BT 40 - WEC 40/H 105	7882	40	105	80	4977
BT 50 - WEC 6/H 63	7883	6	63	25	4970
BT 50 - WEC 8/H 63	7884	8	63	28	4971
BT 50 - WEC 10/H 70	7885	10	70	35	4972
BT 50 - WEC 12/H 80	7886	12	80	42	4973
BT 50 - WEC 14/H 80	7887	14	80	44	4973
BT 50 - WEC 16/H 80	7888	16	80	48	4974
BT 50 - WEC 18/H 80	7889	18	80	50	4974
BT 50 - WEC 20/H 80	7890	20	80	52	4975
BT 50 - WEC 25/H 100	7891	25	100	65	4976
BT 50 - WEC 32/H 105	7892	32	105	72	4977
BT 50 - WEC 40/H 120	7893	40	120	80	4977

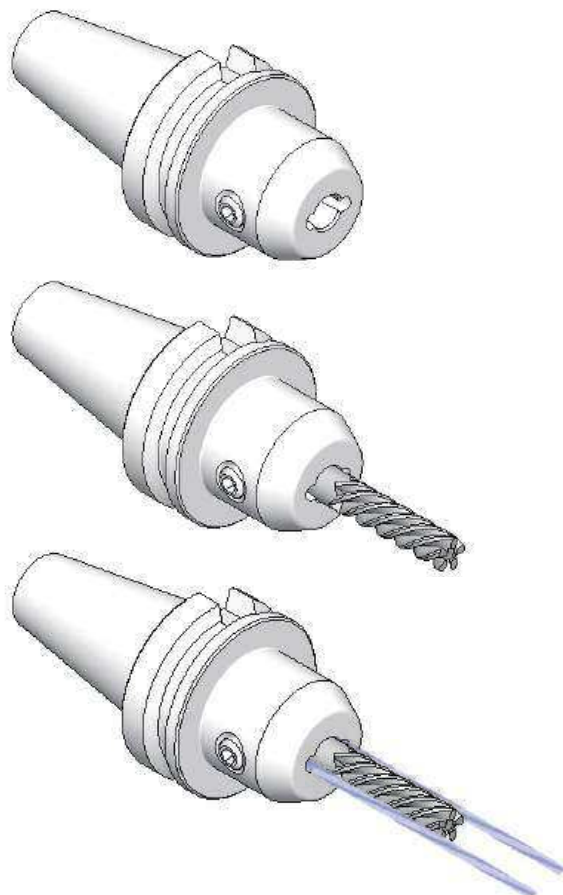
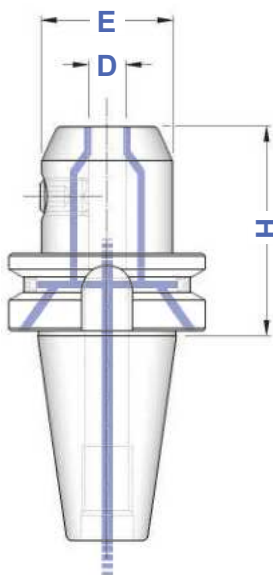

BT

MANDRINI PER UTENSILI ATTACCO WHISTLE NOTCH
END MILL HOLDERS FOR DIN 1835-E SHANKS

FORMA AD+B (JD/JF)

Balanced G 6,3
12.000 rpm

FORMA AD+B



WN 6 ÷ WN 20
1 grano
1 screw



WN 25 ÷ WN 40
2 grani
2 screws

TIPO	Art.	D	H	E	
BT 40 - WN 6 / H 50	4666	6	50	25	4970
BT 40 - WN 8 / H 50	4667	8	50	28	4971
BT 40 - WN 10 / H 63	4668	10	63	35	4972
BT 40 - WN 12 / H 63	4669	12	63	42	4973
BT 40 - WN 14 / H 63	4670	14	63	44	4973
BT 40 - WN 16 / H 63	4671	16	63	48	4974
BT 40 - WN 18 / H 63	4672	18	63	50	4974
BT 40 - WN 20 / H 63	4673	20	63	52	4975
BT 40 - WN 25 / H 90	4674	25	90	65	4976
BT 40 - WN 32 / H 100	4675	32	100	72	4977
BT 40 - WN 40 / H 105	4692	40	105	80	4977
BT 50 - WN 6 / H 63	4676	6	63	25	4970
BT 50 - WN 8 / H 63	4677	8	63	28	4971
BT 50 - WN 10 / H 70	4678	10	70	35	4972
BT 50 - WN 12 / H 80	4679	12	80	42	4973
BT 50 - WN 14 / H 80	4680	14	80	44	4973
BT 50 - WN 16 / H 80	4681	16	80	48	4974
BT 50 - WN 18 / H 80	4682	18	80	50	4974
BT 50 - WN 20 / H 80	4683	20	80	52	4975
BT 50 - WN 25 / H 100	4684	25	100	65	4976
BT 50 - WN 32 / H 105	4685	32	105	72	4977
BT 50 - WN 40 / H 120	4686	40	120	80	4977

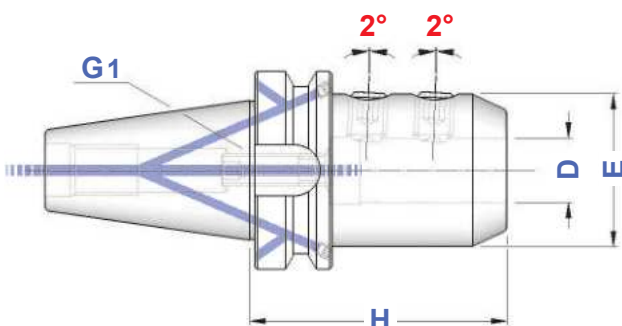
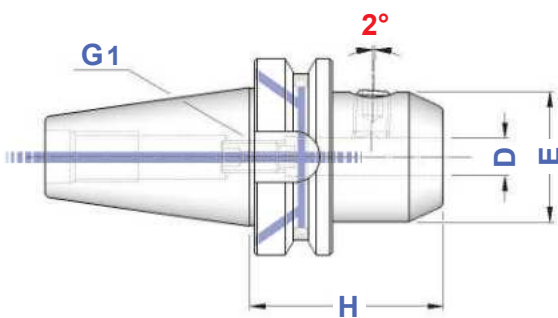
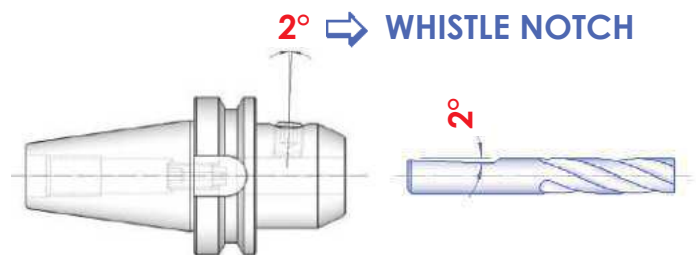

GRANO di PRESETTAGGIO con foro passante (G1)
PPRESETTING SCREW through hole (G1)

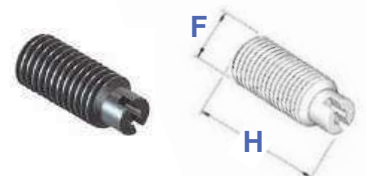

Art.	F x H	Passo
0233	M 5 x 16	0,8
0235	M 6 x 16	1
0238	M 8 x 20	1,25
0240	M 10 x 25	1,5
0245	M 12 x 30	1,75
1226	M 16 x 20	2
0212	M 20 x 20	2,5
0247	M 20 x 30	2,5

BT	RIDUZIONI A CONO MORSE PER PUNTE MT ADAPTERS FOR TWIST DRILLS	FORMA AD (JD)
----	---	----------------------

Balanced G 6,3
8.000 rpm

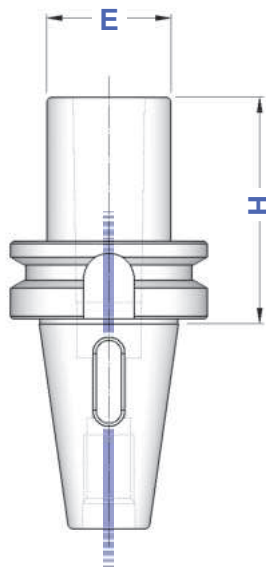

FORMA AD

TIPO	Art.	CM	H	E
BT 30 - CM 1 PUNTE	8346	1	50	25
BT 30 - CM 2 PUNTE	3796	2	60	32
BT 30 - CM 3 PUNTE	3883	3	80	40
BT 40 - CM 1 PUNTE	8347	1	50	25
BT 40 - CM 2 PUNTE	8349	2	60	32
BT 40 - CM 3 PUNTE	3783	3	75	40
BT 40 - CM 4 PUNTE	3784	4	95	48
BT 50 - CM 1 PUNTE	8352	1	45	25
BT 50 - CM 2 PUNTE	8354	2	60	32
BT 50 - CM 3 PUNTE	8356	3	65	40
BT 50 - CM 4 PUNTE	3793	4	95	48
BT 50 - CM 5 PUNTE	3794	5	105	63



BT	RIDUZIONI A CONO MORSE PER FRESE MT ADAPTERS FOR MILLING CUTTERS	FORMA A (J)
----	--	--------------------

Balanced G 6,3
8.000 rpm

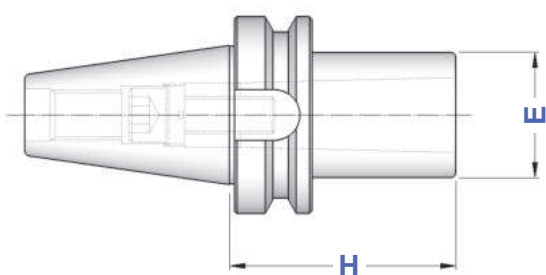

FORMA A

TIPO	Art.	CM	H	E		
BT 30 - CM 2 FRESE	3882	2	60	32	7422	4569
BT 30 - CM 3 FRESE	3884	3	80	40	7423	4570
BT 40 - CM 2 FRESE	3886	2	50	32	7422	4569
BT 40 - CM 3 FRESE	3887	3	75	40	7423	4570
BT 40 - CM 4 FRESE	3888	4	95	48	7424	4571
BT 50 - CM 2 FRESE	3801	2	50	32	7422	4569
BT 50 - CM 3 FRESE	2933	3	65	40	7423	4570
BT 50 - CM 4 FRESE	3890	4	95	48	7424	4571
BT 50 - CM 5 FRESE	3891	5	120	63	7425	4572



BT

**RIDUZIONI A CONO MORSE PUNTE + FRESE
COMBINATE**

FORMA A (J)

COMBI MT ADAPTERS: TWIST DRILLS + MILLING CUTTERS

Balanced G 6,3
8.000 rpm

**PUNTE
+
FRESE**

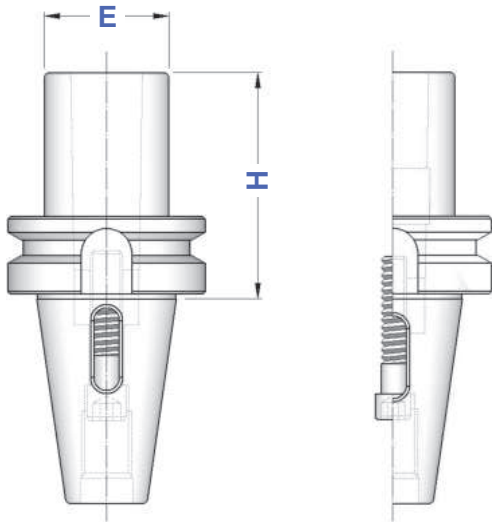

TIPO	Art.	CM	H	E
BT 40 - CM 1 P+F	3781	1	50	25
BT 40 - CM 2 P+F	3782	2	60	32
BT 40 - CM 3 P+F	8360	3	75	40
BT 50 - CM 1 P+F	3790	1	45	25
BT 50 - CM 2 P+F	3791	2	60	32
BT 50 - CM 3 P+F	3792	3	65	40
BT 50 - CM 4 P+F	8361	4	95	48

COMBINATE PUNTE + FRESE
COMBI TWIST DRILL + MILLING CUTTERS



BT

**RIDUZIONI A CONO MORSE PER PUNTE E PUNTE + FRESE
TIPO PROLUNGATO**

FORMA A (J)

EXTENDED MT ADAPTERS: TWIST DRILLS, TWIST DRILLS + MILLING CUTTERS

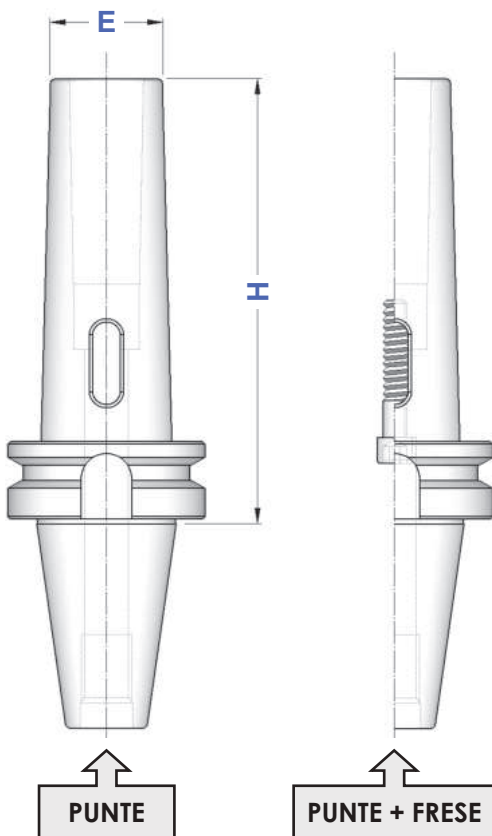

**PUNTE
+
FRESE**

TIPO	Art.	Art.	CM	H	E
BT 40 - CM 1	8348	4258	1	115	18
BT 40 - CM 2	8350	4259	2	120	25
BT 40 - CM 3	8351	4260	3	140	33
BT 40 - CM 4	4261	—	4	165	40
BT 50 - CM 1	8353	4263	1	120	18
BT 50 - CM 2	8355	4264	2	140	25
BT 50 - CM 3	8357	4265	3	150	33
BT 50 - CM 4	8358	4266	4	180	40
BT 50 - CM 5	8359	—	5	220	55



BT

PORTAFRESE FISSI
FACE MILL HOLDERS

FORMA A (J)

FORMA AD+B (JD/JF)

Balanced G 6,3
8.000 rpm

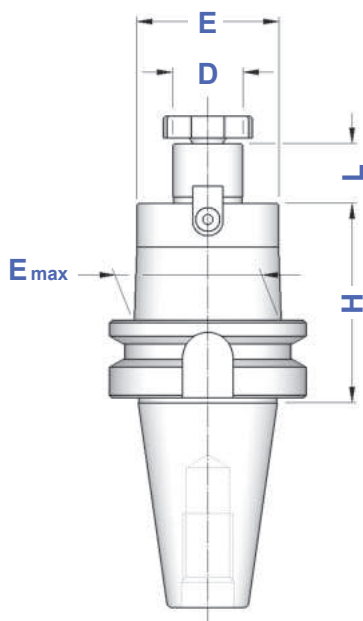

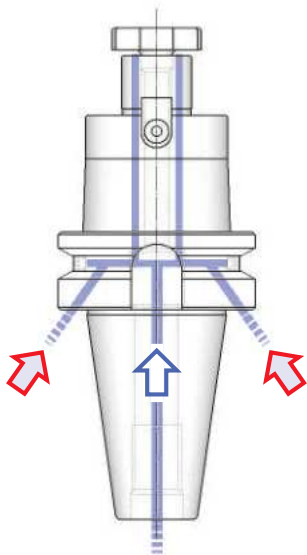

FORMA A



FORMA AD+B

FORMA A
FORMA AD+B

TIPO	Art.	Art.	D	L	E	E _{max}		
BT 30 - D.13 FISSO / H 35	8412	—	13	12	28	—	0482	—
BT 30 - D.16 FISSO / H 35	4152	—	16	17	38	—	4985	4562
BT 30 - D.22 FISSO / H 40	4154	—	22	19	48	—	4986	4563
BT 30 - D.27 FISSO / H 40	4156	—	27	21	58	—	4987	4564
BT 40 - D.16 FISSO / H 45	4161	5881	16	17	38	—	4985	4562
BT 40 - D.16 FISSO / H 100	5578	5882						
BT 40 - D.16 FISSO / H 130	9420	9430						
BT 40 - D.16 FISSO / H 160	8415	8438						
BT 40 - D.16 FISSO / H 200	8416	8439						
BT 40 - D.22 FISSO / H 45	4644	5883	22	19	48	—	4986	4563
BT 40 - D.22 FISSO / H 100	5588	5884						
BT 40 - D.22 FISSO / H 130	9421	9431						
BT 40 - D.22 FISSO / H 160	5589	8440						
BT 40 - D.22 FISSO / H 200	8417	8441						
BT 40 - D.27 FISSO / H 45	4645	5885	27	21	58	—	4987	4564
BT 40 - D.27 FISSO / H 100	5590	5886						
BT 40 - D.27 FISSO / H 130	9422	9432						
BT 40 - D.27 FISSO / H 160	5591	8442						
BT 40 - D.27 FISSO / H 200	8418	8443						
BT 40 - D.32 FISSO / H 50	4646	5887	32	24	78	—	4988	4565
BT 40 - D.32 FISSO / H 100	5592	5888						
BT 40 - D.32 FISSO / H 160	8419	8444						
BT 40 - D.40 FISSO / H 55	4647	5889	40	27	88	—	4989	4566
BT 40 - D.40 FISSO / H 100	8420	8445						
BT 40 - D.40 FISSO / H 160	8421	8446						
BT 50 - D.16 FISSO / H 60	4648	5890	16	17	38	—	4985	4562
BT 50 - D.16 FISSO / H 100	5593	5891						
BT 50 - D.16 FISSO / H 130	9425	9435						
BT 50 - D.16 FISSO / H 160	8422	8447						
BT 50 - D.16 FISSO / H 200	8423	8448						
BT 50 - D.22 FISSO / H 60	4172	5892	22	19	48	—	4986	4563
BT 50 - D.22 FISSO / H 100	5659	5893						
BT 50 - D.22 FISSO / H 130	9426	9436						
BT 50 - D.22 FISSO / H 160	5660	8449						
BT 50 - D.22 FISSO / H 200	8424	8450						
BT 50 - D.22 FISSO / H 250	8425	8451						
BT 50 - D.22 FISSO / H 300	8426	8452						
BT 50 - D.27 FISSO / H 60	4649	5894	27	21	58	—	4987	4564
BT 50 - D.27 FISSO / H 100	5666	5895						
BT 50 - D.27 FISSO / H 130	9427	9437						
BT 50 - D.27 FISSO / H 160	5667	8453						
BT 50 - D.27 FISSO / H 200	8427	8454						
BT 50 - D.27 FISSO / H 250	8428	8455						
BT 50 - D.27 FISSO / H 300	8429	8456						
BT 50 - D.32 FISSO / H 60	4650	5896	32	24	78	—	4988	4565
BT 50 - D.32 FISSO / H 100	5669	5897						
BT 50 - D.32 FISSO / H 130	9428	9438						
BT 50 - D.32 FISSO / H 160	8430	8457						
BT 50 - D.32 FISSO / H 200	8431	8458						
BT 50 - D.32 FISSO / H 250	8432	8459						
BT 50 - D.32 FISSO / H 300	8433	8460						
BT 50 - D.40 FISSO / H 60	4651	5898	40	27	88	—	4989	4566
BT 50 - D.40 FISSO / H 100	5676	5899						
BT 50 - D.40 FISSO / H 160	8434	8461						
BT 50 - D.40 FISSO / H 200	8435	8462						



BT

PORTAFRESE FISSI - DOPPIO CONTATTO
DOUBLE CONTACT FACE MILL HOLDERS

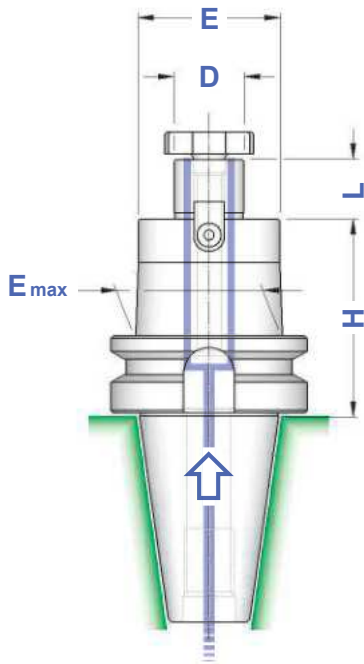

FORMA AD (JD)

Balanced G 6,3
8.000 rpm



**DOPPIO
CONTATTO
FORMA AD**

**DOPPIO
CONTATTO**

TIPO	Art.	D	L	E	E _{max}		
BT 30 - D.16 FISSO / H 35	10744	16	17	38	-	4985	4562
BT 30 - D.22 FISSO / H 45	10745	22	19	48	-	4986	4563
BT 30 - D.27 FISSO / H 45	10746	27	21	58	-	4987	4564
BT 40 - D.16 FISSO / H 45	10747	16	17	38	-	4985	4562
BT 40 - D.16 FISSO / H 100	10748						
BT 40 - D.16 FISSO / H 130	10749						
BT 40 - D.16 FISSO / H 160	10750						
BT 40 - D.22 FISSO / H 45	10752	22	19	48	-	4986	4563
BT 40 - D.22 FISSO / H 100	10753			46	48		
BT 40 - D.22 FISSO / H 130	10754						
BT 40 - D.22 FISSO / H 160	10755						
BT 40 - D.27 FISSO / H 45	10757	27	21	58	-	4987	4564
BT 40 - D.27 FISSO / H 100	10758			48	-		
BT 40 - D.32 FISSO / H 50	10762	32	24	78	-	4988	4565
BT 40 - D.40 FISSO / H 55	10765	40	27	88	-	4989	4566
BT 50 - D.16 FISSO / H 60	10768	16	17	38	-	4985	4562
BT 50 - D.22 FISSO / H 60	10773	22	19	48	-	4986	4563
BT 50 - D.27 FISSO / H 60	10780	27	21	58	-	4987	4564
BT 50 - D.32 FISSO / H 60	10787	32	24	78	-	4988	4565
BT 50 - D.40 FISSO / H 60	10794	40	27	88	-	4989	4566



p.255



p.258



p.254



p.254



Codoli di Aggancio
pag. 221
Pull Studs
page 221



BT

ATTACCHI PER FRESE AD INSERTI
FACE MILL HOLDERS FOR FACE MILLING CUTTERS

FORMA A (J)

Balanced G 6,3
8.000 rpm

FORMA A



TIPO	Art.	D	H	E	C	F	T	
BT 40 - D. 40 FM	4186	40	60	89	66,7	M12	15,9	4989
BT 50 - D. 40 FM	4187	40	70	89	66,7	M12	15,9	4989
BT 50 - D. 60 FM	4188	60	80	129	101,6	M16	25,4	—

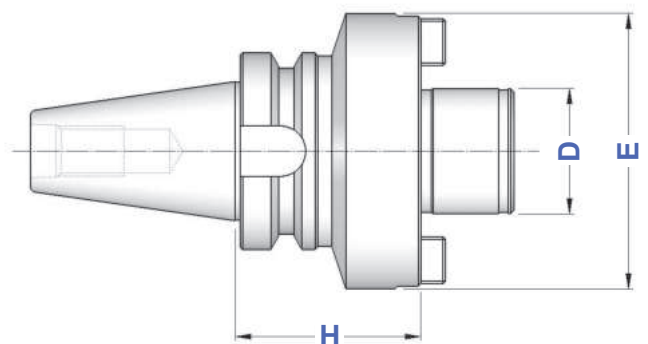
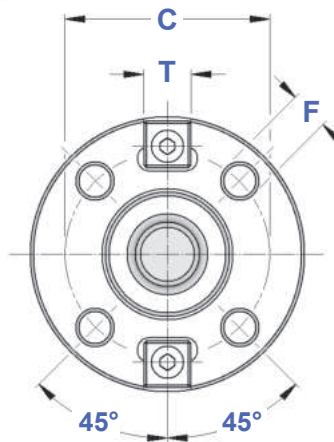

BT

PORTAFRESE CON CHIAVETTA DI TRASCINAMENTO
MILL HOLDERS WITH FEATHER KEY

FORMA A (J)

FORMA A



TIPO	Art.	D	H	L	E			
BT 40 - D. 16 CHT	8503	16	52	30	28	0147	4985	4562
BT 40 - D. 22 CHT	8504	22	52	40	36	0148	4986	4563
BT 40 - D. 27 CHT	8505	27	52	60	43	0149	4987	4564
BT 40 - D. 32 CHT	8506	32	52	60	48	0150	4988	4565
BT 40 - D. 40 CHT	8507	40	52	60	56	0151	4989	4566

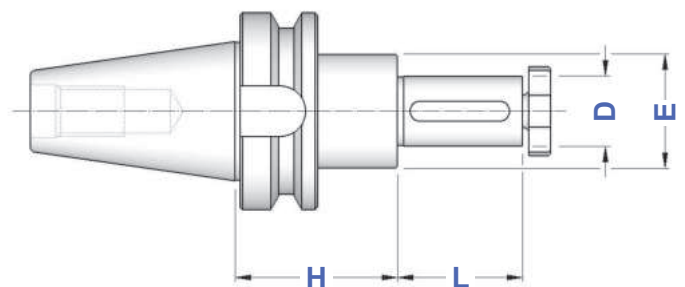

BT

PORTAFRESE COMBINATI
DIN 6358 COMBI SHELL MILL HOLDERS

FORMA A (J)

Balanced G 6,3
8.000 rpm



TIPO	FORMA A		D	L1	L	E	E _{max}				
	Art.										
BT30 - D.16 C/H 50	3797		16	27	17	32	-	4090	0115	4985	4562
BT30 - D.22 C/H 50	3798		22	31	19	40	-	4091	0116	4986	4563
BT30 - D.27 C/H 55	3943		27	33	21	48	-	4092	0122	4987	4564
BT40 - D.16 C/H 55	3802		16	27	17	32	-	4090	0115	4985	4562
BT40 - D.16 C/H100	4113										
BT40 - D.16 C/H160	8483						44				
BT40 - D.22 C/H 55	3803		22	31	19	40	-	4091	0116	4986	4563
BT40 - D.22 C/H100	4114										
BT40 - D.22 C/H160	8484						47				
BT40 - D.27 C/H 55	3804		27	33	21	48	-	4092	0122	4987	4564
BT40 - D.27 C/H100	4115										
BT40 - D.27 C/H160	8485						55				
BT40 - D.32 C/H 60	3805		32	38	24	58	-	4093	0125	4988	4565
BT40 - D.32 C/H100	4116										
BT40 - D.32 C/H160	8486										
BT40 - D.40 C/H 60	3806		40	41	27	70	-	4094	0133	4989	4566
BT40 - D.40 C/H100	3810										
BT50 - D.16 C/H 70	3812		16	27	17	32	-	4090	0115	4985	4562
BT50 - D.16 C/H100	4117						44				
BT50 - D.22 C/H 70	3813		22	31	19	40	-	4091	0116	4986	4563
BT50 - D.22 C/H100	4118						50				
BT50 - D.27 C/H 70	3814		27	33	21	48	-	4092	0122	4987	4564
BT50 - D.27 C/H100	4119						60				
BT50 - D.32 C/H 70	3815		32	38	24	58	-	4093	0125	4988	4565
BT50 - D.32 C/H100	4120										
BT50 - D.40 C/H 70	3816		40	41	27	70	-	4094	0133	4989	4566
BT50 - D.40 C/H100	4121										

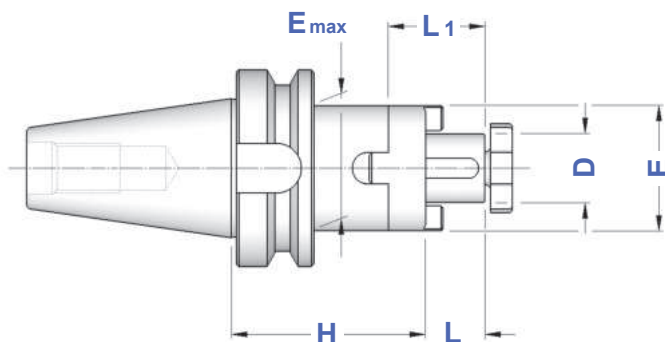

BT

MANDRINI PER FRESE CON ATTACCO FILETTATO
CHUCKS FOR MILLING CUTTERS WITH THREADED SHANK

FORMA AD (JD)

Balanced G 6,3
12.000 rpm

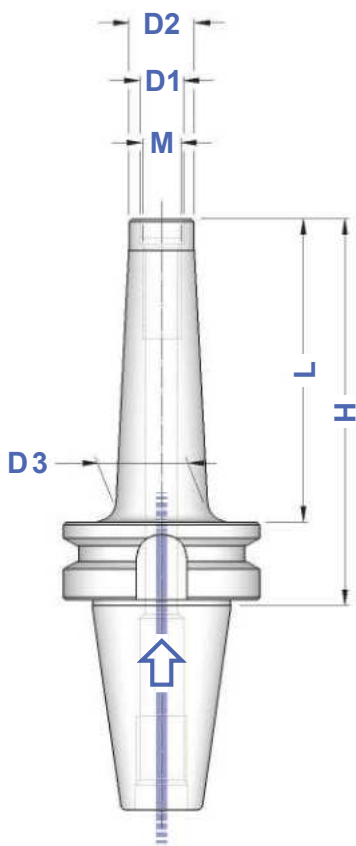

FORMA AD

FORMA AD

TIPO	Art.	M	D1	D2	D3	H	L
BT 40 - M 8 / H 55	7827	M 8	8,5	13	15	55	28
BT 40 - M 8 / H 77	7828				23	77	50
BT 40 - M 8 / H 102	7829				23	102	75
BT 40 - M 8 / H 127	7830				25	127	100
BT 40 - M 10 / H 55	7831	M 10	10,5	18	20	55	28
BT 40 - M 10 / H 77	7832				23	77	50
BT 40 - M 10 / H 102	7833				28	102	75
BT 40 - M 10 / H 127	7834				32	127	100
BT 40 - M 12 / H 55	7835	M 12	12,5	21	24	55	28
BT 40 - M 12 / H 77	7836				24	77	50
BT 40 - M 12 / H 102	7837				31	102	75
BT 40 - M 12 / H 127	7838				33	127	100
BT 40 - M 16 / H 55	7839	M 16	17,0	29	32	55	28
BT 40 - M 16 / H 77	7840				34	77	50
BT 40 - M 16 / H 102	7841				34	102	75
BT 40 - M 16 / H 127	7842				36	127	100
BT 40 - M 16 / H 152	7843	40	152	125			
BT 50 - M 12 / H 88	7844	M 12	12,5	21	24	88	50
BT 50 - M 12 / H 138	7845				33	138	100
BT 50 - M 12 / H 188	7846				40	188	150
BT 50 - M 12 / H 254	8719				42	254	216
BT 50 - M 16 / H 88	7847	M 16	17,0	29	34	88	50
BT 50 - M 16 / H 138	7848				36	138	100
BT 50 - M 16 / H 188	7849				42,5	188	150
BT 50 - M 16 / H 254	8720				44	254	216

Prolunghe, Riduzioni, Portapinze ER con attacco filettato a pag. 46

Extensions, Reductions, ER Collet Chucks with threaded shank at page 46



BT

**MASCHIATORI A CAMBIO RAPIDO CON
DOPPIA COMPENSAZIONE**
DOUBLE COMPENSATION QUICK CHANGE TAPPING CHUCKS

FORMA A (J)



**FORMA
A**

TIPO	Art.	H	E	B	COMPENSAZIONE	
BT 30 - B.1	2863	63	38	19	- 7,5 + 7,5	M 3 ÷ M 12 (*M18)
BT 30 - B.2	2865	96	55	31	- 12,5 + 12,5	M 6 ÷ M 20 (*M30)
BT 40 - B.1	3524	68	38	19	- 7,5 + 7,5	M 3 ÷ M 12 (*M18)
BT 40 - B.2	3525	93	55	31	- 12,5 + 12,5	M 6 ÷ M 20 (*M30)
BT 40 - B.3	3526	164	79	48	- 20,0 + 20,0	M14 ÷ M 33 (*M48)
BT 50 - B.1	3028	80	38	19	- 7,5 + 7,5	M 3 ÷ M 12 (*M18)
BT 50 - B.2	3530	102	55	31	- 12,5 + 12,5	M 6 ÷ M 20 (*M30)
BT 50 - B.3	3531	133	79	48	- 20,0 + 20,0	M14 ÷ M 33 (*M48)



* Bussole con GRANI
Adapters with SCREWS

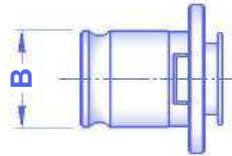
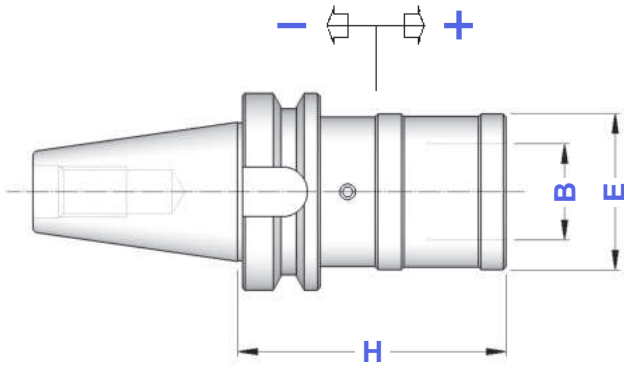

BT

**MASCHIATORI A CAMBIO RAPIDO
SENZA COMPENSAZIONE**
QUICK CHANGE TAPPING CHUCKS WITHOUT COMPENSATION

FORMA AD (JD)



**FORMA
AD**

TIPO	Art.	H	E	B	
BT 40 - B.1 FISSO	4951	67	33	19	M 3 ÷ M 12 (*M18)
BT 40 - B.2 FISSO	4952	90	50	31	M 6 ÷ M 20 (*M30)
BT 40 - B.3 FISSO	5711	117	72	48	M14 ÷ M 33 (*M48)
BT 50 - B.1 FISSO	2999	78	33	19	M 3 ÷ M 12 (*M18)
BT 50 - B.2 FISSO	4953	101	50	31	M 6 ÷ M 20 (*M30)
BT 50 - B.3 FISSO	5712	125	72	48	M14 ÷ M 33 (*M48)

* Bussole con GRANI
Adapters with SCREWS

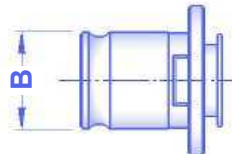
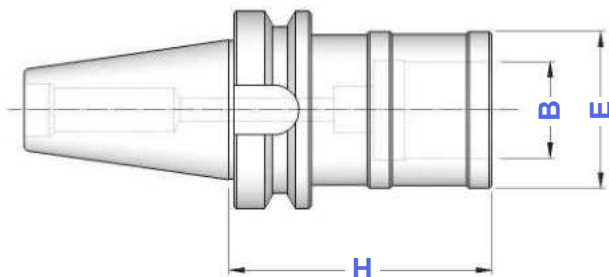

BT





RIDUZIONI E ADATTATORI

REDUCTIONS AND ADAPTERS



BT ⇔ ISO/TC/BT

BT ⇔ NT/SK/BT

TIPO	FORMA A		H	E	DIN 2080	BT DIN 69871				
	Art.	A								
BT 40 - ISO 30/TC 30/BT 30	4180		70	50	* 7410	* 0177			* 7423	4570
BT 40 - ISO 40/TC 40/BT 40	8707		100	68	* 7411	* 0179			* 7424	4571
BT 50 - ISO 40/TC 40/BT 40	4273		70	78	* 7411	* 0179			* 7424	4571
BT 50 - ISO 50/TC 50/BT 50	8708		120	100	* 7417	* 0254			* 7426	4780

* Compresi nella fornitura
Included in the supply

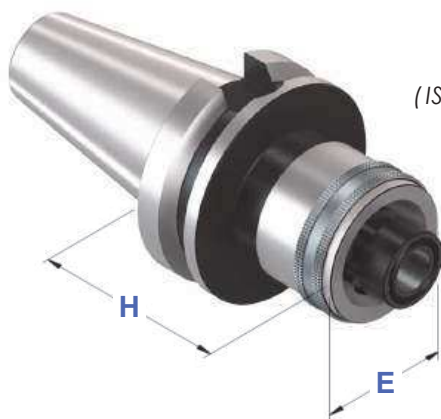

BT ⇔ HSK A+C

BT ⇔ DIN 69893-1

(ISO 7388-2 ⇔ ISO 12164-1)

TIPO	FORMA AD+B		
	Art.	H	E
BT 40 - HSK 63 A+C	6098	80	63
BT 50 - HSK 63 A+C	6099	70	63



BT ⇔ POLIGONALE

BT ⇔ ISO 26623-1

(ISO 7388-2 ⇔ ISO 26623-1)

TIPO	FORMA AD+B		H	E
	Art.	DOPPIO CONTATTO		
BT 40 - C 40/H 30	11026	—	30	40
BT 40 - C 40/H 40	—	11039	40	40
BT 40 - C 50/H 50	11028	11040	50	50
BT 40 - C 50/H 90	11029	—	90	50
BT 40 - C 63/H 75	11030	11041	75	63
BT 50 - C 40/H 40	11031	11042	40	40
BT 50 - C 40/H 70	11032	11043	70	40
BT 50 - C 50/H 40	11033	11044	40	50
BT 50 - C 50/H 80	11034	11045	80	50
BT 50 - C 63/H 50	11035	11046	50	63
BT 50 - C 63/H 90	11036	—	90	63
BT 50 - C 63/H 100	—	11047	100	63
BT 50 - C 80/H 70	11037	11048	70	80
BT 50 - C 80/H 120	11038	11049	120	80

CARATTERISTICHE TECNICHE HSK A+C (DIN 69893-1 / ISO 12164-1)

HSK A+C (DIN 69893-1 / ISO 12164-1) STANDARD FEATURES

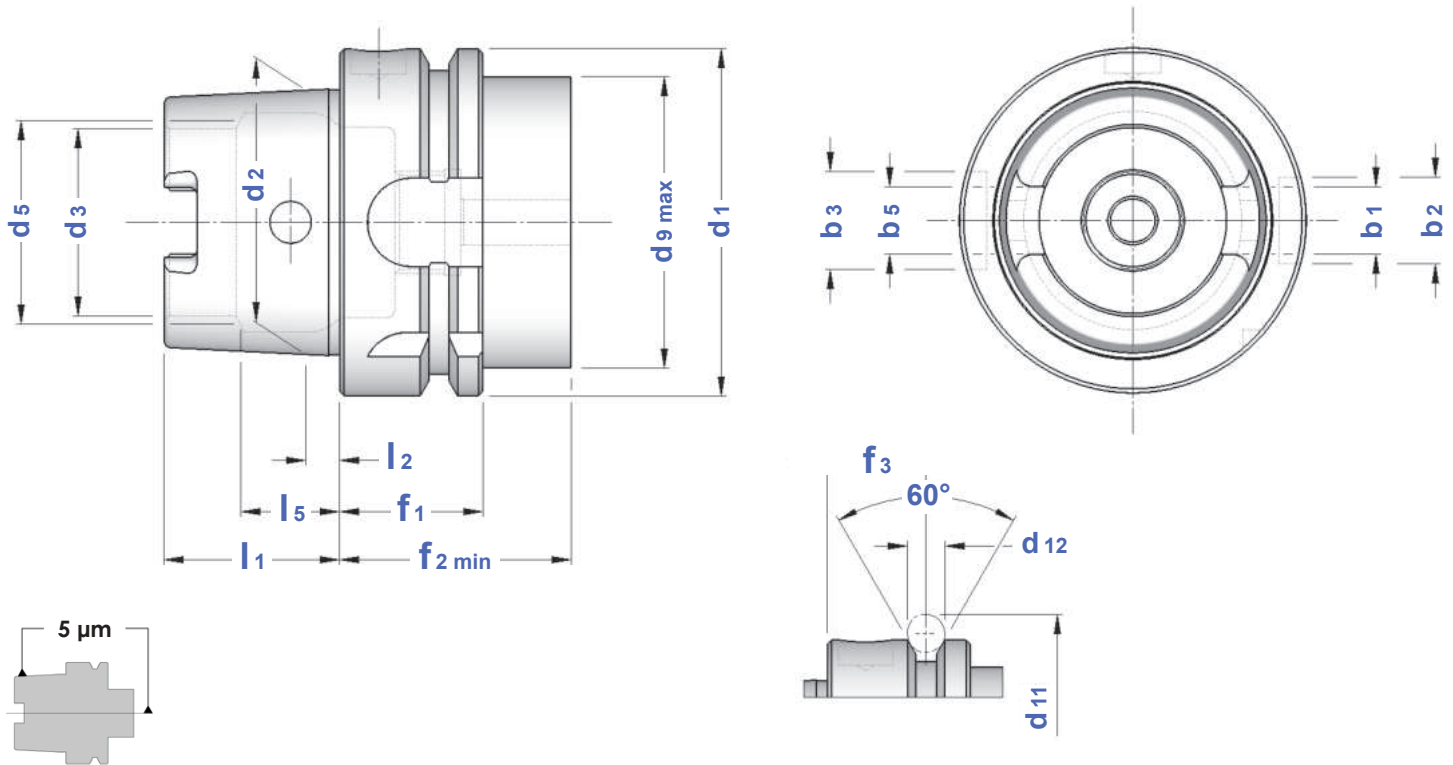

CONO	b1	b2	b3	b5	d1	d2	d3	d5	d9	d11	d12	f1	f2	f3	l1	l2	l5
HSK 25 A+C	6,05	6	7	6,05	25	19	14	15	20	28,5	3	10	20	4,5	13	2,5	7,21
HSK 32 A+C	7,05	7	9	7,05	32	24	17	19	26	37	4	20	35	16	16	3,2	8,92
HSK 40 A+C	8,05	9	11	8,05	40	30	21	23	34	45	4	20	35	16	20	4	11,42
HSK 50 A+C	10,54	12	14	10,54	50	38	26	29	42	59,3	7	26	42	18	25	5	14,13
HSK 63 A+C	12,54	16	18	12,54	63	48	34	37	53	72,3	7	26	42	18	32	6,3	18,13
HSK 63 T	12,54	16	18	12,42	63	48	34	37	62	72,3	7	26	30	18	32	6,3	18,13
HSK 80 A+C	16,04	18	20	16,04	80	60	42	46	68	88,8	7	26	42	18	40	8	22,85
HSK 100 A+C	20,02	20	22	20,02	100	75	53	58	88	109,75	7	29	45	20	50	10	28,56

HSK 63 T ⇨ ISO 12164-3

ADDUTTORI PER REFRIGERANTE
COOLANT TUBES

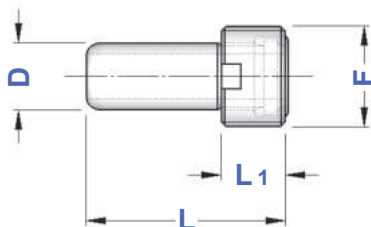

Art.	HSK	F	D	L	L1	OR O-RING	CHIAVE WRENCH
0413	HSK 32 A+C	M 10 x 1	6	26,0	5,5	5668	0470
0414	HSK 40 A+C	M 12 x 1	8	29,3	7,5	5672	0471
0415	HSK 50 A+C	M 16 x 1	10	33,0	9,5	5673	0472
0416	HSK 63 A+C	M 18 x 1	12	36,6	11,5	5674	0473
0418	HSK 100 A+C	M 24 x 1,5	16	44,0	15,5	5675	0474

Gli adduttori sono forniti completi di OR
Coolant tubes are supplied complete with O-Ring

INDICE DELL' ATTACCO HSK A+C (DIN 69893-1 / ISO 12164-1)

INDEX OF HSK A+C SHANK (DIN 69893-1 / ISO 12164 -1)

**PORTAPINZA ER
ghiera MINI**

ER MINI NUT
COLLET CHUCKS
pag. 158



**PORTAPINZA ER
ghiera ESAGONALE**

ER HEXAGONAL NUT
COLLET CHUCKS
pag. 158



**PORTAPINZA ER
ghiera STANDARD**

ER STANDARD NUT
COLLET CHUCKS
pag. 159



AUTOSERRANTI INTEGRALI

MONOLITHIC DRILL CHUCKS

pag. 160



**attacchi per
AUTOSERRANTI**

SHANKS for
DIN 238 DRILL CHUCKS
pag. 160



FORTE SERRAGGIO

HIGH GRIP CHUCKS

pag. 161



SERRAGGIO IDRAULICO

HYDRAULIC CHUCKS

pag. 162



**mandrini per
PINZE EOC**

DIN 6388 EOC
COLLET CHUCKS
pag. 163



PORTA PUNTE ad INSERTI

INDEXABLE DRILL HOLDERS

pag. 163



PORTAFRESE WELDON

END MILL HOLDERS
for DIN 1835-B SHANK

pag. 164 - 165



**WELDON con CANALI
di REFRIGERAZIONE**

END MILL HOLDERS
with COOLANT CHANNELS
pag. 166



**PORTAFRESE
WHISTLE NOTCH**

END MILL HOLDERS
for DIN 1835-E SHANK
pag. 167



BARRE a STELO TENERO

BLANK BARS

pag. 168



BARRE di CONTROLLO

TEST ARBORS

pag. 168



**riduzioni a CONO MORSE
per PUNTE**

MT ADAPTERS for Twist Drills

pag. 169



**riduzioni a CONO MORSE
per FRESE**

MT ADAPTERS for Milling Cutters

pag. 169



➔ segue
continue

PORTAFRESE FISSI

FACE MILL HOLDERS

pag. 170

**TAPPI di PROTEZIONE**

(HSK A+C)

BLANKING PLUGS

pag. 171

**MASCHIATORI**

TAPPING CHUCKS

pag. 173

**adattatori da HSK A+C
a POLIGONALE**HSK A+C to POLYGONAL
ADAPTERS

pag. 174

**PORTAFRESE COMBINATI**

COMBI SHELL MILL HOLDERS

pag. 171

**PORTA FRESE con
ATTACCO FILETTATO**

THREADED SHANK

MILLING CUTTERS HOLDERS

pag. 172

**riduzioni e prolunghhe
da HSK A+C a HSK A+C**

HSK A+C to HSK A+C

ADAPTERS and EXTENSIONS

pag. 174

**indice HSK T**

HSK T index

pag. 175

**ADDUTTORI per
REFRIGERANTE e CHIAVI**COOLANT TUBES
and WRENCHES

pag. 155

**TAMPONI PULITORI
per SEDE HSK**

CLEANERS for HSK SEAT

pag. 243

**SMONTACONI
ORIENTABILI**ORIENTABLE
TIGHTENING FIXTURES

pag. 241

**MAGAZZINI PORTACONI**

TOOL STORES

pag. 244 - 245



HSK A+C

PORTAPINZA ER - GHIERA MINI

ER COLLET CHUCKS with MINI NUT



Balanced G 6,3
20.000 rpm

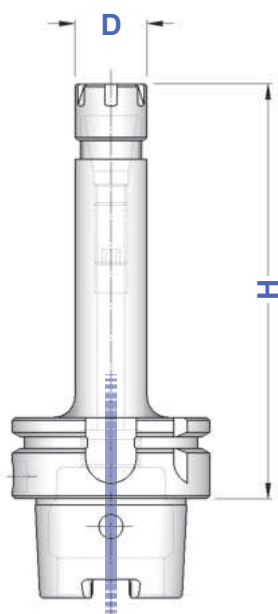
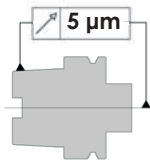

TIPO	Art.	D	RANGE			
HSK 32 A - ER 16 GM/H 65	6000	22	ER16 1÷12	1229	5719	0364
HSK 32 A - ER 25 GM/H 70	6004	35	ER25 1÷20	1231	5721	0996
HSK 40 A - ER 16 GM/H 60	6006	22	ER16 1÷12	1229	5719	0364
HSK 40 A - ER 16 GM/H 120	6007					
HSK 50 A - ER 16 GM/H 100	6002	22	ER16 1÷12	1229	5719	0364
HSK 50 A - ER 16 GM/H 160	6013					
HSK 63 A - ER 11 GM/H 70	6003	16	ER11 1÷8	0432	5718	5573
HSK 63 A - ER 11 GM/H 100	6073					
HSK 63 A - ER 11 GM/H 130	6005					
HSK 63 A - ER 11 GM/H 160	6074					
HSK 63 A - ER 16 GM/H 70	6008	22	ER16 1÷12	1229	5719	0364
HSK 63 A - ER 16 GM/H 100	6018					
HSK 63 A - ER 16 GM/H 130	6009					
HSK 63 A - ER 16 GM/H 160	6019					
HSK 63 A - ER 16 GM/H 200	6109					
HSK 63 A - ER 20 GM/H 70	6119	28	ER20 1÷15	1230	5720	0787
HSK 63 A - ER 20 GM/H 100	6020					
HSK 63 A - ER 20 GM/H 130	6301					
HSK 63 A - ER 20 GM/H 160	6021					
HSK 63 A - ER 20 GM/H 200	6303					
HSK 63 A - ER 25 GM/H 70	6121	35	ER25 1÷20	1231	5721	0996
HSK 63 A - ER 25 GM/H 100	6022					
HSK 63 A - ER 25 GM/H 130	6123					
HSK 63 A - ER 25 GM/H 160	6023					
HSK 63 A - ER 25 GM/H 200	6129					
HSK100 A - ER 16 GM/H 100	6024	22	ER16 1÷12	1229	5719	0364
HSK100 A - ER 16 GM/H 160	6025					
HSK100 A - ER 16 GM/H 200	6305					
HSK100 A - ER 20 GM/H 100	6307	28	ER20 1÷15	1230	5720	0787
HSK100 A - ER 20 GM/H 160	6308					
HSK100 A - ER 20 GM/H 200	6310					
HSK100 A - ER 25 GM/H 100	6311	35	ER25 1÷20	1231	5721	0996
HSK100 A - ER 25 GM/H 160	6026					
HSK100 A - ER 25 GM/H 200	6313					

HSK A+C

PORTAPINZA ER - GHIERA ESAGONALE

ER COLLET CHUCKS with HEXAGONAL NUT



Balanced G 6,3
20.000 rpm

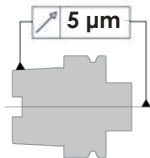

TIPO	Art.	D	RANGE			
HSK 63 A - ER 16 GE /H 70	6200	28	ER16 1÷12	1214	2906	0364
HSK 63 A - ER 16 GE /H 100	6201					
HSK 63 A - ER 16 GE /H 130	6202					
HSK 63 A - ER 16 GE /H 160	6203					
HSK 63 A - ER 16 GE /H 200	6204					
HSK 63 A - ER 20 GE /H 70	6205	34	ER20 1÷15	1215	2907	0787
HSK 63 A - ER 20 GE /H 100	6206					
HSK 63 A - ER 20 GE /H 130	6207					
HSK 63 A - ER 20 GE /H 160	6208					
HSK 63 A - ER 20 GE /H 200	6209					
HSK 100 A - ER 16 GE /H 100	6210	28	ER16 1÷12	1214	2906	0364
HSK 100 A - ER 16 GE /H 160	6211					
HSK 100 A - ER 16 GE /H 200	6212					
HSK 100 A - ER 20 GE /H 100	6213	34	ER20 1÷15	1215	2907	0787
HSK 100 A - ER 20 GE /H 160	6214					
HSK 100 A - ER 20 GE /H 200	6215					

HSK A + C

PORTAPINZA ER - GHIERA STANDARD

ER COLLET CHUCKS with STANDARD NUT

Balanced G 6,3
20.000 rpm

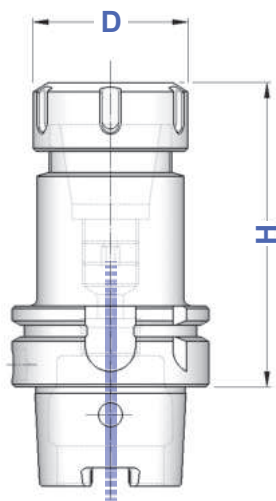
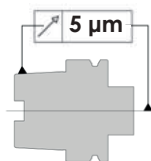

TIPO	Art.	D	RANGE			
HSK 40 A - ER 25/H 65	6030	42	ER25 1÷20	4995	3669	0996
HSK 40 A - ER 25/H 80	6031					
HSK 40 A - ER 32/H 65	6032	50	ER32 2÷25	4996	3670	0988
HSK 40 A - ER 32/H 100	6033					
HSK 50 A - ER 25/H 70	6038	42	ER25 1÷20	4995	3669	0996
HSK 50 A - ER 25/H 100	6039					
HSK 50 A - ER 32/H 70	6040	50	ER32 2÷25	4996	3670	0988
HSK 50 A - ER 32/H 100	6041					
HSK 50 A - ER 32/H 160	6043					
HSK 50 A - ER 40/H 75	6247	63	ER40 3÷32	4997	3671	0821
HSK 50 A - ER 40/H 100	6248					
HSK 63 A - ER 16/H 70	6044	32	ER16 1÷12	4993	3698	0364
HSK 63 A - ER 16/H 100	6045					
HSK 63 A - ER 16/H 130	6046					
HSK 63 A - ER 16/H 160	6047					
HSK 63 A - ER 16/H 200	6747					
HSK 63 A - ER 20/H 70	6048	35	ER20 1÷15	4994	3699	0787
HSK 63 A - ER 20/H 100	6049					
HSK 63 A - ER 20/H 130	6050					
HSK 63 A - ER 20/H 160	6051					
HSK 63 A - ER 20/H 200	6751					
HSK 63 A - ER 25/H 70	6052	42	ER25 1÷20	4995	3669	0996
HSK 63 A - ER 25/H 100	6053					
HSK 63 A - ER 25/H 130	6054					
HSK 63 A - ER 25/H 160	6055					
HSK 63 A - ER 25/H 200	6755					
HSK 63 A - ER 32/H 75	6056	50	ER32 2÷25	4996	3670	0988
HSK 63 A - ER 32/H 100	6057					
HSK 63 A - ER 32/H 130	6058					
HSK 63 A - ER 32/H 160	6059					
HSK 63 A - ER 32/H 200	6785					
HSK 63 A - ER 40/H 80	6060	63	ER40 3÷32	4997	3671	0821
HSK 63 A - ER 40/H 100	6106					
HSK 63 A - ER 40/H 120	6061					
HSK 63 A - ER 40/H 160	6062					
HSK 63 A - ER 40/H 200	6790					
HSK 63 A - ER 50/H 105	6064	78	ER50 6÷36	4998	3668	4055
HSK 100 A - ER 16/H 100	6464	32	ER16 1÷12	4993	3698	0364
HSK 100 A - ER 16/H 160	6465					
HSK 100 A - ER 16/H 200	6466					
HSK 100 A - ER 20/H 100	6467	35	ER20 1÷15	4994	3699	0787
HSK 100 A - ER 20/H 160	6468					
HSK 100 A - ER 20/H 200	6469					
HSK 100 A - ER 25/H 100	6063	42	ER25 1÷20	4995	3669	0996
HSK 100 A - ER 25/H 160	6065					
HSK 100 A - ER 25/H 200	6066					
HSK 100 A - ER 32/H 100	6067	50	ER32 2÷25	4996	3670	0988
HSK 100 A - ER 32/H 120	6107					
HSK 100 A - ER 32/H 160	6069					
HSK 100 A - ER 32/H 200	6070					
HSK 100 A - ER 40/H 100	6108	63	ER40 3÷32	4997	3671	0821
HSK 100 A - ER 40/H 120	6071					
HSK 100 A - ER 40/H 160	6072					
HSK 100 A - ER 40/H 200	6076					
HSK 100 A - ER 50/H 120	6068	78	ER50 6÷36	4998	3668	4055



Adduttori per refrigerante
Coolant tubes
p.155



HSK A + C

MANDRINI AUTOSERRANTI INTEGRALI ROTAZIONE DESTRA E SINISTRA

MONOLITHIC DRILL CHUCKS - RIGHT & LEFT SPIN



TIPO	Art.	RANGE	E	H	
HSK 50 A - DCU 13	8830	0,5 ÷ 13	50	100	2372
HSK 63 A - DCU 13	8831	0,5 ÷ 13	50	105	2372
HSK 63 A - DCU 16	8832	3 ÷ 16	57	110	
HSK 100 A - DCU 13	8833	0,5 ÷ 13	50	108	2372
HSK 100 A - DCU 16	8834	3 ÷ 16	57	111	

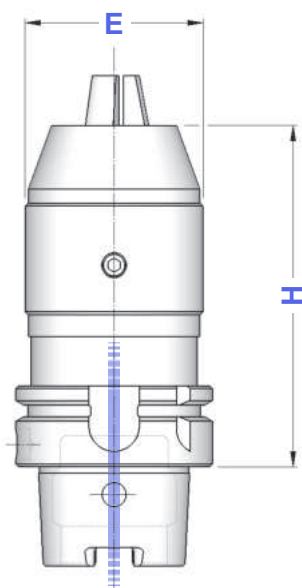

Forniti completi dell'apposita chiave
Supplied complete with suitable wrench

HSK A + C

ATTACCHI PER MANDRINI AUTOSERRANTI

SHANKS FOR DRILL CHUCKS DIN 238 / ISO 239 TYPE

TIPO	Art.	D	H
HSK 63 A - B12	6014	12,065	45
HSK 63 A - B16	6015	15,733	45
HSK 63 A - B18	6016	17,780	45

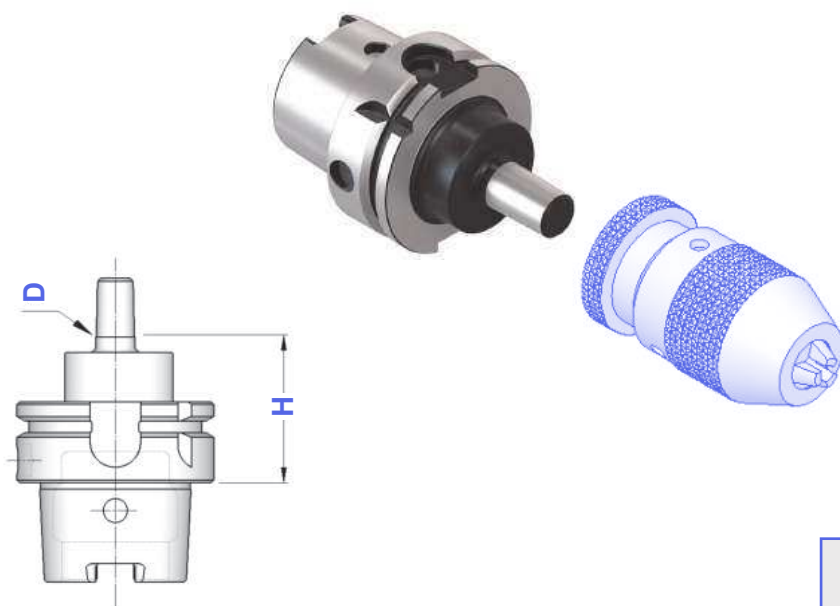

I Mandrini Autoserranti
si trovano a pagina 62

Keyless Drill Chucks
you can find at page 62

HSK A + C

MANDRINI A FORTE SERRAGGIO HIGH GRIP CHUCKS

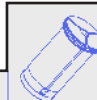

Balanced G 6,3
12.000 rpm



Forniti completi dell'apposita chiave
Supplied complete with suitable wrench

TIPO	Art.	E	D	
HSK 63 A - PC 12 / H 85	6706	34	12	0804
HSK 63 A - PC 16 / H 85	6707	42	16	0805
HSK 63 A - PC 20 / H 85	6708	50	20	0809
HSK 63 A - PC 20 / H 105	6243	54	20	0809
HSK 63 A - PC 32 / H 110	6709	63	32	0810
HSK 63 A - PC 32 / H 130	6244	72	32	0810
HSK 100 A - PC 20 / H 110	6245	54	20	0809
HSK 100 A - PC 20 / H 140	6710	50	20	0809
HSK 100 A - PC 32 / H 125	6246	72	32	0810
HSK 100 A - PC 32 / H 160	6711	63	32	0810

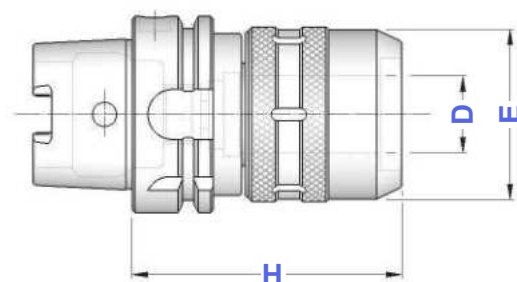

Pinze precisione standard pag. 270
Pinze alta precisione pag. 271

Standard precision collets page 270
High precision collets page 271



SERIE RIDOTTA DI PINZE PC in CONFEZIONI SINGOLE REDUCED SET OF PC COLLETS IN SINGLE PACKS



TIPO	Diametri	n° pinze	Art.
PC 20 - Ridotta	Ø 6 - 8 - 10 - 12 - 16	5	7680
PC 25 - Ridotta	Ø 6 - 8 - 10 - 12 - 16 - 20	6	7681
PC 32 - Ridotta	Ø 6 - 8 - 10 - 12 - 16 - 20 - 25	7	7682



SERIE RIDOTTA DI PINZE PC in VALIGETTA REDUCED SET OF PC COLLETS IN CASE



TIPO	Diametri	n° pinze	Art.
PC 20 - Ridotta	Ø 6 - 8 - 10 - 12 - 16	5	7683
PC 25 - Ridotta	Ø 6 - 8 - 10 - 12 - 16 - 20	6	7684
PC 32 - Ridotta	Ø 6 - 8 - 10 - 12 - 16 - 20 - 25	7	7685

HSK A + C

MANDRINI A SERRAGGIO IDRAULICO

HYDRAULIC CHUCKS

Balanced G 2,5
25.000 rpm



TIPO	Art.	D	H	E	E1	L
HSK 63 A - HYDRO 6	6412	6	70	28	50	24
HSK 63 A - HYDRO 8	6413	8	70	30	50	24
HSK 63 A - HYDRO 10	6414	10	80	32	50	35
HSK 63 A - HYDRO 12	6415	12	85	34	50	40
HSK 63 A - HYDRO 16	6417	16	90	38	50	46
HSK 63 A - HYDRO 20	6419	20	90	43	50	48
HSK 63 A - HYDRO 25	6420	25	120	57	63	59
HSK 63 A - HYDRO 32	6421	32	125	63	75	63
HSK 100 A - HYDRO 6	6422	6	75	28	54	26
HSK 100 A - HYDRO 8	6423	8	75	30	54	26
HSK 100 A - HYDRO 10	6424	10	90	32	50	42
HSK 100 A - HYDRO 12	6425	12	95	34	50	47
HSK 100 A - HYDRO 16	6427	16	100	38	50	53
HSK 100 A - HYDRO 20	6429	20	105	43	50	59
HSK 100 A - HYDRO 25	6430	25	110	57	63	62
HSK 100 A - HYDRO 32	6431	32	110	63	75	62

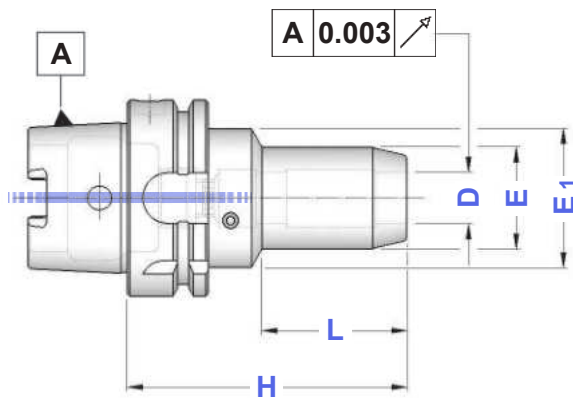

Applicazioni: bloccaggio ad alta precisione di utensili a gambo cilindrico in tolleranza h6
Attenzione : non azionare il sistema idraulico se l'utensile non è inserito completamente nel mandrino
Applications : high precision locking of cylindrical shank tools with shank tolerance h6
Warning : do not start Hydraulic System if tool is not completely fitted into the spindle

PINZE CILINDRICHE A TENUTA STAGNA

WATERTIGHT CYLINDRICAL COLLETS

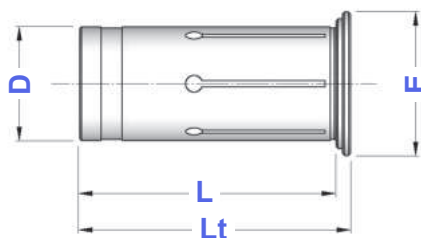

p.272



TIPO	Art.	D	E	L	Lt	RANGE	Diametri
PH 12	0520	12	16,5	45	47	3 ÷ 8 OVERSIZE 9 ÷ 10	∅ 3-4-5-6-7-8-9-10
PH 20	0521	20	24	50,5	52,5	3 ÷ 16 OVERSIZE 17 ÷ 18	∅ 3-4-5-6-7-8-9-10-11-12-13-14-15-16-17-18
PH 25	0676	25	29	54,5	56,5	3 ÷ 20 OVERSIZE 21 ÷ 22	∅ 3-4-5-6-7-8-9-10-11-12-13-14-15-16-17-18 19-20-21-22
PH 32	0522	32	35,5	60,5	62,5	4 ÷ 25 OVERSIZE 26 ÷ 28	∅ 4-5-6-7-8-9-10-11-12-13-14-15-16-17-18 19-20-21-22-23-24-25-26-27-28

HSK A + C

MANDRINI PER PINZE EOC DIN 6388 DIN 6388 COLLET CHUCKS

Balanced G 6,3
15.000 rpm



TIPO	Art.	D	RANGE			
HSK 50 A - EOC 16 / H 100	6090	43	EOC16 2÷16	4067	2883	0768
HSK 50 A - EOC 25 / H 100	6091	60	EOC25 2÷25	4068	2909	0769
HSK 63 A - EOC 16 / H 100	6092	43	EOC16 2÷16	4067	2883	0768
HSK 63 A - EOC 25 / H 100	6093	60	EOC25 2÷25	4068	2909	0769
HSK 63 A - EOC 32 / H 120	6094	72	EOC32 3÷32	4069	2910	0770
HSK 100 A - EOC 16 / H 110	6095	43	EOC16 2÷16	4067	2883	0768
HSK 100 A - EOC 25 / H 120	6096	60	EOC25 2÷25	4068	2909	0769
HSK 100 A - EOC 32 / H 130	6097	72	EOC32 3÷32	4069	2910	0770

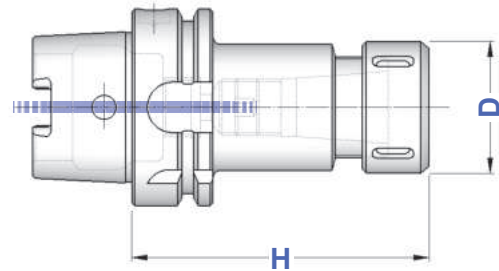

Pinze, ghiera e chiavi
EOC - DIN 6388
si trovano da pagina 268

Collets, nuts and wrenches
EOC - DIN 6388 type
you can find from page 268



HSK A + C

MANDRINI PER PUNTE AD INSERTI INDEXABLE DRILL HOLDERS

Balanced G 6,3
12.000 rpm



TIPO	Art.	D	H	E	L	
HSK 63 A - D. 16 P	6403	16	80	36	54	0403
HSK 63 A - D. 20 P	6404	20	80	40	54	0403
HSK 63 A - D. 25 P	6405	25	90	45	59	0417
HSK 63 A - D. 32 P	6406	32	90	52	63	0417

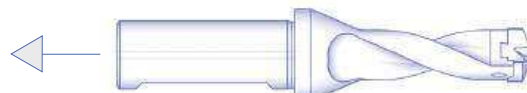
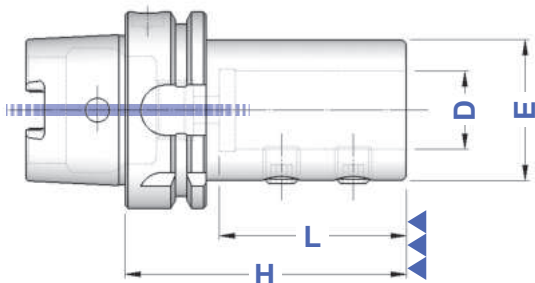

HSK A + C

PORTAFRESE WELDON END MILL HOLDERS FOR DIN 1835-B SHANKS

Balanced G 6,3
15.000 rpm



WE6 ÷ WE20
1 grano
1 screw



WE25 ÷ WE50
2 grani
2 screws

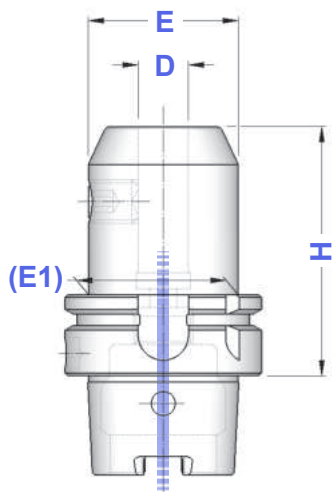

TIPO	Art.	D	H	E	
HSK 40 A - WE 6/H 60	6110	6	60	25	4970
HSK 40 A - WE 8/H 60	6112	8	60	28	4971
HSK 40 A - WE10/H 65	6114	10	65	35	4972
HSK 40 A - WE12/H 70	6116	12	70	42	4973
HSK 40 A - WE16/H 80	6120	16	80	48	4974
HSK 40 A - WE20/H 80	6124	20	80	52	4975
HSK 50 A - WE 6/H 65	6130	6	65	25	4970
HSK 50 A - WE 8/H 65	6132	8	65	28	4971
HSK 50 A - WE10/H 65	6134	10	65	35	4972
HSK 50 A - WE12/H 80	6136	12	80	42	4973
HSK 50 A - WE14/H 80	6138	14	80	44	4973
HSK 50 A - WE16/H 80	6140	16	80	48	4974
HSK 50 A - WE18/H 80	6142	18	80	50	4974
HSK 50 A - WE20/H 80	6144	20	80	52	4975
HSK 50 A - WE25/H 105	6146	25	105	65	4976
HSK 50 A - WE32/H 120	6147	32	120	72	4977
HSK 63 A - WE 6/H 65	6150	6	65	18	0020
HSK 63 A - WE 6/H 100	6966		100		
HSK 63 A - WE 6/H 130	6993		130		
HSK 63 A - WE 6/H 160	6151		160		
HSK 63 A - WE 8/H 65	6152	8	65	22	0021
HSK 63 A - WE 8/H 100	6967		100		
HSK 63 A - WE 8/H 130	6994		130		
HSK 63 A - WE 8/H 160	6153		160		
HSK 63 A - WE10/H 65	6154	10	65	30	0060
HSK 63 A - WE10/H 100	6968		100		
HSK 63 A - WE10/H 130	6995		130		
HSK 63 A - WE10/H 160	6155		160		
HSK 63 A - WE12/H 80	6156	12	80	34	0260
HSK 63 A - WE12/H 100	6969		100		
HSK 63 A - WE12/H 130	6996		130		
HSK 63 A - WE12/H 160	6157		160		
HSK 63 A - WE14/H 80	6158	14	80	44	4973
HSK 63 A - WE14/H 100	6159		100		
HSK 63 A - WE14/H 160	6970		160		
HSK 63 A - WE16/H 80	6160	16	80	42	0261
HSK 63 A - WE16/H 100	6971		100		
HSK 63 A - WE16/H 130	6997		130		
HSK 63 A - WE16/H 160	6161		160		
HSK 63 A - WE18/H 80	6162	18	80	44	0261
HSK 63 A - WE18/H 100	6163		100		
HSK 63 A - WE18/H 160	6972		160		
HSK 63 A - WE20/H 80	6164	20	80	52	4975
HSK 63 A - WE20/H 100	6973		100		
HSK 63 A - WE20/H 130	6998		130		
HSK 63 A - WE20/H 160	6165		160		
HSK 63 A - WE25/H 110	6166	25	110	65	4976
HSK 63 A - WE25/H 130	6999		130		
HSK 63 A - WE25/H 160	6167		160		
HSK 63 A - WE32/H 110	6168	32	110	72	4977
HSK 63 A - WE32/H 160	6169		160		
HSK 63 A - WE40/H 120	6974	40	120	80	4977

segue
continue



➔ segue
continue

Balanced G 6,3
15.000 rpm



WE6 ÷ WE20
1 grano
1 screw



WE25 ÷ WE50
2 grani
2 screws

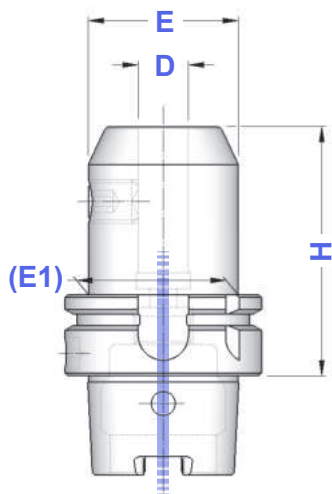

TIPO	Art.	D	H	E	
HSK 100 A - WE 6/H 80	6170	6	80	25	4970
HSK 100 A - WE 6/H 160	6171		160		
HSK 100 A - WE 6/H 200	6712		200		
HSK 100 A - WE 8/H 80	6172	8	80	28	4971
HSK 100 A - WE 8/H 160	6173		160		
HSK 100 A - WE 8/H 200	6713		200		
HSK 100 A - WE10/H 80	6174	10	80	35	4972
HSK 100 A - WE10/H 160	6175		160		
HSK 100 A - WE10/H 200	6714		200		
HSK 100 A - WE12/H 80	6176	12	80	42	4973
HSK 100 A - WE12/H 160	6177		160		
HSK 100 A - WE12/H 200	6715		200		
HSK 100 A - WE14/H 80	6178	14	80	44	4973
HSK 100 A - WE14/H 160	6179		160		
HSK 100 A - WE14/H 200	6716		200		
HSK 100 A - WE16/H 100	6180	16	100	48	4974
HSK 100 A - WE16/H 160	6181		160		
HSK 100 A - WE16/H 200	6717		200		
HSK 100 A - WE18/H 100	6182	18	100	50	4974
HSK 100 A - WE18/H 160	6183		160		
HSK 100 A - WE18/H 200	6718		200		
HSK 100 A - WE20/H 100	6184	20	100	52	4975
HSK 100 A - WE20/H 160	6185		160		
HSK 100 A - WE20/H 200	6719		200		
HSK 100 A - WE25/H 100	6186	25	100	65	4976
HSK 100 A - WE25/H 160	6187		160		
HSK 100 A - WE25/H 200	6720		200		
HSK 100 A - WE32/H 100	6188	32	100	72	4977
HSK 100 A - WE32/H 160	6189		160		
HSK 100 A - WE32/H 200	6721		200		
HSK 100 A - WE40/H 120	6190	40	120	80	4977
HSK 100 A - WE40/H 160	6192		160		
HSK 100 A - WE40/H 200	6722		200		
HSK 100 A - WE50/H 130	6191	50	130	100	4978
HSK 100 A - WE50/H 160	6723		160		

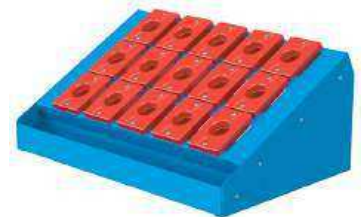

Magazzini Portaconi p.244
Tools Stores p.244



Smontaconi Orientabili HSK p.241
Orientable HSK Tightening Fixtures p.241



p.259



Adduttori per refrigerante

Coolant tubes

p.155

HSK A + C

PORTAFRESE WELDON CON CANALI DI REFRIGERAZIONE

END MILL HOLDERS with COOLANT CHANNELS for DIN 1835-B SHANKS



Balanced G 6,3
15.000 rpm



WEC 6 ÷ WEC 20
1 grano
1 screw



WEC 25 ÷ WEC 40
2 grani
2 screws

TIPO	Art.	D	H	E	
HSK 63A - WEC 6 / H 65	6912	6	65	25	4970
HSK 63A - WEC 8 / H 65	6913	8	65	28	4971
HSK 63A - WEC 10 / H 65	6914	10	65	35	4972
HSK 63A - WEC 12 / H 80	6915	12	80	42	4973
HSK 63A - WEC 14 / H 80	6916	14	80	44	4973
HSK 63A - WEC 16 / H 80	6917	16	80	48	4974
HSK 63A - WEC 18 / H 80	6918	18	80	50	4974
HSK 63A - WEC 20 / H 80	6919	20	80	52	4975
HSK 63A - WEC 25 / H 110	6920	25	110	65	4976
HSK 63A - WEC 32 / H 110	6921	32	110	72	4977
HSK 63A - WEC 40 / H 125	6922	40	125	80	4977
HSK 100A - WEC 6 / H 80	6923	6	80	25	4970
HSK 100A - WEC 8 / H 80	6924	8	80	28	4971
HSK 100A - WEC 10 / H 80	6925	10	80	35	4972
HSK 100A - WEC 12 / H 80	6926	12	80	42	4973
HSK 100A - WEC 14 / H 80	6927	14	80	44	4973
HSK 100A - WEC 16 / H 100	6928	16	100	48	4974
HSK 100A - WEC 18 / H 100	6929	18	100	50	4974
HSK 100A - WEC 20 / H 100	6930	20	100	52	4975
HSK 100A - WEC 25 / H 100	6931	25	100	65	4976
HSK 100A - WEC 32 / H 100	6932	32	100	72	4977
HSK 100A - WEC 40 / H 105	6933	40	105	80	4977

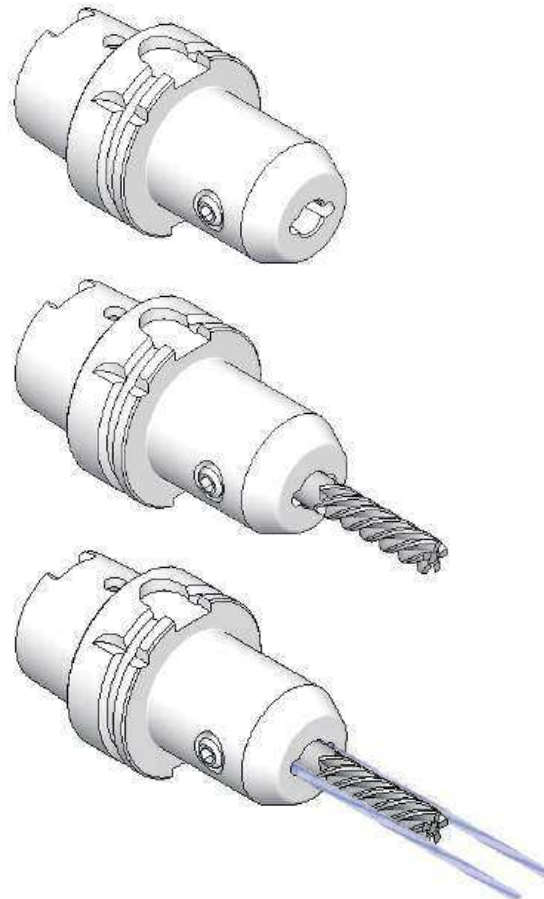
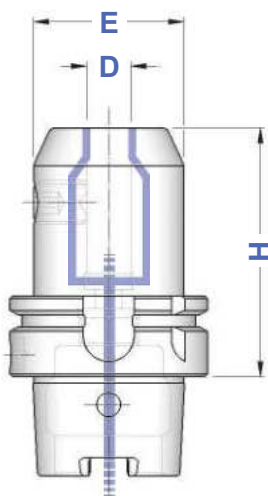

Adduttori per refrigerante



Coolant tubes

p.155

HSK A + C

MANDRINI PER UTENSILI ATTACCO WHISTLE NOTCH END MILL HOLDERS FOR DIN 1835-E SHANKS



Balanced G 6,3
15.000 rpm



WN 6 ÷ WN 20
1 grano
1 screw



WN 25 ÷ WN 40
2 grani
2 screws

TIPO	Art.	D	H	E	
HSK 63 A - WN 6/H 80	6218	6	80	25	4970
HSK 63 A - WN 8/H 80	6219	8	80	28	4971
HSK 63 A - WN 10/H 80	6220	10	80	35	4972
HSK 63 A - WN 12/H 90	6221	12	90	42	4973
HSK 63 A - WN 14/H 90	6222	14	90	44	4973
HSK 63 A - WN 16/H 100	6223	16	100	48	4974
HSK 63 A - WN 18/H 100	6224	18	100	50	4974
HSK 63 A - WN 20/H 100	6225	20	100	52	4975
HSK 63 A - WN 25/H 110	6226	25	110	65	4976
HSK 63 A - WN 32/H 110	6227	32	110	72	4977
HSK 100 A - WN 6/H 90	6228	6	90	25	4970
HSK 100 A - WN 8/H 90	6229	8	90	28	4971
HSK 100 A - WN 10/H 90	6230	10	90	35	4972
HSK 100 A - WN 12/H 100	6231	12	100	42	4973
HSK 100 A - WN 14/H 100	6232	14	100	44	4973
HSK 100 A - WN 16/H 100	6233	16	100	48	4974
HSK 100 A - WN 18/H 100	6234	18	100	50	4974
HSK 100 A - WN 20/H 110	6235	20	110	52	4975
HSK 100 A - WN 25/H 120	6236	25	120	65	4976
HSK 100 A - WN 32/H 120	6237	32	120	72	4977
HSK 100 A - WN 40/H 120	6238	40	120	80	4977

2° → WHISTLE NOTCH

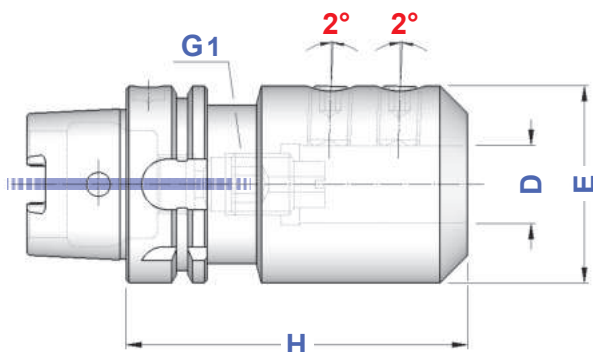
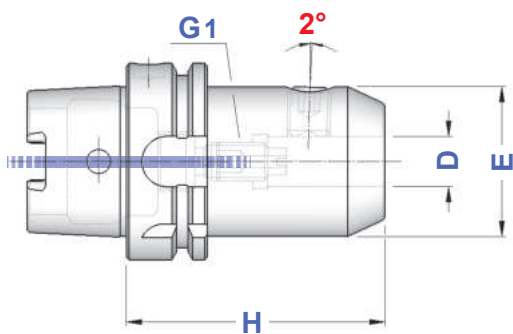
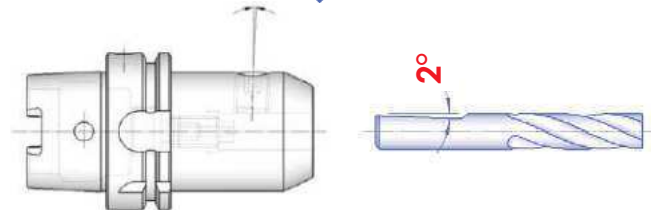

**GRANO di PRESETTAGGIO
con foro passante (G1)**
PPRESETTING SCREW
through hole (G1)

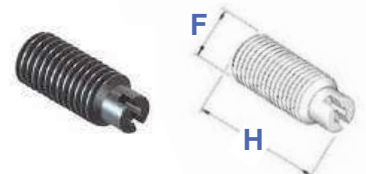

Art.	F x H	Passo
0233	M 5 x 16	0,8
0235	M 6 x 16	1
0238	M 8 x 20	1,25
0240	M 10 x 25	1,5
0245	M 12 x 30	1,75
1226	M 16 x 20	2
0212	M 20 x 20	2,5
0247	M 20 x 30	2,5

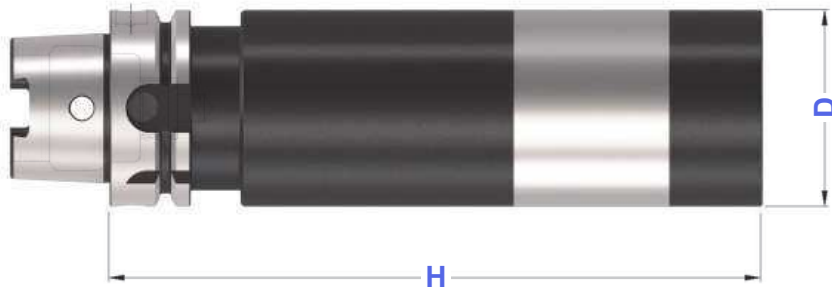
**HSK
A + C****BARRE A STELO TENERO**
BLANK BARS**HSK**

TIPO	Art.	D	H
HSK 32 A - D. 35 ST	6440	35	150
HSK 40 A - D. 40 ST	6441	40	150
HSK 40 A - D. 52 ST	6442	52	200
HSK 50 A - D. 52 ST	6443	52	200
HSK 50 A - D. 63 ST	6444	63	200
HSK 63 A - D. 63 ST	6445	63	250
HSK 63 A - D. 80 ST	6446	80	250
HSK 100 A - D. 63 ST	6447	63	200
HSK 100 A - D. 90 ST	6449	90	300

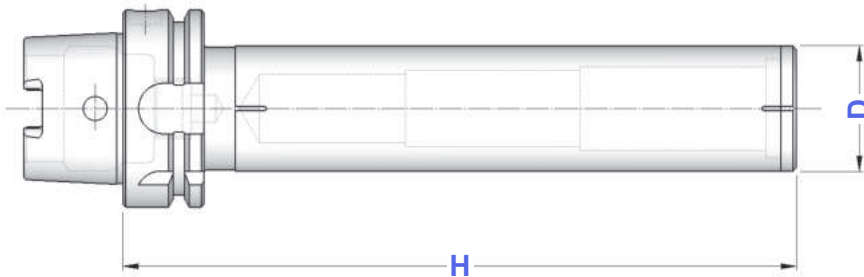
**HSK
A + C****BARRE DI CONTROLLO**
TEST ARBORS

TIPO	Art.	H	D
HSK 63 A - D. 40 SC	6498	380	40
HSK 100 A - D. 40 SC	6499	350	40

Dati costruttivi

- Costruite in acciaio da cementazione certificato
- Cementate con profondità 0,6 - 0,8 mm
- Temprate, rinvenute, brunate
- Durezza HRC 58 ± 2, resistenza 800-1000 N/mm²
- Rotondità in rotazione 0,005
- Cilindricità 0,003

Constructive Features

- Manufactured with hardening steel
- Hardened 0,6 - 0,8 mm depth
- Hardened, tempered, burnished
- Hardness HRC 58 ± 2, strength 800-1000 N/mm²
- Runout accuracy 0,005
- Cylindricity 0,003



Fornite con apposito contenitore
Supplied with suitable case

HSK A + C

RIDUZIONI A CONO MORSE PER PUNTE

MT ADAPTERS FOR TWIST DRILLS

Balanced G 6,3

8.000 rpm



TIPO	Art.	CM	H	E
HSK 50 A - CM 1 PUNTE	6253	1	100	25
HSK 50 A - CM 2 PUNTE	6254	2	120	32
HSK 50 A - CM 3 PUNTE	6255	3	140	40
HSK 63 A - CM 1 PUNTE	6256	1	100	25
HSK 63 A - CM 2 PUNTE	6257	2	115	32
HSK 63 A - CM 3 PUNTE	6258	3	135	40
HSK 63 A - CM 4 PUNTE	6259	4	160	48
HSK 100 A - CM 1 PUNTE	6260	1	110	25
HSK 100 A - CM 2 PUNTE	6261	2	120	32
HSK 100 A - CM 3 PUNTE	6262	3	150	40
HSK 100 A - CM 4 PUNTE	6263	4	170	48
HSK 100 A - CM 5 PUNTE	6264	5	200	63

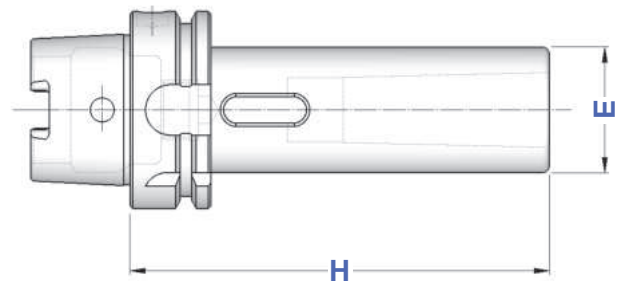

HSK A + C



RIDUZIONI A CONO MORSE PER FRESE

MT ADAPTERS FOR MILLING CUTTERS

Balanced G 6,3

8.000 rpm



TIPO	Art.	CM	H	E		
HSK 50 A - CM 1 FRESE	6278	1	100	25	7420	4568
HSK 50 A - CM 2 FRESE	6279	2	120	32	7422	4569
HSK 50 A - CM 3 FRESE	6280	3	140	40	7423	4570
HSK 63 A - CM 1 FRESE	6281	1	100	25	7420	4568
HSK 63 A - CM 2 FRESE	6282	2	115	32	7422	4569
HSK 63 A - CM 3 FRESE	6283	3	135	40	7423	4570
HSK 63 A - CM 4 FRESE	6284	4	160	48	7424	4571
HSK 100 A - CM 2 FRESE	6286	2	120	32	7422	4569
HSK 100 A - CM 3 FRESE	6287	3	150	40	7423	4570
HSK 100 A - CM 4 FRESE	6288	4	170	48	7424	4571
HSK 100 A - CM 5 FRESE	6289	5	200	63	7425	4572

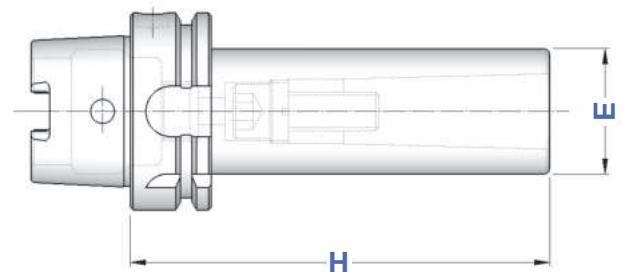

HSK A + C

PORTAFRESE FISSI FACE MILL HOLDERS

Balanced	G 6,3
≤ H160	15.000 rpm
> H160	8.000 rpm



FIGURA 1



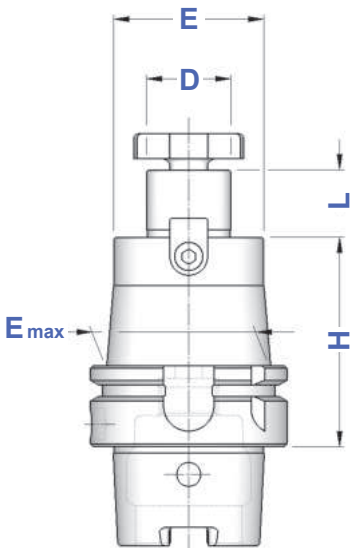

FIGURA 2

con passaggio
REFRIGERANTE
COOLANT THROUGH

TIPO	FIGURA	FIGURA	D	L	E	E _{max}		
	1	2						
HSK 32 A -D.16 FISSO/ H 45	6298	—	16	17	38	—	4985	4562
HSK 32 A -D.22 FISSO/ H 50	6299	—	22	19	48	—	4986	4563
HSK 40 A -D.16 FISSO/ H 45	6300	—	16	17	38	—	4985	4562
HSK 40 A -D.22 FISSO/ H 50	6302	—	22	19	48	—	4986	4563
HSK 50 A -D.16 FISSO/ H 50	6306	—	16	17	38	—	4985	4562
HSK 50 A -D.22 FISSO/ H 60	6309	—	22	19	48	—	4986	4563
HSK 50 A -D.27 FISSO/ H 60	6312	—	27	21	58	—	4987	4564
HSK 50 A -D.32 FISSO/ H 60	6315	—	32	24	66	—	4988	4565
HSK 50 A -D.40 FISSO/ H 70	6316	—	40	27	80	—	4989	4566
HSK 63 A -D.16 FISSO/ H 50	6317	6563	16	17	38	—	4985	4562
HSK 63 A -D.16 FISSO/ H 100	6318	6547						
HSK 63 A -D.16 FISSO/ H 160	6319	6549						
HSK 63 A -D.16 FISSO/ H 200	6519	6811						
HSK 63 A -D.22 FISSO/ H 50	6320	6564	22	19	48	—	4986	4563
HSK 63 A -D.22 FISSO/ H 100	6321	6554						
HSK 63 A -D.22 FISSO/ H 160	6322	6555						
HSK 63 A -D.22 FISSO/ H 200	6522	6812						
HSK 63 A -D.27 FISSO/ H 60	6323	6565	27	21	58	—	4987	4564
HSK 63 A -D.27 FISSO/ H 100	6324	6601						
HSK 63 A -D.27 FISSO/ H 160	6325	6603						
HSK 63 A -D.32 FISSO/ H 60	6326	6566	32	24	66	—	4988	4565
HSK 63 A -D.32 FISSO/ H 100	6327	6605						
HSK 63 A -D.32 FISSO/ H 160	6328	6607						
HSK 63 A -D.40 FISSO/ H 60	6329	6567	40	27	80	—	4989	4566
HSK 63 A -D.40 FISSO/ H 100	6330	6609						
HSK 63 A -D.40 FISSO/ H 160	6331	6611						
HSK 100 A -D.16 FISSO/ H 50	6332	6568						
HSK 100 A -D.16 FISSO/ H 100	6333	6613	16	17	38	—	4985	4562
HSK 100 A -D.16 FISSO/ H 160	6334	6615				43		
HSK 100 A -D.16 FISSO/ H 200	6349	6617				47		
HSK 100 A -D.16 FISSO/ H 250	6351	6618				48		
HSK 100 A -D.22 FISSO/ H 50	6335	6569	22	19	48	—	4986	4563
HSK 100 A -D.22 FISSO/ H 100	6336	6620				53		
HSK 100 A -D.22 FISSO/ H 160	6337	6621				56		
HSK 100 A -D.22 FISSO/ H 200	6353	6623				58		
HSK 100 A -D.22 FISSO/ H 250	6355	6624				58		
HSK 100 A -D.27 FISSO/ H 50	6338	6570	27	21	58	—	4987	4564
HSK 100 A -D.27 FISSO/ H 100	6339	6626				66		
HSK 100 A -D.27 FISSO/ H 160	6340	6627				67		
HSK 100 A -D.27 FISSO/ H 200	6357	6629				68		
HSK 100 A -D.27 FISSO/ H 250	6358	6630				68		
HSK 100 A -D.32 FISSO/ H 50	6341	6571	32	24	66	—	4988	4565
HSK 100 A -D.32 FISSO/ H 100	6342	6632				74		
HSK 100 A -D.32 FISSO/ H 160	6343	6633				75		
HSK 100 A -D.32 FISSO/ H 200	6360	6635				77		
HSK 100 A -D.32 FISSO/ H 250	6361	6636				77		
HSK 100 A -D.40 FISSO/ H 60	6344	6572	40	27	80	—	4989	4566
HSK 100 A -D.40 FISSO/ H 100	6345	6638						
HSK 100 A -D.40 FISSO/ H 160	6346	6639						
HSK 100 A -D.40 FISSO/ H 200	6347	6642						

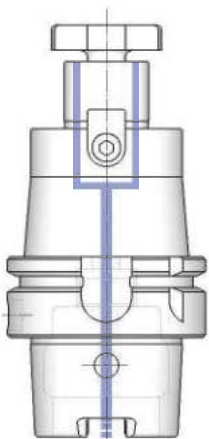

HSK A + C

PORTAFRESE COMBINATI DIN 6358 COMBI SHELL MILL HOLDERS

Balanced G 6,3
8.000 rpm

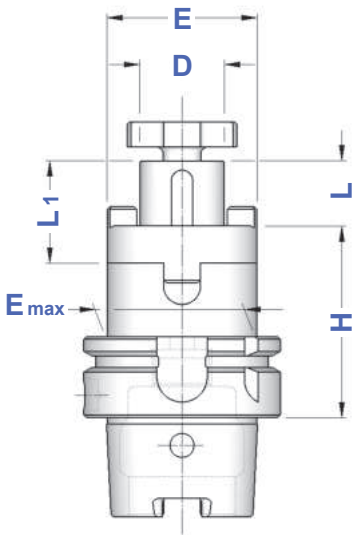

TIPO	Art.	D	L1	L	E	Emax			
HSK 63 A - D.16 C/H 60	6368	16	27	17	32	-	4090	4985	4562
HSK 63 A - D.16 C/H 100	6369								
HSK 63 A - D.16 C/H 160	6370								
HSK 63 A - D.22 C/H 60	6371	22	31	19	40	-	4091	4986	4563
HSK 63 A - D.22 C/H 100	6372								
HSK 63 A - D.22 C/H 160	6373								
HSK 63 A - D.27 C/H 60	6374	27	33	21	48	-	4092	4987	4564
HSK 63 A - D.27 C/H 100	6375								
HSK 63 A - D.27 C/H 160	6376								
HSK 63 A - D.32 C/H 60	6377	32	38	24	58	-	4093	4988	4565
HSK 63 A - D.32 C/H 100	6378								
HSK 63 A - D.32 C/H 160	6379								
HSK 63 A - D.40 C/H 70	6380	40	41	27	70	-	4094	4989	4566
HSK 63 A - D.40 C/H 100	6381								
HSK 63 A - D.40 C/H 160	6382								
HSK 100 A - D.16 C/H 100	6384	16	27	17	32	44	4090	4985	4562
HSK 100 A - D.16 C/H 160	6385								
HSK 100 A - D.22 C/H 100	6387	22	31	19	40	50	4091	4986	4563
HSK 100 A - D.22 C/H 160	6388								
HSK 100 A - D.27 C/H 100	6390	27	33	21	48	60	4092	4987	4564
HSK 100 A - D.27 C/H 160	6391								
HSK 100 A - D.32 C/H 100	6393	32	38	24	58	-	4093	4988	4565
HSK 100 A - D.32 C/H 160	6394								
HSK 100 A - D.40 C/H 100	6396	40	41	27	70	-	4094	4989	4566
HSK 100 A - D.40 C/H 160	6397								



TAMPONI PULITORI PER SEDE HSK CLEANERS FOR HSK SEAT



HSK	Art.
TP - HSK 32 A/C/E	5205
TP - HSK 40 A/C/E	5206
TP - HSK 50 A/C/E	5207
TP - HSK 63 A/C/E	5208
TP - HSK 80 A/C/E	5209
TP - HSK100 A/C/E	5210

TAPPI DI PROTEZIONE HSK HSK BLANKING PLUGS



HSK	Art.
ZH - HSK 63 A/C/T	6965
ZH - HSK 100 A/C/T	6975

HSK A + C

MANDRINI PER FRESE CON ATTACCO FILETTATO CHUCKS FOR MILLING CUTTERS WITH THREADED SHANK

Balanced G 6,3
20.000 rpm

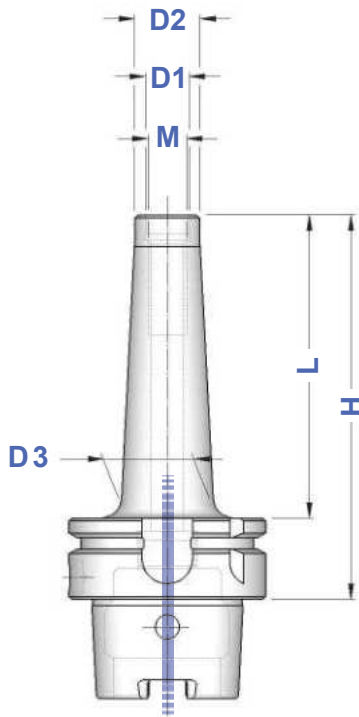

TIPO	Art.	M	D1	D2	D3	H	L
HSK 63 A - M 6 / H 59	6669	M 6	6,5	10	10	59	33
HSK 63 A - M 6 / H 84	6671				20	84	58
HSK 63 A - M 6 / H 109	6672				23	109	83
HSK 63 A - M 8 / H 59	6673	M 8	8,5	13	15	59	33
HSK 63 A - M 8 / H 76	6674				23	76	50
HSK 63 A - M 8 / H 101	6675				23	101	75
HSK 63 A - M 8 / H 126	6676				26	126	100
HSK 63 A - M 10 / H 59	6677	M 10	10,5	18	19,5	59	33
HSK 63 A - M 10 / H 76	6678				23	76	50
HSK 63 A - M 10 / H 101	6679				28	101	75
HSK 63 A - M 10 / H 126	6680				32	126	100
HSK 63 A - M 10 / H 159	6681				34	159	133
HSK 63 A - M 12 / H 59	6682	M 12	12,5	21	24	59	33
HSK 63 A - M 12 / H 76	6683				24	76	50
HSK 63 A - M 12 / H 101	6684				31	101	75
HSK 63 A - M 12 / H 126	6685				33	126	100
HSK 63 A - M 12 / H 159	6686				31	159	133
HSK 63 A - M 12 / H 184	6687				39	184	158
HSK 63 A - M 12 / H 209	6701				42	209	183
HSK 63 A - M 16 / H 59	6688	M 16	17,0	29	34	59	33
HSK 63 A - M 16 / H 76	6689				34	76	50
HSK 63 A - M 16 / H 101	6690				34	101	75
HSK 63 A - M 16 / H 126	6691				36	126	100
HSK 63 A - M 16 / H 159	6692				39	159	133
HSK 63 A - M 16 / H 184	6693				39	184	158
HSK 63 A - M 16 / H 209	6703				42	209	183
HSK 100 A - M 12 / H 87	6694	M 12	12,5	21	24	87	58
HSK 100 A - M 12 / H 137	6695				47	137	108
HSK 100 A - M 12 / H 187	6696				55	187	158
HSK 100 A - M 16 / H 87	6697	M 16	17,0	29	32	87	58
HSK 100 A - M 16 / H 137	6698				42	137	108
HSK 100 A - M 16 / H 187	6699				55	187	158
HSK 100 A - M 16 / H 237	6705				55	237	208

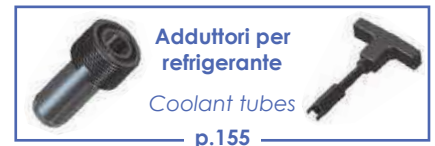

Prolunghe, Riduzioni, Portapinze ER con attacco filettato a pag. 46

Extensions, Reductions, ER Collet Chucks with threaded shank at page 46



HSK A + C

MASCHIATORI A CAMBIO RAPIDO CON DOPPIA COMPENSAZIONE

DOUBLE COMPENSATION QUICK CHANGE TAPPING CHUCKS

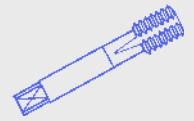

TIPO	Art.	H	E	B	COMPENSAZIONE	
HSK 40 A - B.1	6450	80	41	19	- 7,5 + 7,5	M 3 ÷ M 12 (*M18)
HSK 40 A - B.2	6451	100	60	31	- 10,0 + 10,0	M 6 ÷ M 20 (*M30)
HSK 50 A - B.1	6452	72	41	19	- 7,5 + 7,5	M 3 ÷ M 12 (*M18)
HSK 50 A - B.2	6453	130	60	31	- 10,0 + 10,0	M 6 ÷ M 20 (*M30)
HSK 63 A - B.1	6454	80	41	19	- 7,5 + 7,5	M 3 ÷ M 12 (*M18)
HSK 63 A - B.2	6455	120	60	31	- 10,0 + 10,0	M 6 ÷ M 20 (*M30)
HSK 63 A - B.3	6456	160	86	48	- 17,5 + 17,5	M14 ÷ M 33 (*M48)
HSK 100 A - B.1	6457	80	41	19	- 7,5 + 7,5	M 3 ÷ M 12 (*M18)
HSK 100 A - B.2	6458	110	60	31	- 10,0 + 10,0	M 6 ÷ M 20 (*M30)
HSK 100 A - B.3	6459	160	86	48	- 17,5 + 17,5	M14 ÷ M 33 (*M48)

* Bussole con GRANI
Adapters with SCREWS

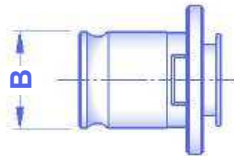
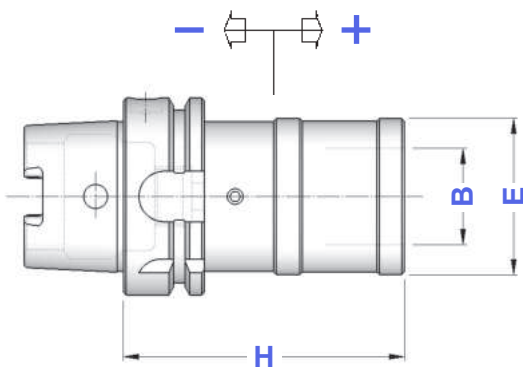

**Bussole a maschiare
da pag. 235**
Tapping Adapters
from page 235

HSK A + C

MASCHIATORI A CAMBIO RAPIDO SENZA COMPENSAZIONE

QUICK CHANGE TAPPING CHUCKS WITHOUT COMPENSATION

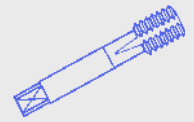

TIPO	Art.	H	E	B	
HSK 40 A - B.1 FISSO	6470	55	33	19	M 3 ÷ M 12 (*M18)
HSK 40 A - B.2 FISSO	6471	90	50	31	M 6 ÷ M 20 (*M30)
HSK 50 A - B.1 FISSO	6472	60	33	19	M 3 ÷ M 12 (*M18)
HSK 50 A - B.2 FISSO	6473	98	50	31	M 6 ÷ M 20 (*M30)
HSK 63 A - B.1 FISSO	6474	60	33	19	M 3 ÷ M 12 (*M18)
HSK 63 A - B.2 FISSO	6475	89	50	31	M 6 ÷ M 20 (*M30)
HSK 63 A - B.3 FISSO	6476	129	72	48	M14 ÷ M 33 (*M48)
HSK 100 A - B.1 FISSO	6477	70	33	19	M 3 ÷ M 12 (*M18)
HSK 100 A - B.2 FISSO	6478	90	50	31	M 6 ÷ M 20 (*M30)
HSK 100 A - B.3 FISSO	6479	115	72	48	M14 ÷ M 33 (*M48)

* Bussole con GRANI
Adapters with SCREWS

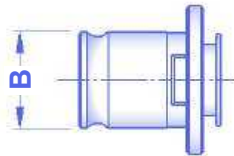
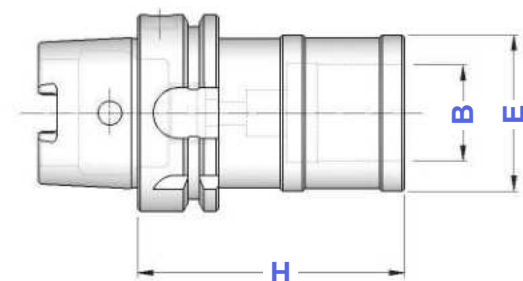

**Bussole a maschiare
da pag. 235**
Tapping Adapters
from page 235

HSK A + C

RIDUZIONI E PROLUNGHE DA HSK A HSK

HSK TO HSK ADAPTERS AND EXTENSIONS



HSK A+C ⇔ HSK A+C

TIPO	Art.	H	E
HSK 63 A+C - HSK 50 A+C	6197	80	50
HSK 63 A+C - HSK 63 A+C	6216	100	63
HSK100 A+C - HSK 63 A+C	6199	100	63
HSK100 A+C - HSK100 A+C	6217	140	100

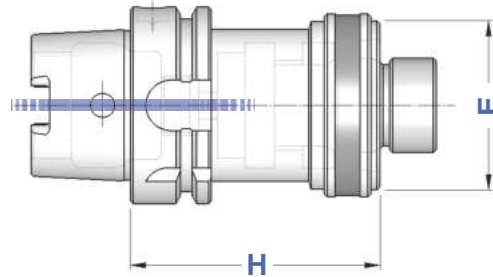

DIN 69893-1 ⇔ DIN 69893-1
(ISO 12164-1 ⇔ ISO 12164-1)

DIN 69871 ⇔ HSK A+C



p.126

BT ⇔ HSK A+C



p.154

HSK A + C

ADATTATORI DA HSK A POLIGONALE

HSK TO POLYGONAL SHANK ADAPTERS



HSK A+C ⇔ POLIGONALE

TIPO	Art.	H	E
HSK 63 A+C - POLIGONALE C 40	11051	80	40
HSK 63 A+C - POLIGONALE C 50	11052	90	50
HSK 63 A+C - POLIGONALE C 63	11053	110	63
HSK100 A+C - POLIGONALE C 40	11054	90	40
HSK100 A+C - POLIGONALE C 50	11055	100	50
HSK100 A+C - POLIGONALE C 63	11056	90	63
HSK100 A+C - POLIGONALE C 63	11057	150	63
HSK100 A+C - POLIGONALE C 80	11058	120	80

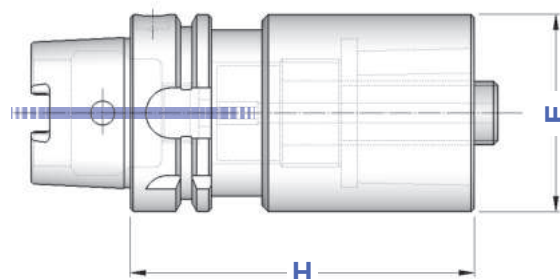

DIN 69893-1 ⇔ ISO 26623-1
(ISO 12164-1 ⇔ ISO 26623-1)

INDICE DELL' ATTACCO HSK T (DIN 69893 T / ISO 12164-3)

INDEX OF HSK T SHANK (DIN 69893 T / ISO 12164 -3)

**PORTAUTENSILE
ASSIALE DESTRO**RIGHT HAND AXIAL
TOOLHOLDER

pag. 176

**PORTAUTENSILE
ASSIALE SINISTRO**LEFT HAND AXIAL
TOOLHOLDER

pag. 176

**PORTAUTENSILE ASSIALE
TRIPLO DESTRO**TRIPLE RIGHT HAND
AXIAL TOOLHOLDER

pag. 177

**PORTAUTENSILE ASSIALE
TRIPLO SINISTRO**TRIPLE LEFT HAND
AXIAL TOOLHOLDER

pag. 177

**ASSIALE DESTRO
RIBALTABILE SINISTRO**RIGHT HAND AXIAL TOOLHOLDER
OVERTURNABLE LEFT HAND

pag. 178

 **α 45° SINISTRO
RIBALTABILE DESTRO**LEFT HAND 45° TOOLHOLDER
OVERTURNABLE RIGHT HAND

pag. 178

**PORTAUTENSILE α 45°
DESTRO**45° RIGHT HAND
TOOLHOLDER

pag. 179

**PORTAUTENSILE α 45°
SINISTRO**45° LEFT HAND
TOOLHOLDER

pag. 179

**PORTABARENI**

BORING BAR HOLDERS

pag. 180

**PORTAUTENSILE RADIALE
DESTRO - SINISTRO**RIGHT - LEFT HAND
RADIAL TOOLHOLDER

pag. 180

**PORTALAMA
DESTRO**RIGHT AXIAL TOOLHOLDERS
for CUT OFF TOOLS

pag. 181

**PORTALAMA
SINISTRO**LEFT AXIAL TOOLHOLDERS
for CUT OFF TOOLS

pag. 181

**PORTA PUNTE ad INSERTI
(HSK A+C)**

INDEXABLE DRILL HOLDERS

pag. 163

**TAPPO di PROTEZIONE
(HSK A+C)**

BLANKING PLUGS

pag. 171



HSK T

PORTAUTENSILE ASSIALE DESTRO

RIGHT HAND AXIAL TOOLHOLDER

DIN 69893 T
DIN ISO 12164-3
ICTM standard
HSK A+C compatible

TIPO	Art.	d1	b1	b2	h	h1	h2	L
HSK 63T - A25R	6906	63	32	10	25	25	50	125

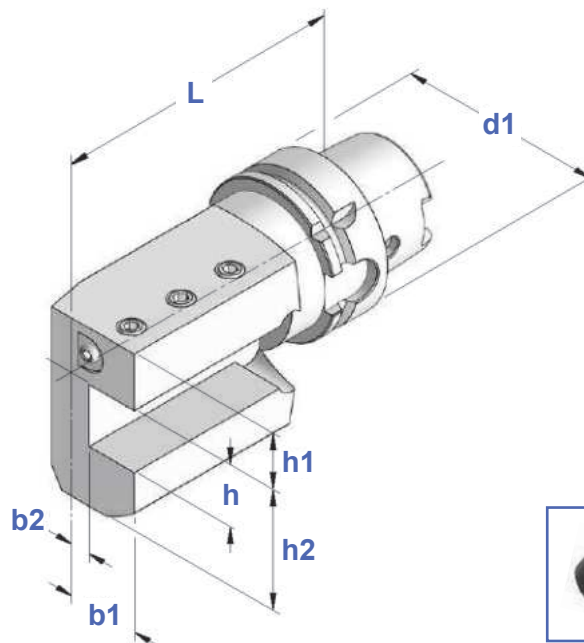

HSK T

PORTAUTENSILE ASSIALE SINISTRO

LEFT HAND AXIAL TOOLHOLDER

DIN 69893 T
DIN ISO 12164-3
ICTM standard
HSK A+C compatible

TIPO	Art.	d1	b1	b2	h	h1	h2	L
HSK 63T - A25L	6907	63	32	10	25	25	50	125

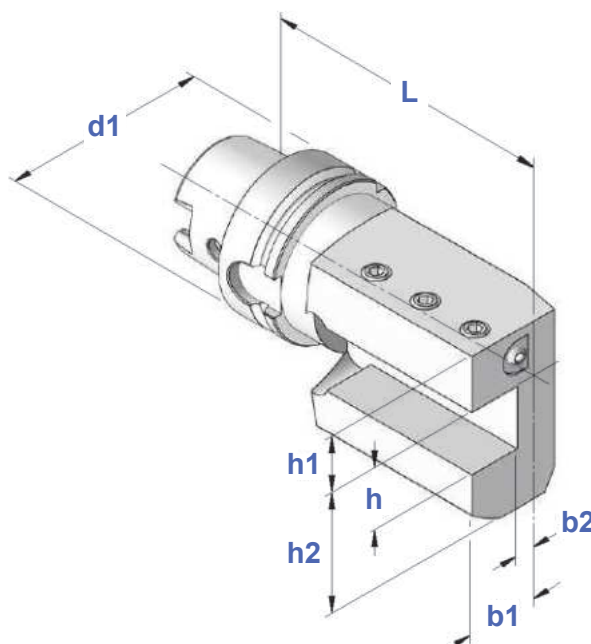

HSK T

PORTAUTENSILE ASSIALE TRIPLO - DESTRO
TRIPLE RIGHT HAND AXIAL TOOLHOLDER

DIN 69893 T
DIN ISO 12164-3
ICTM standard
HSK A+C compatible

TIPO	Art.	d1	D	b1	b2	h	L
HSK 63T - AT20R	6909	63	90	36	16	20	125

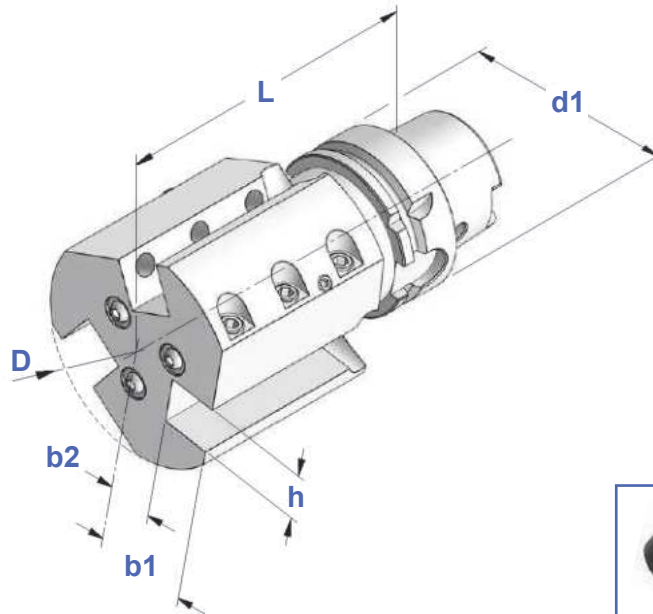

HSK T

PORTAUTENSILE ASSIALE TRIPLO - SINISTRO
TRIPLE LEFT HAND AXIAL TOOLHOLDER

DIN 69893 T
DIN ISO 12164-3
ICTM standard
HSK A+C compatible

TIPO	Art.	d1	D	b1	b2	h	L
HSK 63T - AT20L	6910	63	90	36	16	20	125

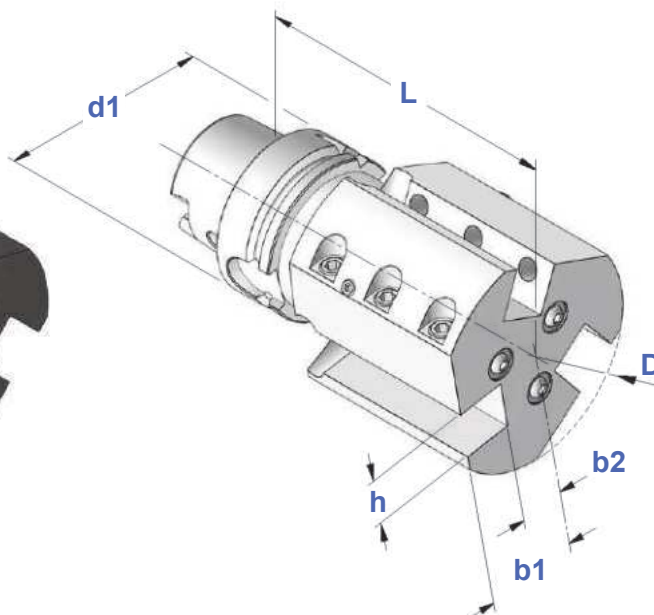

HSK T

PORTAUTENSILE ASSIALE DESTRO - RIBALTABILE SINISTRO
 RIGHT HAND AXIAL TOOLHOLDER - OVERTURNABLE LEFT HAND

DIN 69893 T
 DIN ISO 12164-3
 ICTM standard
 HSK A+C compatible

TIPO	Art.	d1	b1	b2	h	h1	L
HSK 63T - A25RL	6911	63	58	32	25	45	102

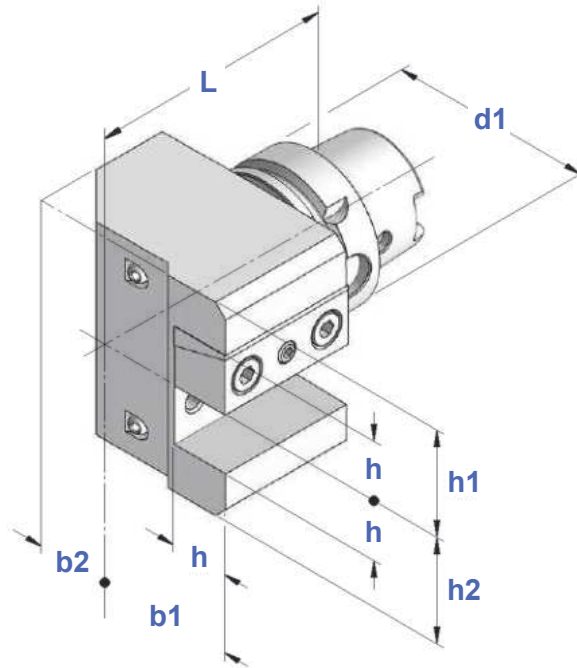

HSK T

PORTAUTENSILE A 45° SINISTRO - RIBALTABILE DESTRO
 LEFT HAND 45° TOOLHOLDER - OVERTURNABLE RIGHT HAND

DIN 69893 T
 DIN ISO 12164-3
 ICTM standard
 HSK A+C compatible

TIPO	Art.	d1	b1	b2	h	h1	L
HSK 63T - U25LR	6943	63	35	70	25	45	117,4

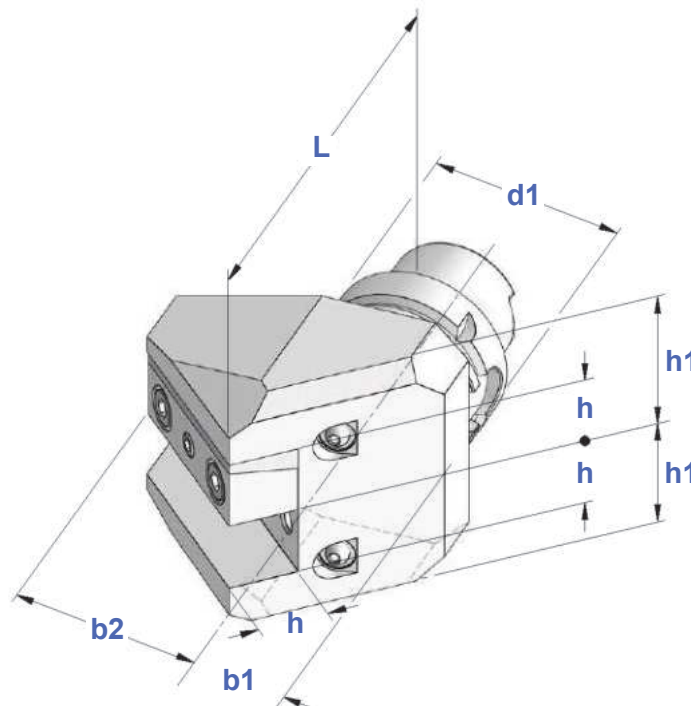

HSK T**PORTAUTENSILE A 45° DESTRO**

45° RIGHT HAND TOOLHOLDER

DIN 69893 T
 DIN ISO 12164-3
 ICTM standard
 HSK A+C compatible

TIPO	Art.	d1	D	h	h1	h2	L
HSK 63T - U25R	6944	63	105	25	22	25	120

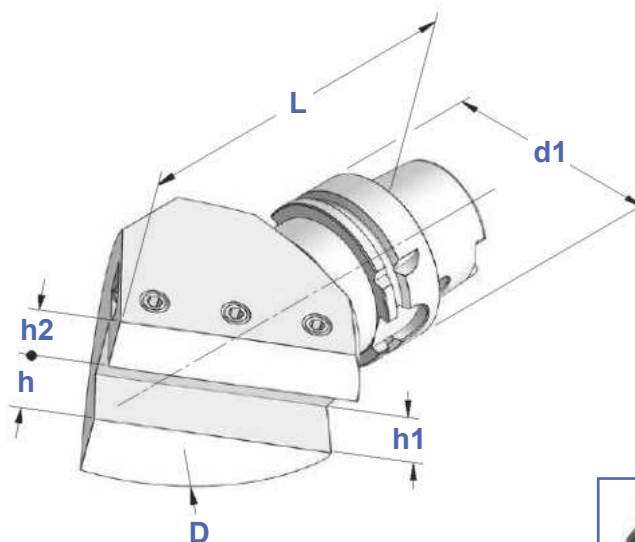
**HSK T****PORTAUTENSILE A 45° SINISTRO**

45° LEFT HAND TOOLHOLDER

DIN 69893 T
 DIN ISO 12164-3
 ICTM standard
 HSK A+C compatible

TIPO	Art.	d1	D	h	h1	h2	L
HSK 63T - U25L	6945	63	105	25	22	25	120

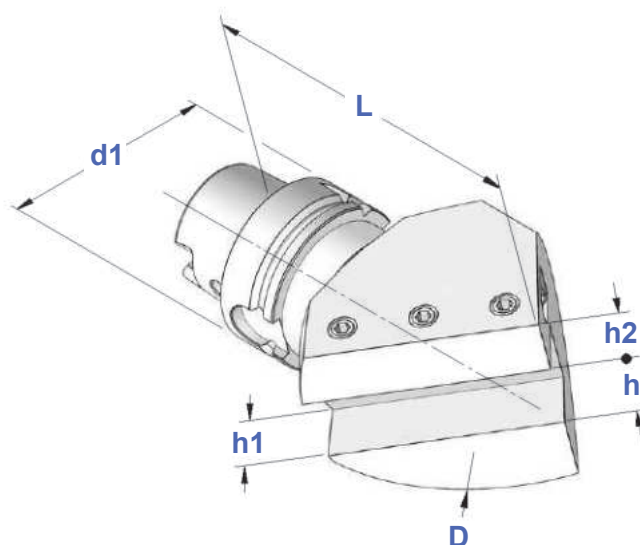

HSK T

PORTABARENI CON REFRIGERAZIONE INTERNA - ESTERNA BORING BAR HOLDER WITH INSIDE - OUTSIDE COOLING

DIN 69893 T
DIN ISO 12164-3
ICTM standard
HSK A+C compatible



TIPO	Art.	d1	D	E	H	L
HSK 63T - D.08 PB	6948	63	8	32	70	40
HSK 63T - D.10 PB	6949	63	10	38	75	45
HSK 63T - D.12 PB	6950	63	12	40	75	45
HSK 63T - D.16 PB	6951	63	16	45	80	50
HSK 63T - D.20 PB	6952	63	20	50	80	50
HSK 63T - D.25 PB	6953	63	25	55	85	52
HSK 63T - D.32 PB	6954	63	32	72	95	58
HSK 63T - D.40 PB	6955	63	40	80	120	72

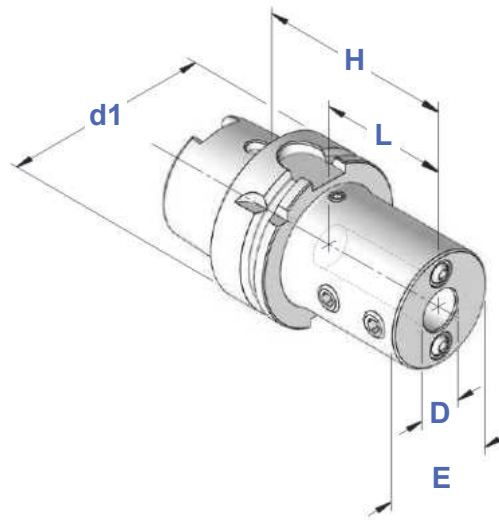

Bussole di riduzione
Reduction sleeves



HSK T

PORTAUTENSILE RADIALE DESTRO - SINISTRO RIGHT - LEFT HAND RADIAL TOOLHOLDER

DIN 69893 T
DIN ISO 12164-3
ICTM standard
HSK A+C compatible

TIPO	Art.	d1	d2	D	b1	h	h1	L	L2
HSK 63T - R32/25RL	6964	63	130	340	50	32/25	32,5	85	50

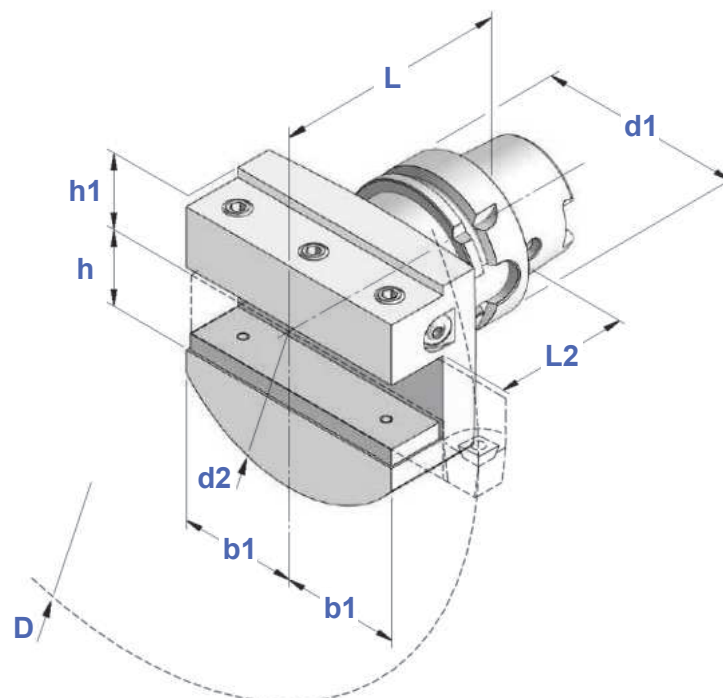

HSK T

PORTALAMA DESTRO RIGHT AXIAL TOOLHOLDER FOR CUT OFF TOOLS

DIN 69893 T
DIN ISO 12164-3
ICTM standard
HSK A+C compatible

TIPO	Art.	d1	b1	b2	h	h1	h2	h3	L
HSK 63T - C26R	6960	63	38	32	26	21,4	34	30	115
HSK 63T - C32R	6961	63	38	32	32	25	38	33	150

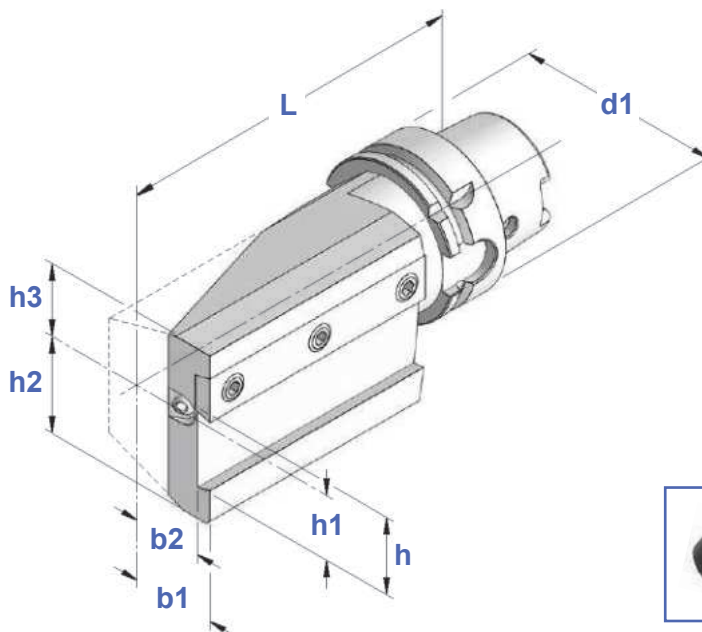

HSK T

PORTALAMA SINISTRO LEFT AXIAL TOOLHOLDER FOR CUT OFF TOOLS

DIN 69893 T
DIN ISO 12164-3
ICTM standard
HSK A+C compatible

TIPO	Art.	d1	b1	b2	h	h1	h2	h3	L
HSK 63T - C26L	6962	63	38	32	26	21,4	34	30	115
HSK 63T - C32L	6963	63	38	32	32	25	38	33	150

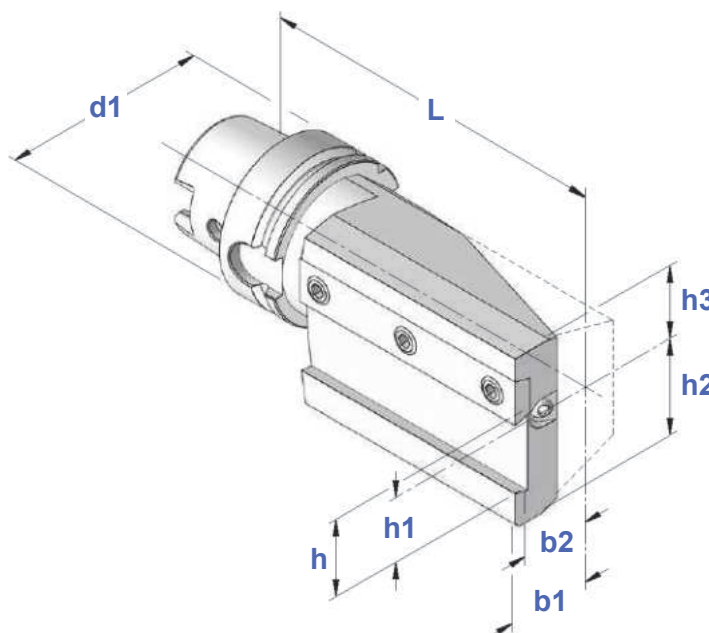

CARATTERISTICHE TECNICHE HSK E (DIN 69893-5 / ISO 12164-1)

HSK E (DIN 69893-5 / ISO 12164-1) STANDARD FEATURES

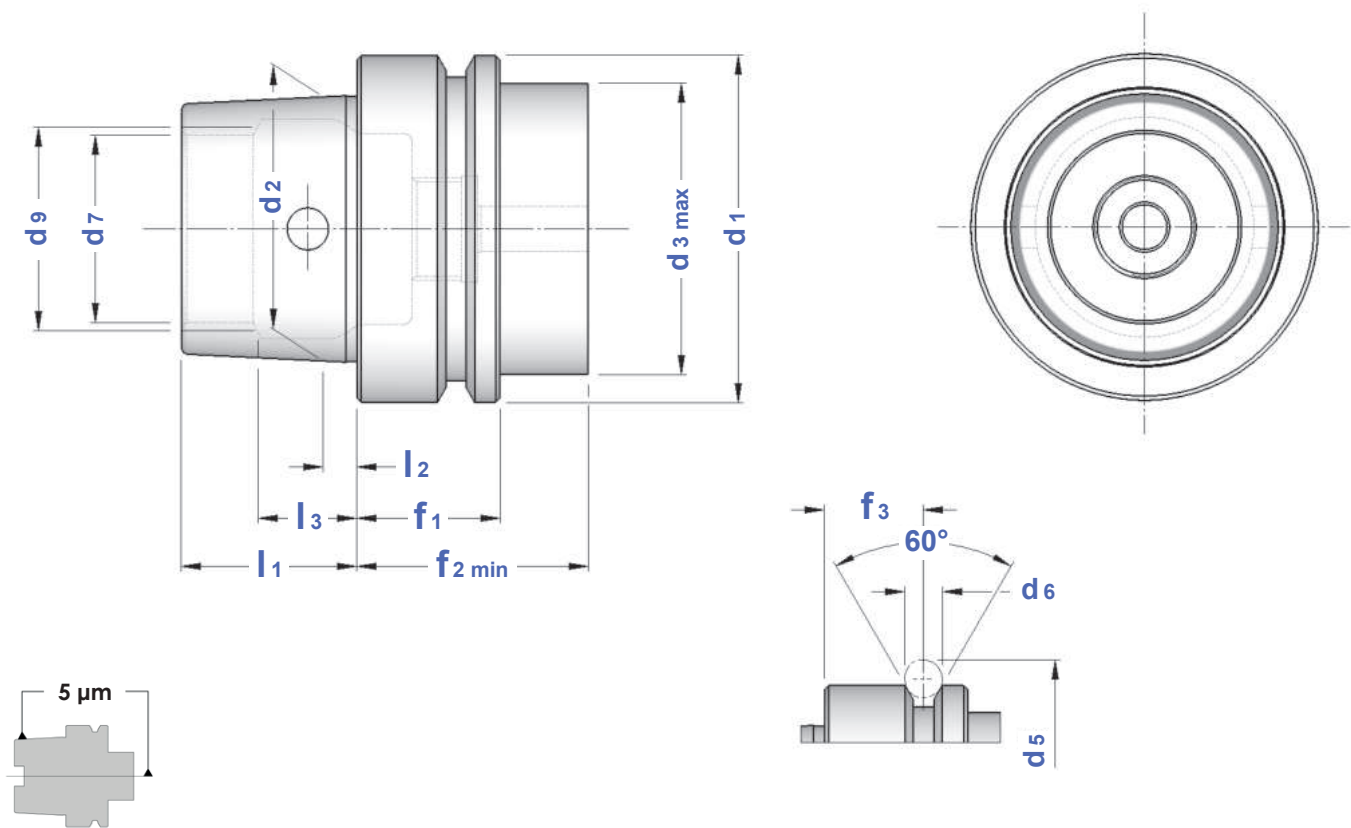

CONO	d1	d2	d3	d5	d6	d7	d9	f1	f2	f3	l1	l2	l3
HSK 25 E	25	19	20	28,5	3	14	15	10	20	4,5	13	2,5	7,21
HSK 32 E	32	24	26	37,0	4	17	19	20	35	16	16	3,2	8,92
HSK 40 E	40	30	34	45,0	4	21	23	20	35	16	20	4,0	11,42
HSK 50 E	50	38	42	59,3	7	26	29	26	42	18	25	5,0	14,13
HSK 63 E	63	48	53	72,3	7	34	37	26	42	18	32	6,3	18,13

ADDUTTORI PER REFRIGERANTE
COOLANT TUBES

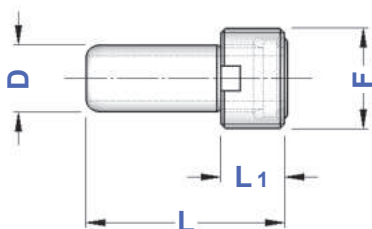

Gli adduttori sono forniti completi di OR
Coolant tubes are supplied complete with O-Ring



OR
O-RING

CHIAVE
WRENCH

Art.	HSK	F	D	L	L1	O-RING	CHIAVE WRENCH
0413	HSK 32 E	M 10 x 1	6	26,0	5,5	5668	0470
0414	HSK 40 E	M 12 x 1	8	29,3	7,5	5672	0471
0415	HSK 50 E	M 16 x 1	10	33,0	9,5	5673	0472
0416	HSK 63 E	M 18 x 1	12	36,6	11,5	5674	0473

INDICE DELL' ATTACCO HSK E (DIN 69893-5 / ISO 12164-1)

INDEX OF HSK E SHANK (DIN 69893-5 / ISO 12164 -1)

**PORTAPINZA ER
ghiera MINI**ER MINI NUT
COLLET CHUCKS
pag. 184**PORTAPINZA ER
ghiera STANDARD**ER STANDARD NUT
COLLET CHUCKS
pag. 184**PORTAFRESE WELDON**END MILL HOLDERS
for DIN 1835-B SHANK

pag. 185

**BARRE a STELO TENERO**

BLANK BARS

pag. 185

**riduzioni a CONO MORSE
per PUNTE**

MT ADAPTERS for Twist Drills

pag. 186

**riduzioni a CONO MORSE
per FRESE**

MT ADAPTERS for Milling Cutters

pag. 186

**PORTAFRESE FISSI**

FACE MILL HOLDERS

pag. 187

**PORTA FRESE con
ATTACCO FILETTATO**THREADED SHANK
MILLING CUTTERS HOLDERS
pag. 188**ADDUTTORI per
REFRIGERANTE e CHIAVI**COOLANT TUBES
and WRENCHES
pag. 182**TAMPONI PULITORI
per SEDE HSK**

CLEANERS for HSK SEAT

pag. 243

**SMONTACONI
ORIENTABILI**ORIENTABLE
TIGHTENING FIXTURES
pag. 241**MAGAZZINI PORTACONI**

TOOL STORES

pag. 244 - 245





HSK E

PORTAPINZA ER - GHIERA MINI ER COLLET CHUCKS with MINI NUT

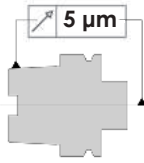
Balanced G 2,5
20.000 rpm



TIPO	Art.	D	RANGE			
HSK 25 E - ER 16 GM/H 43	6610	22	ER16 1÷12	1229	5719	0364
HSK 32 E - ER 16 GM/H 60	6612	22	ER16 1÷12	1229	5719	0364
HSK 32 E - ER 25 GM/H 60	6614	35	ER25 1÷20	1231	5721	0996
HSK 40 E - ER 16 GM/H 70	6500	22	ER16 1÷12	1229	5719	0364
HSK 40 E - ER 16 GM/H 120	6502					
HSK 40 E - ER 25 GM/H 80	6508	35	ER25 1÷20	1231	5721	0996
HSK 50 E - ER 16 GM/H 100	6513	22	ER16 1÷12	1229	5719	0364
HSK 50 E - ER 16 GM/H 160	6514					
HSK 63 E - ER 16 GM/H 100	6521	22	ER16 1÷12	1229	5719	0364
HSK 63 E - ER 16 GM/H 160	6523					

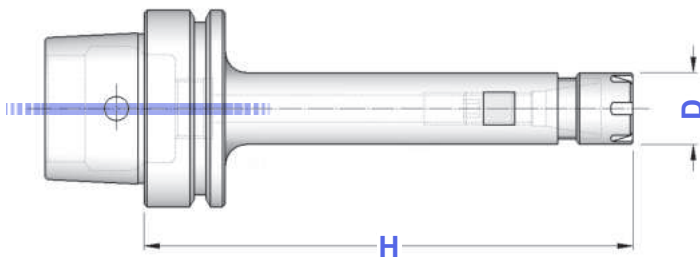



HSK E

PORTAPINZA ER - GHIERA STANDARD ER COLLET CHUCKS with STANDARD NUT

Balanced G 2,5
20.000 rpm



TIPO	Art.	D	RANGE			
HSK 40 E - ER 32/H 65	6526	50	ER32 2÷25	4996	3670	0988
HSK 50 E - ER 25/H 100	6537	42	ER25 1÷20	4995	3669	0996
HSK 50 E - ER 32/H 100	6539	50	ER32 2÷25	4996	3670	0988
HSK 50 E - ER 32/H 160	6541					
HSK 50 E - ER 40/H 100	6542	63	ER40 3÷32	4997	3671	0821
HSK 63 E - ER 25/H 70	6543	42	ER25 1÷20	4995	3669	0996
HSK 63 E - ER 25/H 100	6544					
HSK 63 E - ER 32/H 75	6545	50	ER32 2÷25	4996	3670	0988
HSK 63 E - ER 32/H 100	6546					
HSK 63 E - ER 32/H 160	6548					
HSK 63 E - ER 40/H 80	6550	63	ER40 3÷32	4997	3671	0821
HSK 63 E - ER 40/H 120	6552					

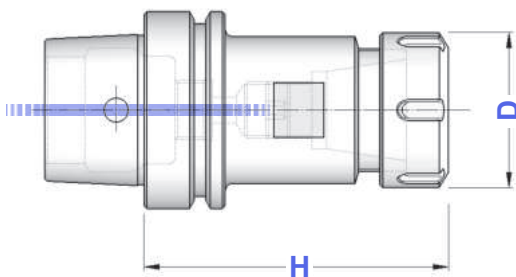

HSK E

PORTAFRESE WELDON END MILL HOLDERS FOR DIN 1835-B SHANKS



Balanced G 2,5
20.000 rpm



WE 6 ÷ WE 20
1 grano
1 screw



WE 25 ÷ WE 32
2 grani
2 screws

TIPO	Art.	D	H	E	
HSK 50 E - WE 6 / H 65	6616	6	65	25	4970
HSK 50 E - WE 8 / H 65	6619	8	65	28	4971
HSK 50 E - WE 10 / H 65	6622	10	65	35	4972
HSK 50 E - WE 12 / H 80	6625	12	80	42	4973
HSK 50 E - WE 14 / H 80	6628	14	80	44	4973
HSK 50 E - WE 16 / H 80	6631	16	80	48	4974
HSK 50 E - WE 18 / H 80	6634	18	80	50	4974
HSK 50 E - WE 20 / H 80	6637	20	80	52	4975
HSK 50 E - WE 25 / H 105	6640	25	105	65	4976
HSK 63 E - WE 6 / H 65	6643	6	65	25	4970
HSK 63 E - WE 8 / H 65	6646	8	65	28	4971
HSK 63 E - WE 10 / H 70	6649	10	70	35	4972
HSK 63 E - WE 12 / H 80	6652	12	80	42	4973
HSK 63 E - WE 14 / H 80	6655	14	80	44	4973
HSK 63 E - WE 16 / H 80	6658	16	80	48	4974
HSK 63 E - WE 18 / H 80	6661	18	80	50	4974
HSK 63 E - WE 20 / H 80	6664	20	80	52	4975
HSK 63 E - WE 25 / H 105	6667	25	105	65	4976
HSK 63 E - WE 32 / H 110	6670	32	110	72	4977

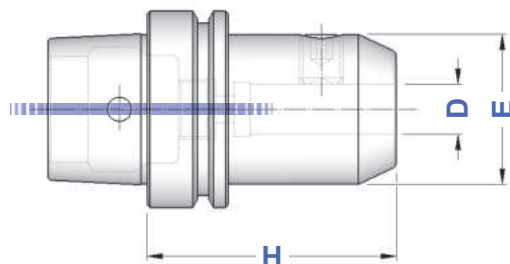

Adduttori per refrigerante
Coolant tubes

HSK E

BARRE A STELO TENERO BLANK BARS

HSK

TIPO	Art.	D	H
HSK 50 E - D. 63 ST	6946	63	200
HSK 63 E - D. 63 ST	6947	63	200



HSK E

RIDUZIONI A CONO MORSE PER PUNTE

MT ADAPTERS FOR TWIST DRILLS

Balanced G 6,3

8.000 rpm



TIPO	Art.	CM	H	E
HSK 50 E - CM 1 PUNTE	6802	1	100	25
HSK 50 E - CM 2 PUNTE	6803	2	120	32
HSK 50 E - CM 3 PUNTE	6804	3	140	40
HSK 63 E - CM 1 PUNTE	6805	1	100	25
HSK 63 E - CM 2 PUNTE	6806	2	120	32
HSK 63 E - CM 3 PUNTE	6807	3	140	40
HSK 63 E - CM 4 PUNTE	6808	4	165	48

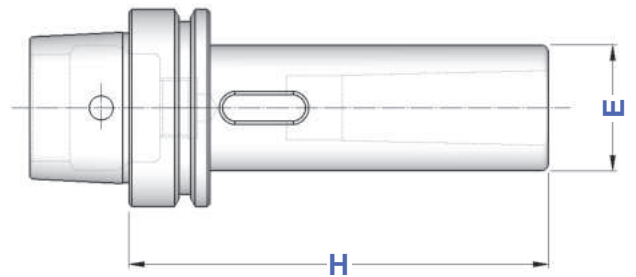

HSK E



RIDUZIONI A CONO MORSE PER FRESE

MT ADAPTERS FOR MILLING CUTTERS

Balanced G 6,3

8.000 rpm



TIPO	Art.	CM	H	E		
HSK 50 E - CM 1 FRESE	6817	1	105	25	7420	4568
HSK 50 E - CM 2 FRESE	6818	2	120	32	7422	4569
HSK 50 E - CM 3 FRESE	6819	3	140	40	7423	4570
HSK 63 E - CM 1 FRESE	6820	1	100	25	7420	4568
HSK 63 E - CM 2 FRESE	6821	2	125	32	7422	4569
HSK 63 E - CM 3 FRESE	6822	3	145	40	7423	4570
HSK 63 E - CM 4 FRESE	6823	4	165	48	7424	4571

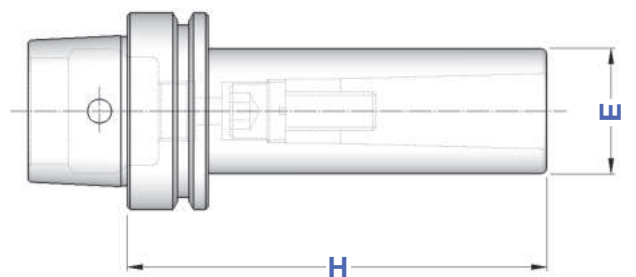

HSK E

PORTAFRESE FISSI FACE MILL HOLDERS

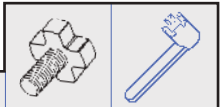

Balanced G 2,5
20.000 rpm



TIPO	Art.	D	L	E		
HSK 40 E - D. 16 FISSO/ H 45	6850	16	17	38	4985	4562
HSK 40 E - D. 22 FISSO/ H 50	6851	22	19	48	4986	4563
HSK 50 E - D. 16 FISSO/ H 50	6853	16	17	38	4985	4562
HSK 50 E - D. 22 FISSO/ H 60	6855	22	19	48	4986	4563
HSK 50 E - D. 27 FISSO/ H 60	6857	27	21	58	4987	4564
HSK 50 E - D. 32 FISSO/ H 60	6859	32	24	66	4988	4565
HSK 50 E - D. 40 FISSO/ H 70	6860	40	27	80	4989	4566
HSK 63 E - D. 16 FISSO/ H 50	6861	16	17	38	4985	4562
HSK 63 E - D. 16 FISSO/ H 100	6862					
HSK 63 E - D. 22 FISSO/ H 50	6863	22	19	48	4986	4563
HSK 63 E - D. 22 FISSO/ H 100	6864					
HSK 63 E - D. 27 FISSO/ H 60	6865	27	21	58	4987	4564
HSK 63 E - D. 27 FISSO/ H 100	6866					
HSK 63 E - D. 32 FISSO/ H 60	6867	32	24	66	4988	4565
HSK 63 E - D. 32 FISSO/ H 100	6868					
HSK 63 E - D. 40 FISSO/ H 65	6869	40	27	80	4989	4566
HSK 63 E - D. 40 FISSO/ H 100	6870					

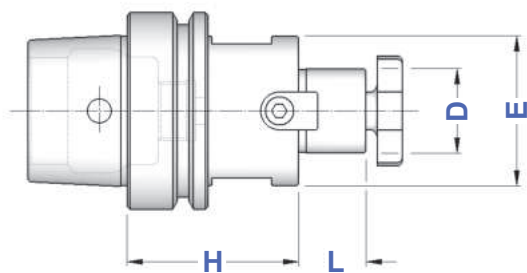

Aperto
Open



Chiuso
Closed



Smontaconi orientabili HSK a pagina 241
Il bloccaggio del mandrino avviene sulla flangia mediante la chiusura a morsa
Orientable HSK Tightening Fixture on page 241
The spindle is locked on the flange by means of vise closure

HSK E

MANDRINI PER FRESE CON ATTACCO FILETTATO CHUCKS FOR MILLING CUTTERS WITH THREADED SHANK

Balanced G 2,5
20.000 rpm



TIPO	Art.	M	D1	D2	D3	H	L
HSK 63 E - M 6 / H 59	6573	M 6	6,5	10	10	59	33
HSK 63 E - M 6 / H 84	6574				20	84	58
HSK 63 E - M 6 / H 109	6575				23	109	83
HSK 63 E - M 8 / H 59	6576	M 8	8,5	13	15	59	33
HSK 63 E - M 8 / H 84	6577				23	84	50
HSK 63 E - M 8 / H 109	6578				23	109	75
HSK 63 E - M 8 / H 134	6579				26	134	100
HSK 63 E - M 10 / H 59	6580	M 10	10,5	18	19,5	59	33
HSK 63 E - M 10 / H 84	6581				23	84	50
HSK 63 E - M 10 / H 109	6582				28	109	75
HSK 63 E - M 10 / H 134	6583				32	134	100
HSK 63 E - M 12 / H 59	6584	M 12	12,5	21	24	59	33
HSK 63 E - M 12 / H 84	6585				24	84	50
HSK 63 E - M 12 / H 109	6586				31	109	75
HSK 63 E - M 12 / H 134	6587				33	134	100
HSK 63 E - M 12 / H 159	6588				31	159	133
HSK 63 E - M 16 / H 59	6589	M 16	17,0	29	34	59	33
HSK 63 E - M 16 / H 84	6590				34	84	50
HSK 63 E - M 16 / H 109	6591				34	109	75
HSK 63 E - M 16 / H 134	6592				36	134	100
HSK 63 E - M 16 / H 159	6593				39	159	133

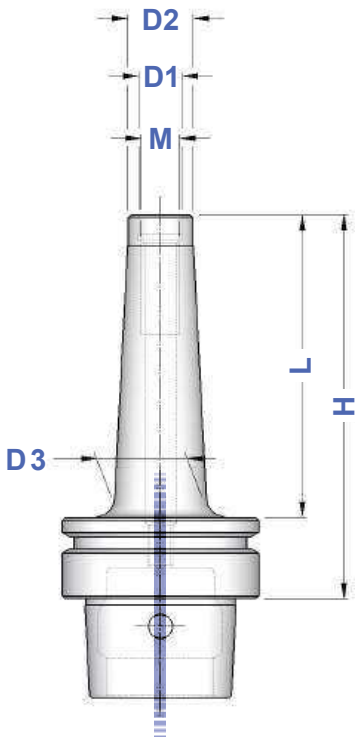

Prolunghe, Riduzioni, Portapinze ER con attacco filettato a pag. 46

Extensions, Reductions, ER Collet Chucks with threaded shank at page 46



CARATTERISTICHE TECNICHE HSK F (DIN 69893-6 / ISO 12164-1)

HSK F (DIN 69893-6 / ISO 12164-1) STANDARD FEATURES

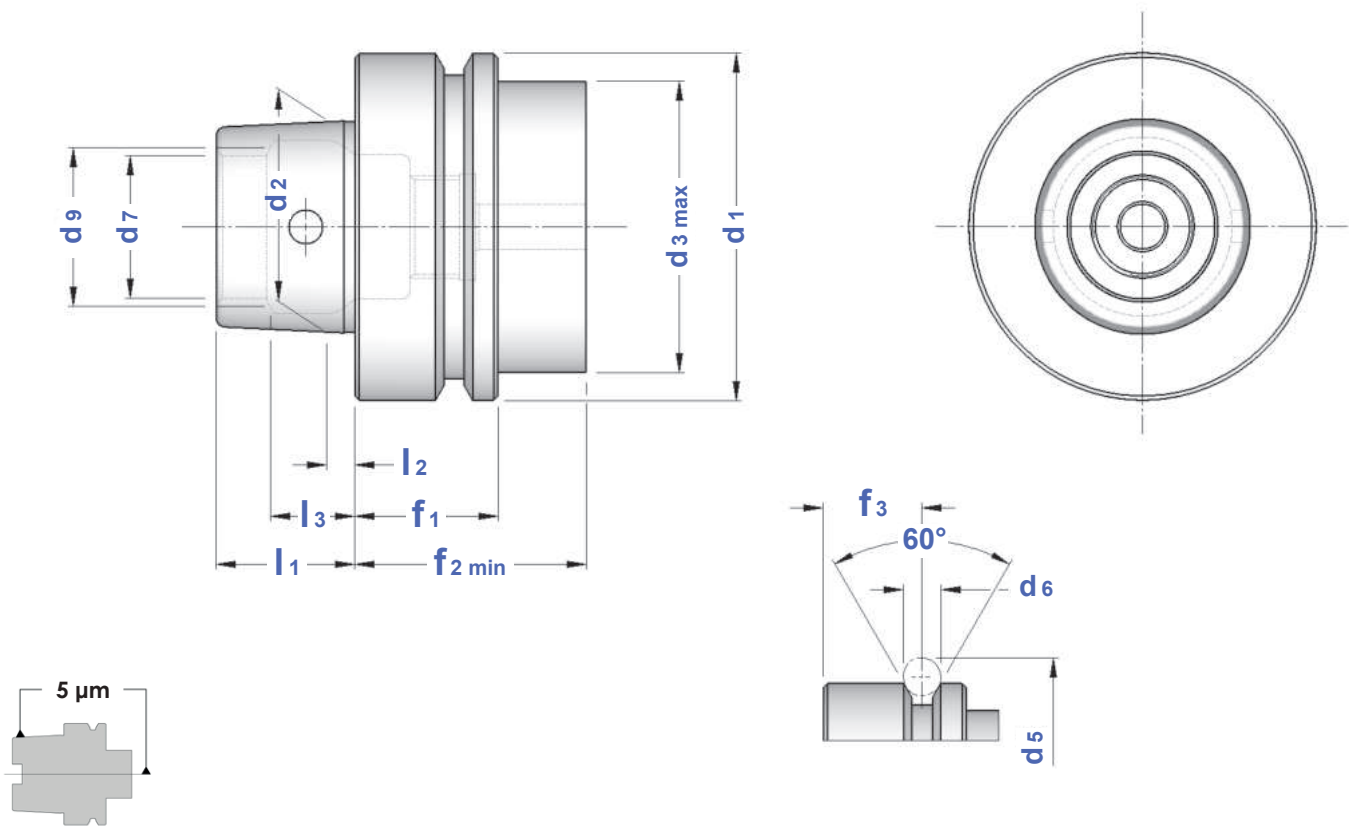

CONO	d1	d2	d3	d5	d6	d7	d9	f1	f2	f3	l1	l2	l3
HSK 50 F	50	30	42	59,3	7	21	23	26	42	18	20	4	11,42
HSK 63 F	63	38	53	72,3	7	26	29	26	42	18	25	5	14,13
HSK 80 F	80	48	68	88,8	7	34	37	26	42	18	32	6,3	18,13

ADDUTTORI PER REFRIGERANTE
COOLANT TUBES

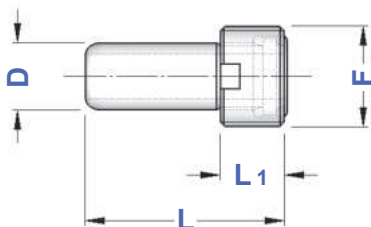

Gli adduttori sono forniti completi di OR
Coolant tubes are supplied complete with O-Ring

Art.	HSK	F	D	L	L1	OR O-RING	CHIAVE WRENCH
0414	HSK 50 F	M 12 x 1	8	29,3	7,5	5672	0471
0415	HSK 63 F	M 16 x 1	10	33,0	9,5	5673	0472

INDICE DELL' ATTACCO HSK F (DIN 69893-6 / ISO 12164-1)

INDEX OF HSK F SHANK (DIN 69893-6 / ISO 12164 -1)

**PORTAPINZA ER
ghiera MINI**ER MINI NUT
COLLET CHUCKS
pag. 191**PORTAPINZA ER
ghiera STANDARD**ER STANDARD NUT
COLLET CHUCKS
pag. 191**PORTAFRESE WELDON**END MILL HOLDERS
for DIN 1835-B SHANK

pag. 192

**BARRE a STELO TENERO**

BLANK BARS

pag. 193

**BARRE di CONTROLLO**

TEST ARBORS

pag. 193

**riduzioni a CONO MORSE
per PUNTE**

MT ADAPTERS for Twist Drills

pag. 194

**riduzioni a CONO MORSE
per FRESE**

MT ADAPTERS for Milling Cutters

pag. 194

**PORTAFRESE FISSI**

FACE MILL HOLDERS

pag. 195

**PORTAFRESE COMBINATI**COMBI
SHELL MILL HOLDERS

pag. 195

**PORTA FRESE con
ATTACCO FILETTATO**THREADED SHANK
MILLING CUTTERS HOLDERS
pag. 196**ADDUTTORI per
REFRIGERANTE e CHIAVI**COOLANT TUBES
and WRENCHES
pag. 189**SMONTACONI
ORIENTABILI**ORIENTABLE
TIGHTENING FIXTURES
pag. 241**MAGAZZINI PORTACONI**TOOL STORES
pag. 244 - 245



HSK F

PORTAPINZA ER - GHIERA MINI

ER COLLET CHUCKS with MINI NUT

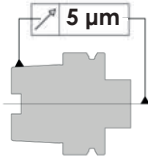
Balanced G 2,5
20.000 rpm



TIPO	Art.	D	RANGE			
HSK 50 F - ER 16 GM/H 80 HSK 50 F - ER 16 GM/H 100	6756 6854	22	ER16 1÷12	1229	5719	0364
HSK 63 F - ER 16 GM/H 100 HSK 63 F - ER 16 GM/H 160	6759 6760	22	ER16 1÷12	1229	5719	0364
HSK 63 F - ER 20 GM/H 100	6856	28	ER20 1÷15	1230	5720	0787
HSK 63 F - ER 25 GM/H 100 HSK 63 F - ER 25 GM/H 160	6858 6761	35	ER25 1÷20	1231	5721	0996

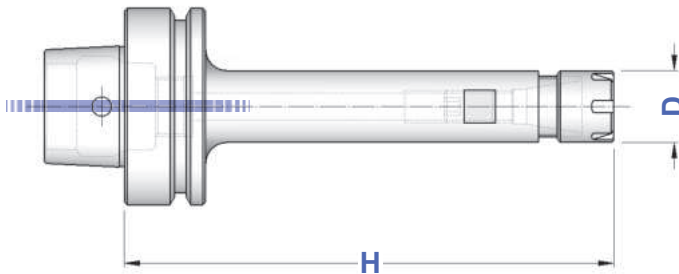





HSK F

PORTAPINZA ER - GHIERA STANDARD

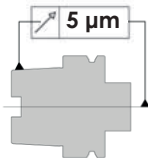
ER COLLET CHUCKS with STANDARD NUT

Balanced G 2,5
20.000 rpm



TIPO	Art.	D	RANGE			
HSK 50 F - ER 25/H 73 HSK 50 F - ER 25/H 100	6762 6791	42	ER25 1÷20	4995	3669	0996
HSK 50 F - ER 32/H 73 HSK 50 F - ER 32/H 100	6602 6763	50	ER32 2÷25	4996	3670	0988
HSK 50 F - ER 40/H 100	6764	63	ER40 3÷32	4997	3671	0821
HSK 63 F - ER 16/H 100 HSK 63 F - ER 16/H 120 HSK 63 F - ER 16/H 160	6792 6793 6794	32	ER16 1÷12	4993	3698	0364
HSK 63 F - ER 20/H 100 HSK 63 F - ER 20/H 120 HSK 63 F - ER 20/H 160	6795 6796 6797	35	ER20 1÷15	4994	3699	0787
HSK 63 F - ER 25/H 73 HSK 63 F - ER 25/H 100 HSK 63 F - ER 25/H 120 HSK 63 F - ER 25/H 160	6604 6765 6798 6799	42	ER25 1÷20	4995	3669	0996
HSK 63 F - ER 32/H 73 HSK 63 F - ER 32/H 100 HSK 63 F - ER 32/H 120 HSK 63 F - ER 32/H 160	6606 6766 6809 6767	50	ER32 2÷25	4996	3670	0988
HSK 63 F - ER 40/H 80 HSK 63 F - ER 40/H 120 HSK 63 F - ER 40/H 160	6768 6769 6810	63	ER40 3÷32	4997	3671	0821

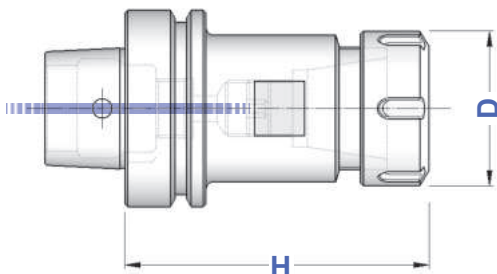

HSK F

PORTAFRESE WELDON END MILL HOLDERS FOR DIN 1835-B SHANKS



Balanced G 2,5
20.000 rpm



WE6 ÷ WE20
1 grano
1 screw



WE25 ÷ WE32
2 grani
2 screws

TIPO	Art.	D	H	E	
HSK 50 F - WE 6 / H 65	6077	6	65	25	4970
HSK 50 F - WE 8 / H 65	6078	8	65	28	4971
HSK 50 F - WE 10 / H 70	6079	10	70	35	4972
HSK 50 F - WE 12 / H 80	6080	12	80	42	4973
HSK 50 F - WE 14 / H 80	6748	14	80	44	4973
HSK 50 F - WE 16 / H 80	6081	16	80	48	4974
HSK 50 F - WE 18 / H 80	6750	18	80	50	4974
HSK 50 F - WE 20 / H 80	6082	20	80	52	4975
HSK 50 F - WE 25 / H 105	6758	25	105	65	4976
HSK 63 F - WE 6 / H 65	6083	6	65	25	4970
HSK 63 F - WE 8 / H 65	6084	8	65	28	4971
HSK 63 F - WE 10 / H 65	6085	10	65	35	4972
HSK 63 F - WE 12 / H 80	6086	12	80	42	4973
HSK 63 F - WE 14 / H 80	6832	14	80	44	4973
HSK 63 F - WE 16 / H 80	6087	16	80	48	4974
HSK 63 F - WE 18 / H 80	6835	18	80	50	4974
HSK 63 F - WE 20 / H 80	6088	20	80	52	4975
HSK 63 F - WE 25 / H 110	6089	25	110	65	4976
HSK 63 F - WE 32 / H 110	6839	32	110	72	4977

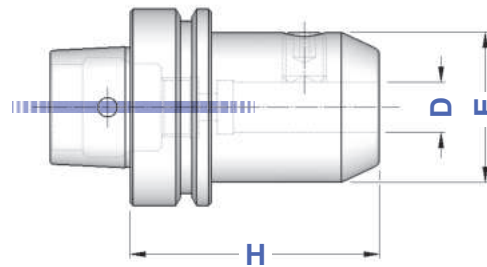

Accessori per Portafrese Weldon Accessories for End Mill Holders

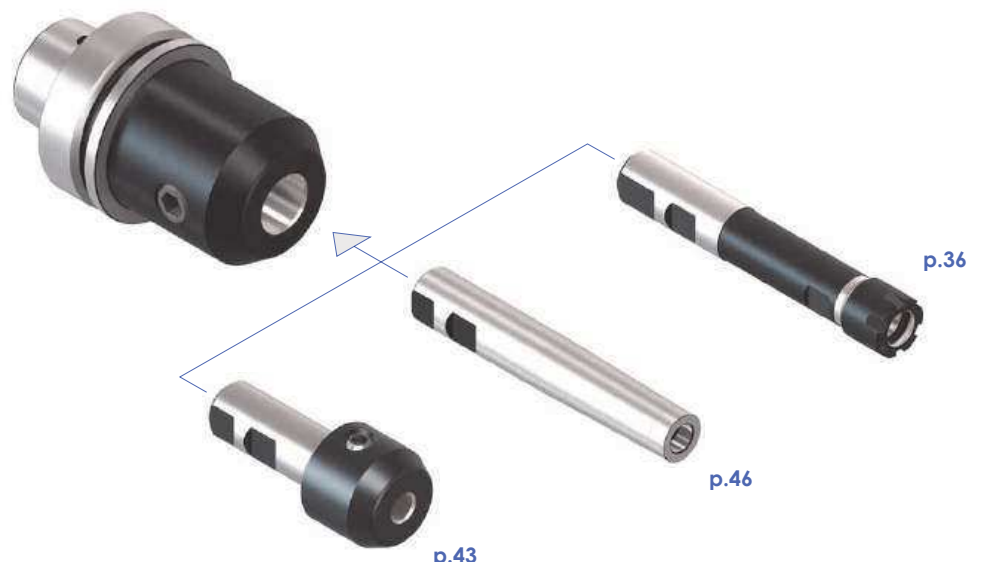

**HSK
F****BARRE A STELO TENERO**
BLANK BARS**HSK**

TIPO	Art.	D	H
HSK 50 F - D. 63 ST	6786	63	200
HSK 63 F - D. 63 ST	6787	63	200

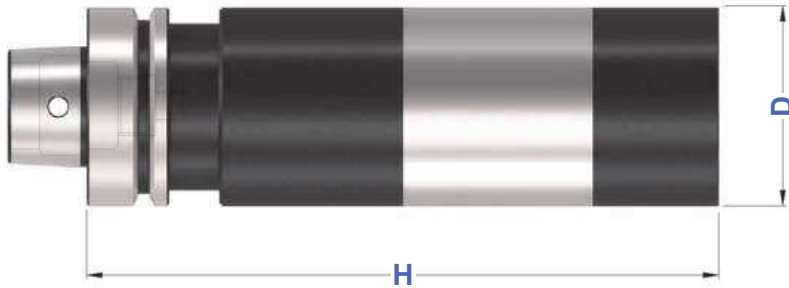
**HSK
F****BARRE DI CONTROLLO**
TEST ARBORS

TIPO	Art.	H	D
HSK 63 F - D. 40 SC	6789	380	40

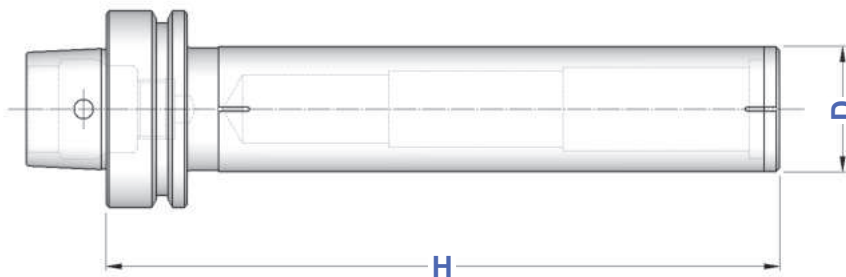
**Dati costruttivi**

- Costruite in acciaio da cementazione certificato
- Cementate con profondità 0,6 - 0,8 mm
- Temprate, rinvenute, brunate
- Durezza HRC 58 ± 2, resistenza 800-1000 N/mm²
- Rotondità in rotazione 0,005
- Cilindricità 0,003

Constructive Features

- Manufactured with hardening steel
- Hardened 0,6 - 0,8 mm depth
- Hardened, tempered, burnished
- Hardness HRC 58 ± 2, strength 800-1000 N/mm²
- Runout accuracy 0,005
- Cylindricity 0,003

**Fornite con
apposito contenitore***Supplied with
suitable case*

HSK F

RIDUZIONI A CONO MORSE PER PUNTE

MT ADAPTERS FOR TWIST DRILLS

Balanced G 6,3

8.000 rpm



TIPO	Art.	CM	H	E
HSK 50 F - CM 1 PUNTE	6290	1	100	25
HSK 50 F - CM 2 PUNTE	6291	2	120	32
HSK 50 F - CM 3 PUNTE	6292	3	140	40
HSK 63 F - CM 1 PUNTE	6293	1	100	25
HSK 63 F - CM 2 PUNTE	6294	2	120	32
HSK 63 F - CM 3 PUNTE	6295	3	140	40
HSK 63 F - CM 4 PUNTE	6296	4	165	48

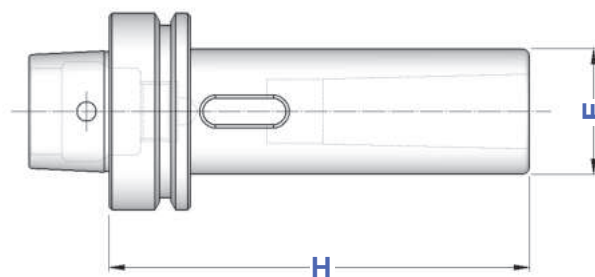

HSK F



RIDUZIONI A CONO MORSE PER FRESE

MT ADAPTERS FOR MILLING CUTTERS

Balanced G 6,3

8.000 rpm



TIPO	Art.	CM	H	E		
HSK 50 F - CM 1 FRESE	6433	1	100	25	7420	4568
HSK 50 F - CM 2 FRESE	6434	2	120	32	7422	4569
HSK 50 F - CM 3 FRESE	6435	3	140	40	7423	4570
HSK 63 F - CM 1 FRESE	6436	1	100	25	7420	4568
HSK 63 F - CM 2 FRESE	6437	2	120	32	7422	4569
HSK 63 F - CM 3 FRESE	6438	3	140	40	7423	4570
HSK 63 F - CM 4 FRESE	6439	4	160	48	7424	4571

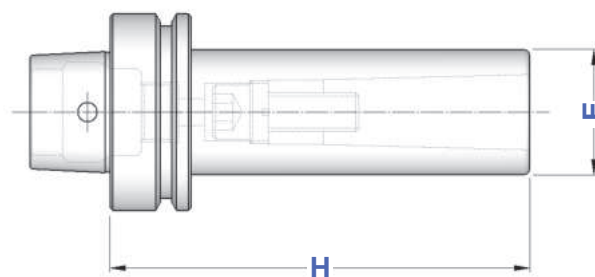



HSK F

PORTAFRESE FISSI FACE MILL HOLDERS

Balanced G 2,5
20.000 rpm



TIPO	Art.	D	L	E		
HSK 50 F - D. 16 FISSO/ H 50	6267	16	17	38	4985	4562
HSK 50 F - D. 22 FISSO/ H 50	6268	22	19	48	4986	4563
HSK 50 F - D. 27 FISSO/ H 60	6269	27	21	58	4987	4564
HSK 50 F - D. 32 FISSO/ H 60	6501	32	24	66	4988	4565
HSK 63 F - D. 16 FISSO/ H 50	6270	16	17	38	4985	4562
HSK 63 F - D. 16 FISSO/ H 100	6503					
HSK 63 F - D. 22 FISSO/ H 50	6271	22	19	48	4986	4563
HSK 63 F - D. 22 FISSO/ H 100	6504					
HSK 63 F - D. 27 FISSO/ H 60	6272	27	21	58	4987	4564
HSK 63 F - D. 27 FISSO/ H 100	6505					
HSK 63 F - D. 32 FISSO/ H 60	6273	32	24	63	4988	4565
HSK 63 F - D. 32 FISSO/ H 100	6506			66		
HSK 63 F - D. 40 FISSO/ H 60	6274	40	27	80	4989	4566
HSK 63 F - D. 40 FISSO/ H 100	6507					

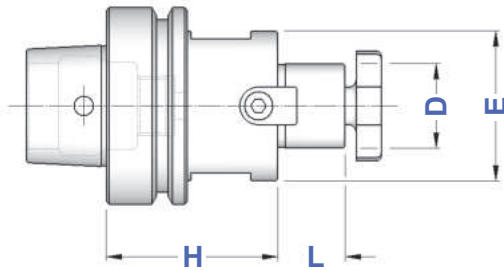



HSK F

PORTAFRESE COMBINATI DIN 6358 COMBI SHELL MILL HOLDERS

Balanced G 6,3
8.000 rpm



TIPO	Art.	D	L1	L	E			
HSK 63 F - D. 16 C / H 60	6398	16	27	17	32	4090	4985	4562
HSK 63 F - D. 22 C / H 60	6399	22	31	19	40	4091	4986	4563
HSK 63 F - D. 27 C / H 60	6400	27	33	21	48	4092	4987	4564
HSK 63 F - D. 32 C / H 60	6401	32	38	24	58	4093	4988	4565
HSK 63 F - D. 40 C / H 70	6402	40	41	27	70	4094	4989	4566

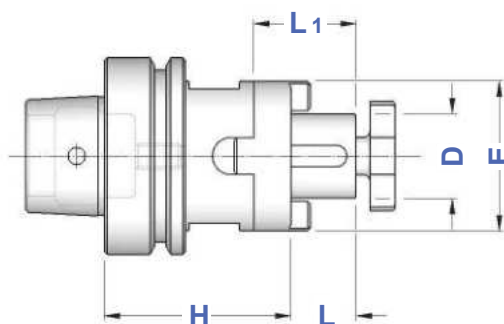

HSK F

MANDRINI PER FRESE CON ATTACCO FILETTATO CHUCKS FOR MILLING CUTTERS WITH THREADED SHANK

Balanced G 2,5
20.000 rpm



TIPO	Art.	M	D1	D2	D3	H	L
HSK 63 F - M 6 / H 59	6871	M 6	6,5	10	10	59	33
HSK 63 F - M 6 / H 84	6872				20	84	58
HSK 63 F - M 6 / H 109	6873				23	109	83
HSK 63 F - M 8 / H 59	6874	M 8	8,5	13	15	59	33
HSK 63 F - M 8 / H 84	6875				23	84	58
HSK 63 F - M 8 / H 109	6876				23	109	83
HSK 63 F - M 8 / H 134	6877				26	134	108
HSK 63 F - M 10 / H 59	6878	M 10	10,5	18	19,5	59	33
HSK 63 F - M 10 / H 84	6879				23	84	58
HSK 63 F - M 10 / H 109	6880				28	109	83
HSK 63 F - M 10 / H 134	6881				32	134	108
HSK 63 F - M 12 / H 59	6882	M 12	12,5	21	24	59	33
HSK 63 F - M 12 / H 84	6883				24	84	58
HSK 63 F - M 12 / H 109	6884				31	109	83
HSK 63 F - M 12 / H 134	6885				33	134	108
HSK 63 F - M 16 / H 59	6886	M 16	17,0	29	34	59	33
HSK 63 F - M 16 / H 84	6887				34	84	58
HSK 63 F - M 16 / H 109	6888				34	109	83
HSK 63 F - M 16 / H 134	6889				36	134	108

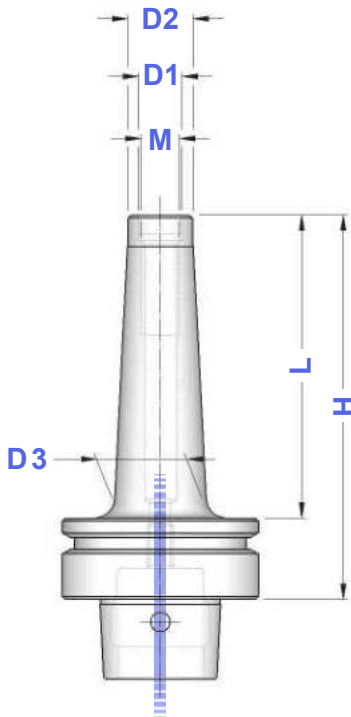

Adduttori per refrigerante
Coolant tubes
p.189

Prolunghe, Riduzioni, Portapinze ER con attacco filettato a pag. 46

Extensions, Reductions, ER Collet Chucks with threaded shank at page 46



CARATTERISTICHE TECNICHE ATTACCO POLIGONALE (DIN ISO 26623-1)

POLYGONAL SHANK (DIN ISO 26623-1) STANDARD FEATURES

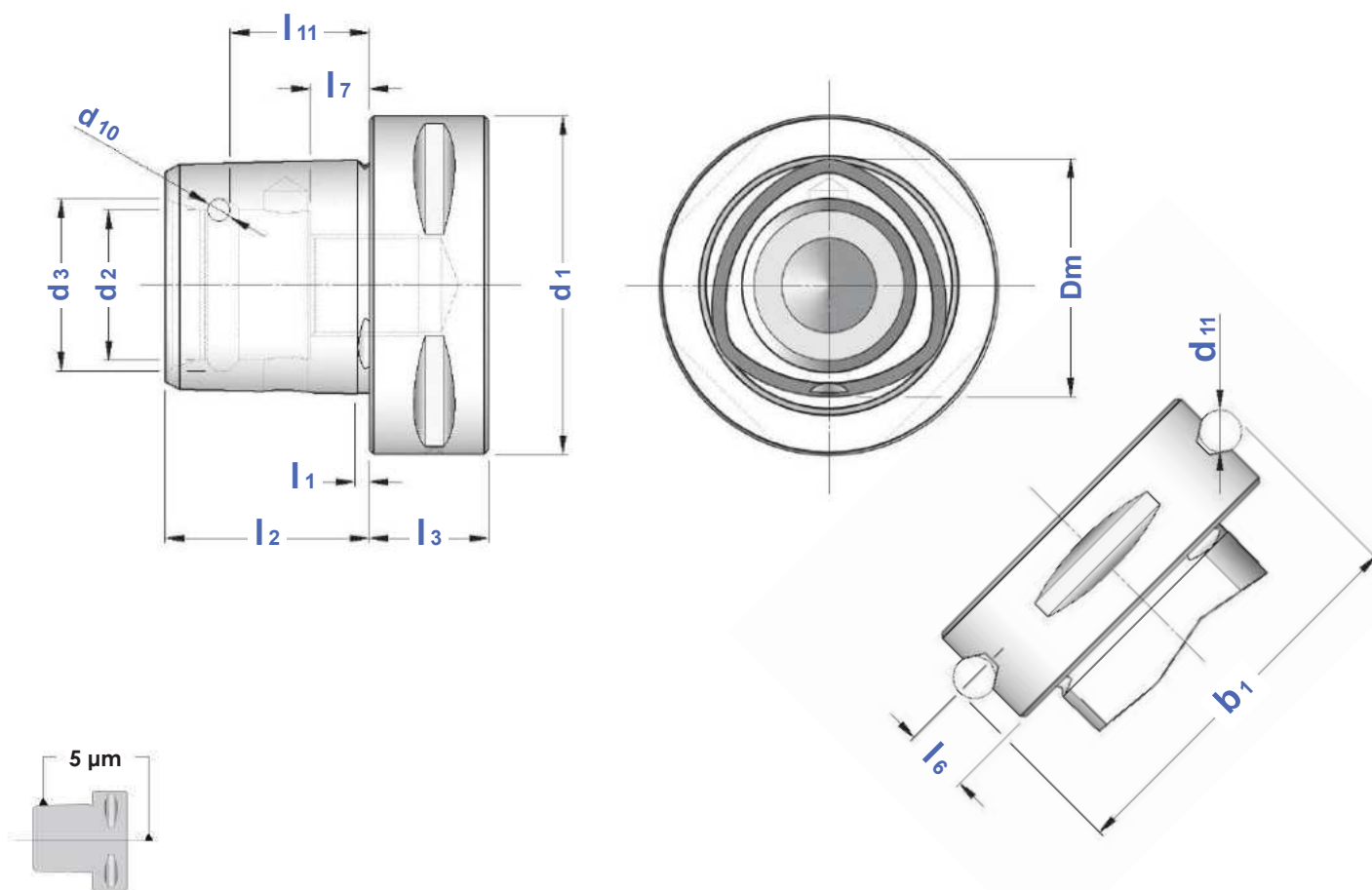

POLYGONAL	b1	d1	d2	d3	d10	d11	Dm	l1	l2	l3	l6	l7	l11
C 32	39	32	15	16,5	1,5	5	22	2,5	19	15	6	6	13,5
C 40	46	40	18	20	2	5	28	2,5	24	20	8	9	17,5
C 50	59,3	50	21	24	3	7	35	3	30	20	10	10	22
C 63	70,7	63	28	32	4	7	44	3	38	22	12	11	26
C 80	86	80	32	38	6	7	55	3	48	30	12	20	34

RACCORDI PER LUBROREFRIGERANTE
COOLANT TUBES

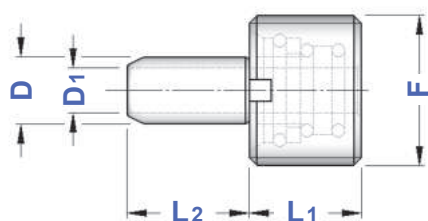

Art.	POLYGONAL	F	D	D1	L1	L2	
11696	C 50	M 16 x 1,5	7	5	14	14,4	11596
11697	C 63	M 20 x 2	8	6	15	15,7	11597

INDICE DELL' ATTACCO POLIGONALE (DIN ISO 26623-1)

INDEX OF POLYGONAL SHANK (DIN ISO 26623 -1)

**PORTAPINZA ER
ghiera MINI**ER MINI NUT
COLLET CHUCKS
pag. 200**PORTAPINZA ER
ghiera ESAGONALE**ER HEXAGONAL NUT
COLLET CHUCKS
pag. 200**PORTAPINZA ER
ghiera STANDARD**ER STANDARD NUT
COLLET CHUCKS
pag. 201**AUTOSERRANTI INTEGRALI**MONOLITHIC DRILL CHUCKS
pag. 202**FORTE SERRAGGIO**HIGH GRIP CHUCKS
pag. 202**BARRE a STELO TENERO**BLANK BARS
pag. 203**BARRE di CONTROLLO**TEST ARBORS
pag. 203**PORTA PUNTE ad INSERTI**INDEXABLE DRILL HOLDERS
pag. 204**riduzioni a CONO MORSE
per PUNTE**MT ADAPTERS for Twist Drills
pag. 204**PORTAFRESE WELDON**END MILL HOLDERS
for DIN 1835-B SHANK
pag. 205**PORTAFRESE FISSI**FACE MILL HOLDERS
pag. 206**PORTA FRESE con
ATTACCO FILETTATO**THREADED SHANK
MILLING CUTTERS HOLDERS
pag. 207**MASCHIATORI
DOPPIA COMPENSAZIONE**DOUBLE COMPENSATION
TAPPING CHUCKS
pag. 207**riduzioni da POLIGONALE
a POLIGONALE**POLYGONAL to POLYGONAL
REDUCTIONS
pag. 208**prolunghe POLIGONALI**POLYGONAL EXTENSIONS
pag. 208**adattatori da STELO
CILINDRICO a POLIGONALE**CYLINDRICAL SHANK ADAPTERS
to POLYGONAL
pag. 209

➔ segue
continue

**PORTAUTENSILE
ASSIALE DESTRO**
RIGHT HAND AXIAL
TOOLHOLDER
pag. 210



**ASSIALE DESTRO
RIBALTABILE SINISTRO**
RIGHT HAND AXIAL TOOLHOLDER
OVERTURNABLE LEFT HAND
pag. 211



**PORTAUTENSILE ASSIALE
TRIPLO DESTRO**
TRIPLE RIGHT HAND
AXIAL TOOLHOLDER
pag. 212



PORTABARENI
BORING BAR HOLDERS
pag. 213



**PORTAUTENSILE α 45°
DESTRO**
45° RIGHT HAND
TOOLHOLDER
pag. 214



**α 45° SINISTRO
RIBALTABILE DESTRO**
LEFT HAND 45° TOOLHOLDER
OVERTURNABLE RIGHT HAND
pag. 215



**PORTALAMA
DESTRO**
RIGHT AXIAL TOOLHOLDERS
for CUT OFF TOOLS
pag. 216



**SMONTACONI
ORIENTABILI**
ORIENTABLE
TIGHTENING FIXTURES
pag. 241



**PORTAUTENSILE
ASSIALE SINISTRO**
LEFT HAND AXIAL
TOOLHOLDER
pag. 210



**PORTAUTENSILE
ASSIALE α 2 SEDI**
AXIAL TOOLHOLDER
with 2 SEATS
pag. 211



**PORTAUTENSILE ASSIALE
TRIPLO SINISTRO**
TRIPLE LEFT HAND
AXIAL TOOLHOLDER
pag. 212



TAPPI di PROTEZIONE
BLANKING PLUGS
pag. 213



**PORTAUTENSILE α 45°
SINISTRO**
45° LEFT HAND
TOOLHOLDER
pag. 214



**RADIALE DESTRO
RIBALTABILE SINISTRO**
RIGHT HAND RADIAL TOOLHOLDER
OVERTURNABLE LEFT HAND
pag. 215



**PORTALAMA
SINISTRO**
LEFT AXIAL TOOLHOLDERS
for CUT OFF TOOLS
pag. 216



MAGAZZINI PORTACONI
TOOL STORES
pag. 244 - 245



POLYGONAL

DIN ISO 26623-1

PORTAPINZA ER - GHIERA MINI

ER COLLET CHUCKS with MINI NUT



Balanced G 6,3
8.000 rpm

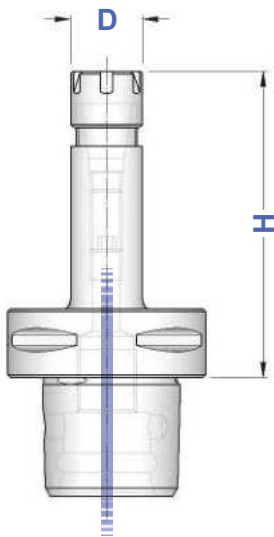
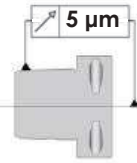

TIPO	Art.	D	RANGE			
C 40 - ER 11 GM/H 60	11060	16	ER 11 1÷8	0432	5718	5573
C 40 - ER 16 GM/H 60	11061	22	ER 16 1÷12	1229	5719	0364
C 40 - ER 20 GM/H 60	11062	28	ER 20 1÷15	1230	5720	0787
C 40 - ER 25 GM/H 60	11063	35	ER 25 1÷20	1231	5721	0996
C 50 - ER 11 GM/H 60	11064	16	ER 11 1÷8	0432	5718	5573
C 50 - ER 11 GM/H 100	11065					
C 50 - ER 11 GM/H 160	11066					
C 50 - ER 16 GM/H 60	11067	22	ER 16 1÷12	1229	5719	0364
C 50 - ER 16 GM/H 100	11068					
C 50 - ER 16 GM/H 160	11069					
C 50 - ER 20 GM/H 60	11070	28	ER 20 1÷15	1230	5720	0787
C 50 - ER 20 GM/H 100	11071					
C 50 - ER 20 GM/H 160	11072					
C 50 - ER 25 GM/H 60	11073	35	ER 25 1÷20	1231	5721	0996
C 50 - ER 25 GM/H 100	11074					
C 50 - ER 25 GM/H 160	11075					
C 63 - ER 11 GM/H 60	11076	16	ER 11 1÷8	1231	5721	0996
C 63 - ER 11 GM/H 100	11077					
C 63 - ER 11 GM/H 160	11078					
C 63 - ER 16 GM/H 60	11079	22	ER 16 1÷12	1229	5719	0364
C 63 - ER 16 GM/H 100	11080					
C 63 - ER 16 GM/H 160	11081					
C 63 - ER 20 GM/H 60	11082	28	ER 20 1÷15	1230	5720	0787
C 63 - ER 20 GM/H 100	11083					
C 63 - ER 20 GM/H 160	11084					
C 63 - ER 25 GM/H 60	11085	35	ER 25 1÷20	1231	5721	0996
C 63 - ER 25 GM/H 100	11086					
C 63 - ER 25 GM/H 160	11087					



POLYGONAL

DIN ISO 26623-1

PORTAPINZA ER - GHIERA ESAGONALE

ER COLLET CHUCKS with HEXAGONAL NUT



Balanced G 6,3
8.000 rpm

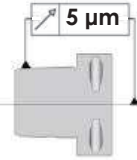

TIPO	Art.	D	RANGE			
C 40 - ER 16 GE / H 70	11090	28	ER 16 1÷12	1214	2906	0364
C 40 - ER 20 GE / H 52	11091	34	ER 20 1÷15	1215	2907	0787
C 50 - ER 16 GE / H 60	11092	28	ER 16 1÷12	1214	2906	0364
C 50 - ER 16 GE / H 100	11093					
C 50 - ER 20 GE / H 60	11094	34	ER 20 1÷15	1215	2907	0787
C 50 - ER 20 GE / H 100	11095					
C 63 - ER 16 GE / H 60	11096	28	ER 16 1÷12	1214	2906	0364
C 63 - ER 16 GE / H 100	11097					
C 63 - ER 20 GE / H 60	11098	34	ER 20 1÷15	1215	2907	0787
C 63 - ER 20 GE / H 100	11099					



POLYGONAL

DIN ISO 26623-1

PORTAPINZA ER - GHIERA STANDARD

ER COLLET CHUCKS with STANDARD NUT



Balanced G 6,3
8.000 rpm

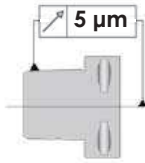

TIPO	Art.	D	RANGE			
C 40 - ER 16/H 70	11200	32	ER 16 1÷12	4993	3698	0364
C 40 - ER 20/H 52	11201	35	ER 20 1÷15	4994	3699	0787
C 40 - ER 25/H 52	11202	42	ER 25 1÷20	4995	3669	0996
C 40 - ER 32/H 54	11203	50	ER 32 2÷25	4996	3670	0988
C 50 - ER 16/H 60	11204	32	ER 16 1÷12	4993	3698	0364
C 50 - ER 16/H 100	11205					
C 50 - ER 20/H 60	11206	35	ER 20 1÷15	4994	3699	0787
C 50 - ER 20/H 100	11207					
C 50 - ER 25/H 60	11208	42	ER 25 1÷20	4995	3669	0996
C 50 - ER 25/H 100	11209					
C 50 - ER 32/H 60	11210	50	ER 32 2÷25	4996	3670	0988
C 50 - ER 32/H 100	11211					
C 50 - ER 40/H 65	11212	63	ER 40 3÷32	4997	3671	0821
C 50 - ER 40/H 100	11213					
C 63 - ER 16/H 60	11214	32	ER 16 1÷12	4993	3698	0364
C 63 - ER 16/H 100	11215					
C 63 - ER 20/H 60	11216	35	ER 20 1÷15	4994	3699	0787
C 63 - ER 20/H 100	11217					
C 63 - ER 25/H 60	11218	42	ER 25 1÷20	4995	3669	0996
C 63 - ER 25/H 100	11219					
C 63 - ER 25/H 160	11220					
C 63 - ER 32/H 60	11221	50	ER 32 2÷25	4996	3670	0988
C 63 - ER 32/H 100	11222					
C 63 - ER 32/H 160	11223					
C 63 - ER 40/H 70	11224	63	ER 40 3÷32	4997	3671	0821
C 63 - ER 40/H 100	11225					
C 80 - ER 25/H 70	11226	42	ER 25 1÷20	4995	3669	0996
C 80 - ER 32/H 70	11227	50	ER 32 2÷25	4996	3670	0988
C 80 - ER 40/H 70	11228	63	ER 40 3÷32	4997	3671	0821

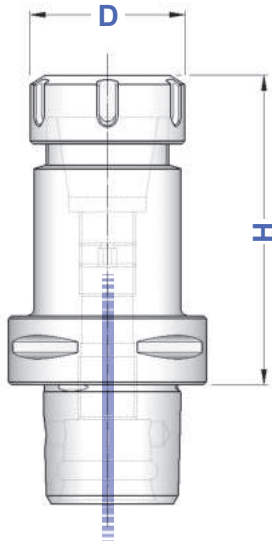

Tamponi pulitori per SEDE pinza ER

Taper cleaner for ER collet SEAT



p.243

POLYGONAL

DIN ISO 26623-1

MANDRINI AUTOSERRANTI INTEGRALI
ROTAZIONE DESTRA E SINISTRA
MONOLITHIC DRILL CHUCKS - RIGHT & LEFT SPIN



Forniti completi dell'apposita chiave
Supplied complete with suitable wrench

TIPO	Art.	RANGE	E	H	
C 40 - DCU 13	11230	0,5 ÷ 13	50	115	2372
C 50 - DCU 13	11231	0,5 ÷ 13	50	98	2372
C 63 - DCU 13	11232	0,5 ÷ 13	50	105	2372
C 63 - DCU 16	11233	3 ÷ 16	50	110	
C 80 - DCU 13	11234	0,5 ÷ 13	50	109	2372
C 80 - DCU 16	11235	3 ÷ 16	50	114	

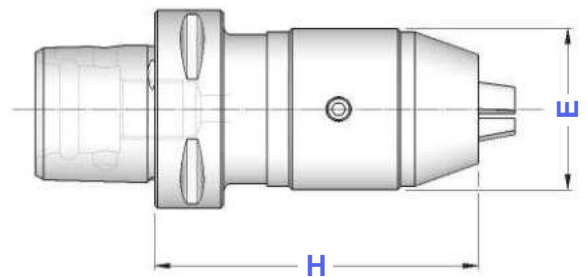

POLYGONAL

DIN ISO 26623-1

MANDRINI A FORTE SERRAGGIO
HIGH GRIP CHUCKS



Forniti completi dell'apposita chiave
Supplied complete with suitable wrench

TIPO	Art.	E	D	
C 40 - PC 12 / H 65	11240	34	12	0804
C 40 - PC 16 / H 65	11241	42	16	0805
C 40 - PC 20 / H 90	11242	50	20	0809
C 50 - PC 12 / H 80	11243	34	12	0804
C 50 - PC 16 / H 70	11244	42	16	0805
C 50 - PC 20 / H 75	11245	54	20	0809
C 50 - PC 32 / H 95	11246	63	32	0810
C 63 - PC 12 / H 100	11247	34	12	0804
C 63 - PC 16 / H 100	11248	42	16	0805
C 63 - PC 20 / H 80	11249	54	20	0809
C 63 - PC 32 / H 100	11250	72	32	0810
C 80 - PC 20 / H 75	11251	50	20	0809
C 80 - PC 32 / H 95	11252	63	32	0810

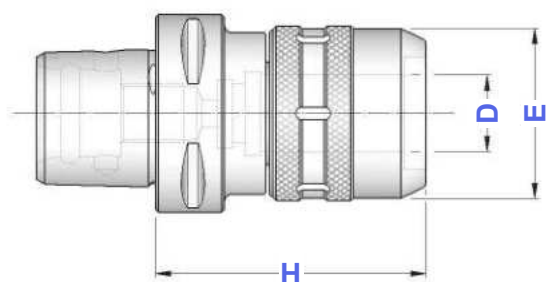

Pinze precisione standard pag. 270
Pinze alta precisione pag. 271

Standard precision collets page 270
High precision collets page 271



POLYGONAL

DIN ISO 26623-1

BARRE A STELO TENERO

BLANK BARS

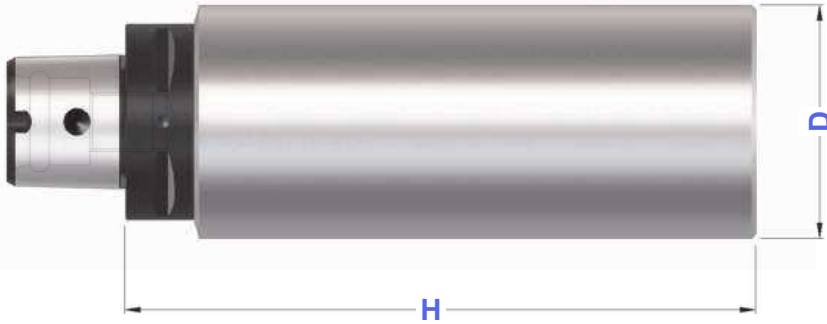

TIPO	Art.	D	H
C 40 - D. 40 x 120 ST	11260	40	120
C 40 - D. 60 x 165 ST	11261	63	165
C 40 - D. 80 x 75 ST	11262	80	75
C 40 - D. 80 x 120 ST	11263	80	120
C 50 - D. 50 x 150 ST	11264	50	150
C 50 - D. 90 x 80 ST	11265	90	80
C 50 - D. 95 x 150 ST	11266	91	150
C 63 - D. 63 x 180 ST	11267	63	180
C 63 - D. 75 x 195 ST	11268	75	195
C 63 - D. 110 x 85 ST	11269	110	85
C 63 - D. 110 x 120 ST	11270	110	120
C 63 - D. 120 x 180 ST	11271	120	180
C 80 - D. 80 x 200 ST	11272	80	200
C 80 - D. 120 x 160 ST	11273	115	160

POLYGONAL

DIN ISO 26623-1

BARRE DI CONTROLLO

TEST ARBORS

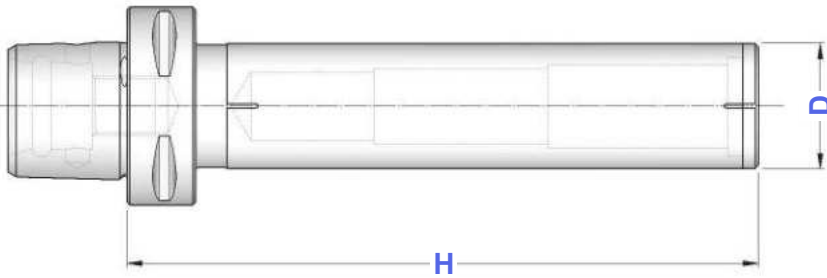

TIPO	Art.	H	D
C 40 - D. 35 x 300 SC	11281	300	35
C 63 - D. 40 x 180 SC	11285	180	40
C 63 - D. 40 x 346 SC	11286	346	40
C 80 - D. 40 x 346 SC	11288	346	40

Dati costruttivi

- Costruite in acciaio da cementazione certificato
- Cementate con profondità 0,6 - 0,8 mm
- Temprate, rinvenute, brunate
- Durezza HRC 58 ± 2, resistenza 800-1000 N/mm²
- Rotondità in rotazione 0,005
- Cilindricità 0,003

Constructive Features

- Manufactured with hardening steel
- Hardened 0,6 - 0,8 mm depth
- Hardened, tempered, burnished
- Hardness HRC 58 ± 2, strength 800-1000 N/mm²
- Runout accuracy 0,005
- Cylindricity 0,003



**Fornite con
apposito contenitore**

Supplied with
suitable case

POLYGONAL

DIN ISO 26623-1

MANDRINI PER PUNTE AD INSERTI

INDEXABLE DRILL HOLDERS



Balanced G 6,3
8.000 rpm



TIPO	Art.	D	H	E	L	
C 40 - D. 8 P	11300	8	50	28	35	4970
C 40 - D. 10 P	11301	10	50	35	35	4971
C 40 - D. 12 P	11302	12	50	42	36	4972
C 40 - D. 16 P	11303	16	56	36	54	0403
C 40 - D. 20 P	11304	20	60	40	54	0403
C 40 - D. 25 P	11305	25	77	45	59	0417
C 50 - D. 8 P	11306	8	52	44	35	4970
C 50 - D. 10 P	11307	10	52	44	35	4971
C 50 - D. 12 P	11308	12	52	44	36	4972
C 50 - D. 16 P	11309	16	65	44	49	0403
C 50 - D. 20 P	11310	20	60	44	51	0403
C 50 - D. 25 P	11311	25	70	44	59	0417
C 50 - D. 32 P	11312	32	75	52	63	0417
C 63 - D. 8 P	11313	8	60	44	36	4970
C 63 - D. 10 P	11314	10	60	44	40	4971
C 63 - D. 12 P	11315	12	60	44	44	4972
C 63 - D. 16 P	11316	16	70	36	52	0403
C 63 - D. 20 P	11317	20	70	40	54	0403
C 63 - D. 25 P	11318	25	72	45	59	0417
C 63 - D. 32 P	11319	32	75	52	63	0417
C 63 - D. 40 P	11320	40	85	63	73	0493
C 80 - D. 16 P	11321	16	80	36	54	0403
C 80 - D. 20 P	11322	20	80	40	54	0403
C 80 - D. 25 P	11323	25	85	45	59	0417
C 80 - D. 32 P	11324	32	90	52	63	0417
C 80 - D. 40 P	11325	40	95	63	73	0493

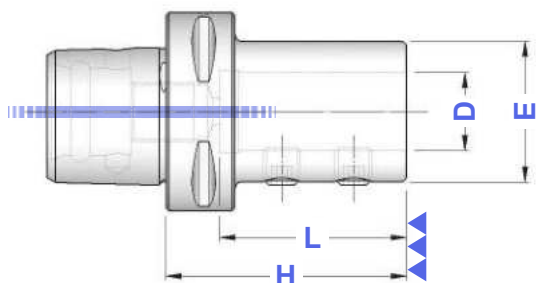

POLYGONAL

DIN ISO 26623-1

RIDUZIONI A CONO MORSE PER PUNTE

MT ADAPTERS FOR TWIST DRILLS

Balanced G 6,3
8.000 rpm



TIPO	Art.	CM	H	E
C 40 - CM 2 PUNTE	11400	2	110	32
C 40 - CM 3 PUNTE	11401	3	130	40
C 50 - CM 2 PUNTE	11402	2	110	32
C 50 - CM 3 PUNTE	11403	3	130	40
C 63 - CM 2 PUNTE	11404	2	110	32
C 63 - CM 3 PUNTE	11405	3	130	40
C 63 - CM 4 PUNTE	11406	4	150	48
C 80 - CM 3 PUNTE	11407	3	140	40
C 80 - CM 4 PUNTE	11408	4	170	52
C 80 - CM 5 PUNTE	11409	5	200	63

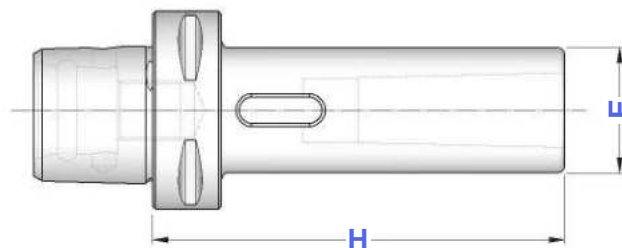

POLYGONAL

DIN ISO 26623-1

PORTAFRESE WELDON

END MILL HOLDERS FOR DIN 1835-B SHANKS



Balanced G 6,3
8.000 rpm



WE6 ÷ WE20
1 grano
1 screw



WE25 ÷ WE40
2 grani
2 screws

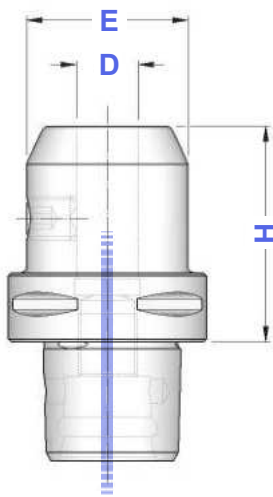

TIPO	Art.	D	H	E	
C 40 - WE 6/H 50	11350	6	50	25	4970
C 40 - WE 8/H 50	11351	8	50	28	4971
C 40 - WE 10/H 50	11352	10	50	35	4972
C 40 - WE 12/H 55	11353	12	55	42	4973
C 40 - WE 16/H 55	11355	16	55	48	4974
C 50 - WE 6/H 55	11356	6	55	25	4970
C 50 - WE 8/H 55	11357	8	55	28	4971
C 50 - WE 10/H 65	11358	10	65	35	4972
C 50 - WE 12/H 65	11359	12	65	42	4973
C 50 - WE 16/H 65	11361	16	65	48	4974
C 50 - WE 20/H 65	11363	20	65	52	4975
C 50 - WE 25/H 80	11364	25	80	63	4976
C 63 - WE 6/H 55	11365	6	55	25	4970
C 63 - WE 8/H 55	11366	8	55	28	4971
C 63 - WE 10/H 60	11367	10	60	35	4972
C 63 - WE 12/H 60	11368	12	60	42	4973
C 63 - WE 16/H 65	11370	16	65	48	4974
C 63 - WE 20/H 65	11371	20	65	52	4975
C 63 - WE 25/H 80	11372	25	80	63	4976
C 63 - WE 32/H 90	11373	32	90	72	4977
C 80 - WE 6/H 70	11375	6	70	25	4970
C 80 - WE 8/H 70	11376	8	70	28	4971
C 80 - WE 10/H 70	11377	10	70	35	4972
C 80 - WE 12/H 70	11378	12	70	42	4973
C 80 - WE 16/H 70	11380	16	70	48	4974
C 80 - WE 20/H 70	11381	20	70	50	4975
C 80 - WE 25/H 80	11382	25	80	52	4976
C 80 - WE 32/H 80	11383	32	80	72	4977
C 80 - WE 40/H 110	11384	40	110	80	4977

Accessori per Portafrese Weldon
Accessories for End Mill Holders



POLYGONAL

DIN ISO 26623-1

PORTAFRESE FISSI

FACE MILL HOLDERS

Balanced G 6,3

8.000 rpm

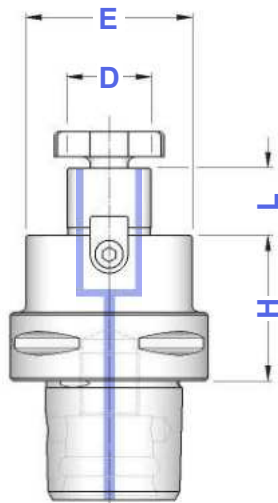

con passaggio
REFRIGERANTE
COOLANT THROUGH

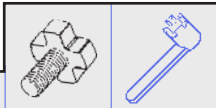

TIPO	Art.	D	L	E		
C 40 - D. 16 FISSO/ H 32	11450	16	17	32	4985	4562
C 40 - D. 16 FISSO/ H 55	11451			38		
C 40 - D. 22 FISSO/ H 25	11452	22	19	40	4986	4563
C 40 - D. 22 FISSO/ H 55	11453			48		
C 50 - D. 16 FISSO/ H 35	11454	16	17	38	4985	4562
C 50 - D. 16 FISSO/ H 60	11455			60		
C 50 - D. 22 FISSO/ H 32	11456	22	19	48	4986	4563
C 50 - D. 22 FISSO/ H 60	11457			60		
C 50 - D. 27 FISSO/ H 60	11458	27	21	58	4987	4564
C 50 - D. 32 FISSO/ H 60	11459	32	24	63	4988	4565
C 63 - D. 16 FISSO/ H 40	11460	16	17	32	4985	4562
C 63 - D. 16 FISSO/ H 63	11461			38		
C 63 - D. 22 FISSO/ H 25	11462	22	19	55	4986	4563
C 63 - D. 22 FISSO/ H 100	11463			48		
C 63 - D. 27 FISSO/ H 25	11464	27	21	63	4987	4564
C 63 - D. 27 FISSO/ H 100	11465			58		
C 63 - D. 32 FISSO/ H 25	11466	32	24	63	4988	4565
C 63 - D. 32 FISSO/ H 100	11467			63		
C 63 - D. 40 FISSO/ H 40	11468	40	27	89	4989	4566
C 63 - D. 40 FISSO/ H 100	11469			70		
C 80 - D. 16 FISSO/ H 50	11470	16	17	32	4985	4562
C 80 - D. 22 FISSO/ H 30	11471	22	19	80	4986	4563
C 80 - D. 27 FISSO/ H 30	11472	27	21	80	4987	4564
C 80 - D. 32 FISSO/ H 30	11473	32	24	80	4988	4565
C 80 - D. 40 FISSO/ H 30	11474	40	27	80	4989	4566



Aperto
Open



Chiuso
Closed



Smontaconi orientabili a pagina 241
Il bloccaggio del mandrino avviene sulla
flangia mediante la chiusura a morsa
Orientable Tightening Fixture on page 241
The spindle is locked on the flange by
means of vise closure

POLYGONAL

DIN ISO 26623-1

MANDRINI PER FRESE CON ATTACCO FILETTATO

CHUCKS FOR MILLING CUTTERS WITH THREADED SHANK

Balanced G 6,3

8.000 rpm



p.46

TIPO	Art.	M	D1	D2	D3	H	L
C 50 - M 8 / H 70	11420	M 8	8,5	13	20	70	50
C 50 - M 10 / H 80	11421	M 10	10,5	18	25	80	60
C 50 - M 12 / H 80	11422	M 12	12,5	21	24	80	60
C 50 - M 16 / H 80	11423	M 16	17,0	29	34	80	60
C 63 - M 8 / H 70	11424	M 8	8,5	13	20	70	48
C 63 - M 10 / H 90	11425	M 10	10,5	18	28	90	68
C 63 - M 12 / H 100	11426	M 12	12,5	21	33	100	78
C 63 - M 16 / H 100	11427	M 16	17,0	29	41	100	78

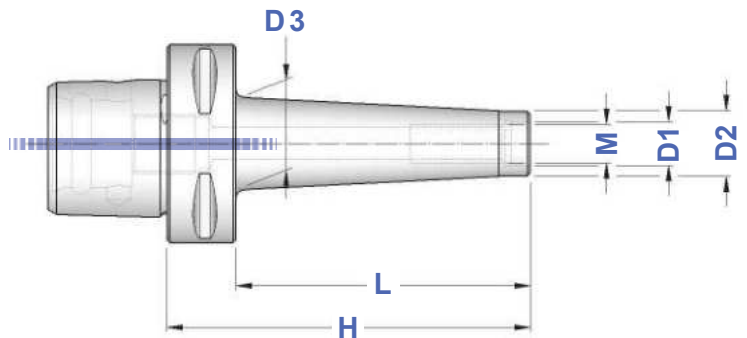

POLYGONAL

DIN ISO 26623-1

MASCHIATORI A CAMBIO RAPIDO CON DOPPIA COMPENSAZIONE

DOUBLE COMPENSATION QUICK CHANGE TAPPING CHUCKS

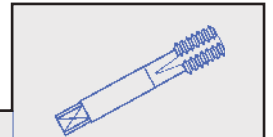

TIPO	Art.	H	E	B	COMPENSAZIONE	
C 40 - B. 1	11550	68	41	19	- 7,5 + 7,5	M 3 ÷ M 12 (*M18)
C 40 - B. 2	11551	91	60	31	- 10,0 + 10,0	M 6 ÷ M 20 (*M30)
C 50 - B. 1	11552	68	41	19	- 7,5 + 7,5	M 3 ÷ M 12 (*M18)
C 50 - B. 2	11553	91	60	31	- 10,0 + 10,0	M 6 ÷ M 20 (*M30)
C 63 - B. 1	11554	73	41	19	- 7,5 + 7,5	M 3 ÷ M 12 (*M18)
C 63 - B. 2	11555	97	60	31	- 10,0 + 10,0	M 6 ÷ M 20 (*M30)
C 63 - B. 3	11556	146	86	48	- 17,5 + 17,5	M 14 ÷ M 33 (*M48)
C 80 - B. 1	11557	75	41	19	- 7,5 + 7,5	M 3 ÷ M 12 (*M18)
C 80 - B. 2	11558	93,5	60	31	- 10,0 + 10,0	M 6 ÷ M 20 (*M30)
C 80 - B. 3	11559	137	86	48	- 17,5 + 17,5	M 14 ÷ M 33 (*M48)

* Bussole con GRANI
Adapters with SCREWS

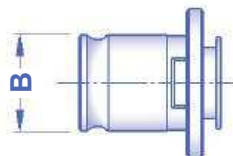
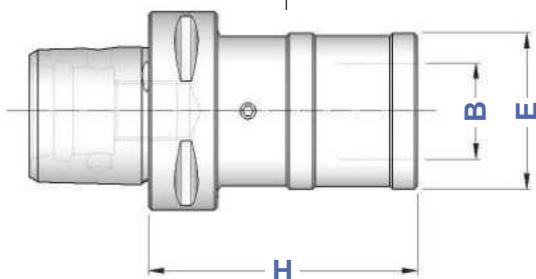
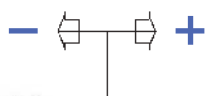



Bussole a maschiare da pag. 235
Tapping Adapters from page 235

POLYGONAL

DIN ISO 26623-1

RIDUZIONI DA POLIGONALE A POLIGONALE

POLYGONAL TO POLYGONAL REDUCTIONS



TIPO	Art.	H	E
C 50 - C 40/ H 65	11500	65	40
C 50 - C 40/ H 85	11501	85	40
C 63 - C 40/ H 80	11502	80	40
C 63 - C 50/ H 80	11503	80	50
C 80 - C 50/ H 120	11504	120	50
C 80 - C 63/ H 110	11505	110	63

POLIGONALE ⇨ POLIGONALE
(ISO 26623-1 ⇨ ISO 26623-1)

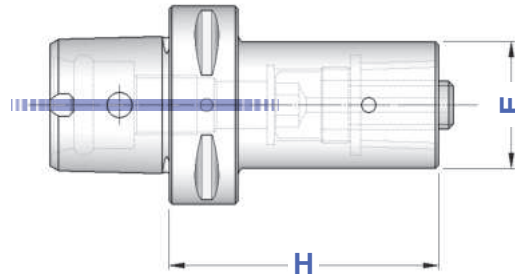

DIN 69871 ⇨ POLIGONALE



p.126

BT ⇨ POLIGONALE



p.154

HSK A+C ⇨ POLIGONALE



p.174

POLYGONAL

DIN ISO 26623-1

PROLUNGHE DA POLIGONALE A POLIGONALE

POLYGONAL TO POLYGONAL EXTENTIONS



TIPO	Art.	H	E
C 40 - C 40/ H 40	11520	40	40
C 40 - C 40/ H 60	11521	60	40
C 40 - C 40/ H 80	11522	80	40
C 50 - C 50/ H 50	11523	50	50
C 50 - C 50/ H 80	11524	80	50
C 50 - C 50/ H 100	11525	100	50
C 63 - C 63/ H 60	11526	60	63
C 63 - C 63/ H 100	11527	100	63
C 63 - C 63/ H 140	11528	140	63
C 80 - C 80/ H 65	11529	65	80
C 80 - C 80/ H 100	11530	100	80
C 80 - C 80/ H 125	11531	125	80

POLIGONALE ⇨ POLIGONALE
(ISO 26623-1 ⇨ ISO 26623-1)

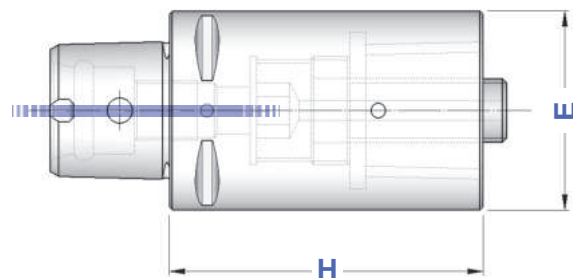

POLYGONAL

DIN ISO 26623-1

ADATTATORI DA STELO CILINDRICO A POLIGONALE

CYLINDRICAL SHANK ADAPTERS TO POLYGONAL SHANK



TIPO	Art.	L	H	d	H1	E	F
d 40 - C 40 / L 100	11585	100	20	40	26	51,5	1/8 G
d 50 - C 50 / L 80	11586	80	24	50	33	61,5	1/8 G
d 50 - C 50 / L 120	11587	120	24	50	33	61,5	1/8 G

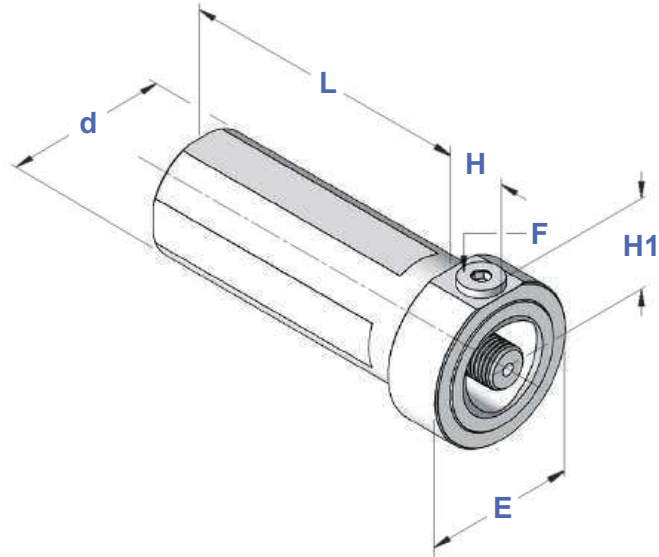

CILINDRICO ⇔ POLIGONALE
(DIN 1835 ⇔ ISO 26623-1)

POLYGONAL

DIN ISO 26623-1

ADATTATORI DA STELO QUADRO A POLIGONALE

SQUARE SHANK ADAPTERS TO POLYGONAL SHANK



DESTRO
RIGHT



SINISTRO
LEFT

TIPO		Art.	L	L1	L2	H	F
DESTRO RIGHT	Q 50 R - C 40	11591	125	100	31	50	1/8 G
	Q 64 R - C 50	11592	145	118	36	64	1/8 G
SINISTRO LEFT	Q 50 L - C 40	11593	125	100	31	50	1/8 G
	Q 64 L - C 50	11594	145	118	36	64	1/8 G

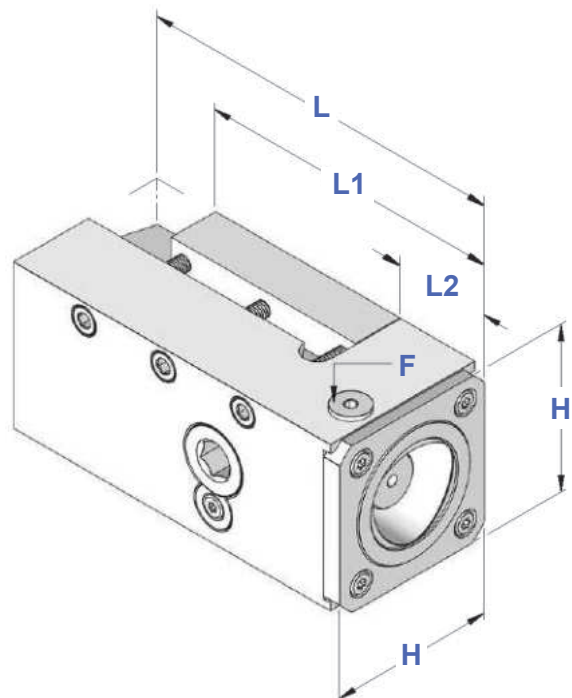

POLYGONAL

DIN ISO 26623-1

PORTAUTENSILE ASSIALE DESTRO

RIGHT HAND AXIAL TOOLHOLDER

TIPO	Art.	d1	h	L
C 63 - A20R	11601	63	20	100
C 63 - A25R	11602	63	25	130
C 63 - A32R	11603	63	32	134

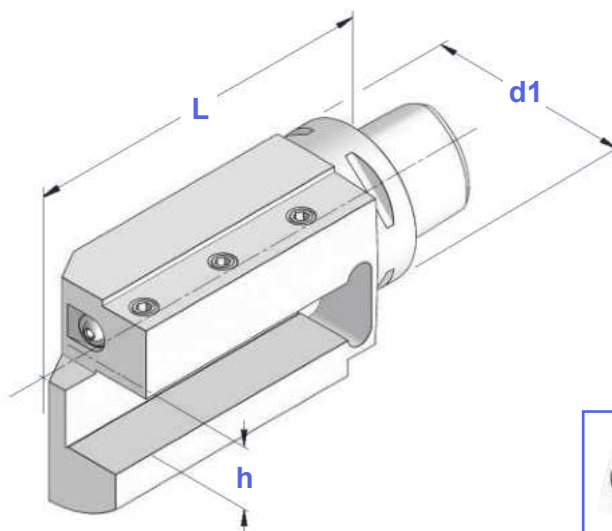

POLYGONAL

DIN ISO 26623-1

PORTAUTENSILE ASSIALE SINISTRO

LEFT HAND AXIAL TOOLHOLDER

TIPO	Art.	d1	h	L
C 63 - A20L	11606	63	20	100
C 63 - A25L	11607	63	25	130
C 63 - A32L	11608	63	32	134

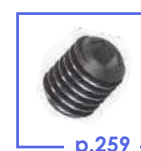
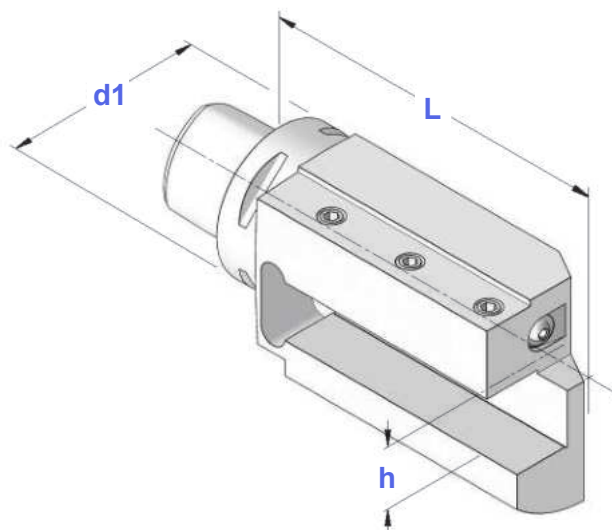

POLYGONAL

DIN ISO 26623-1

PORTAUTENSILE ASSIALE DESTRO - RIBALTABILE SINISTRO

RIGHT HAND AXIAL TOOLHOLDER - OVERTURNABLE LEFT HAND

TIPO	Art.	d1	b1	b2	h	h1	L
C 63 - A25RL	11610	63	58	32	25	45	83

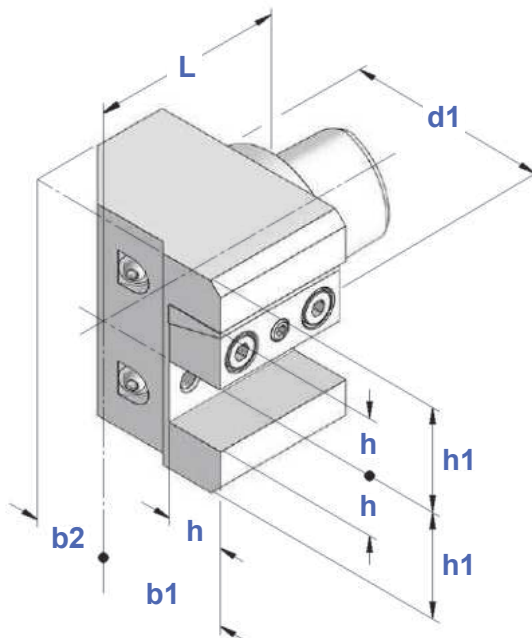

POLYGONAL

DIN ISO 26623-1

PORTAUTENSILE ASSIALE A 2 SEDI

AXIAL TOOLHOLDER WITH 2 SEATS

TIPO	Art.	d1	b1	b2	h	h1	L
C 63 - 2A25/32	11615	63	40	15	25/32	26,5	110

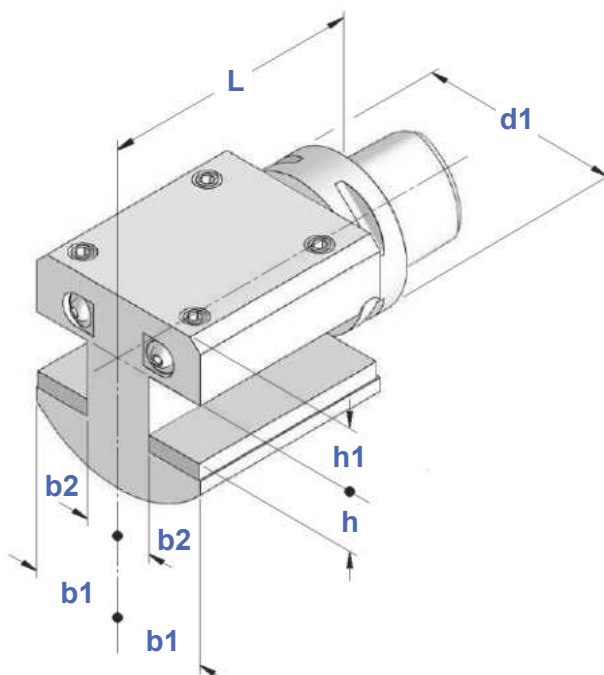

POLYGONAL

DIN ISO 26623-1

PORTAUTENSILE ASSIALE TRIPLO - DESTRO

TRIPLE RIGHT HAND AXIAL TOOLHOLDER

TIPO	Art.	d1	D	b1	b2	h	L
C 63 - AT20R	11620	63	90	36	16	20	110

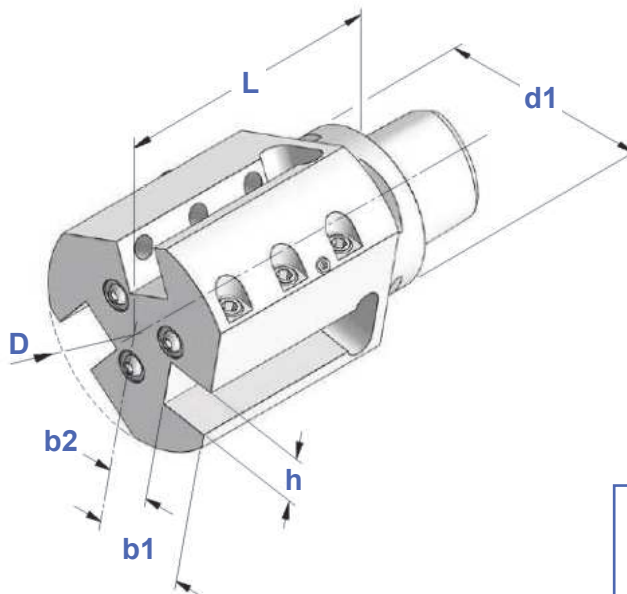

POLYGONAL

DIN ISO 26623-1

PORTAUTENSILE ASSIALE TRIPLO - SINISTRO

TRIPLE LEFT HAND AXIAL TOOLHOLDER

TIPO	Art.	d1	D	b1	b2	h	L
C 63 - AT20L	11625	63	90	36	16	20	110

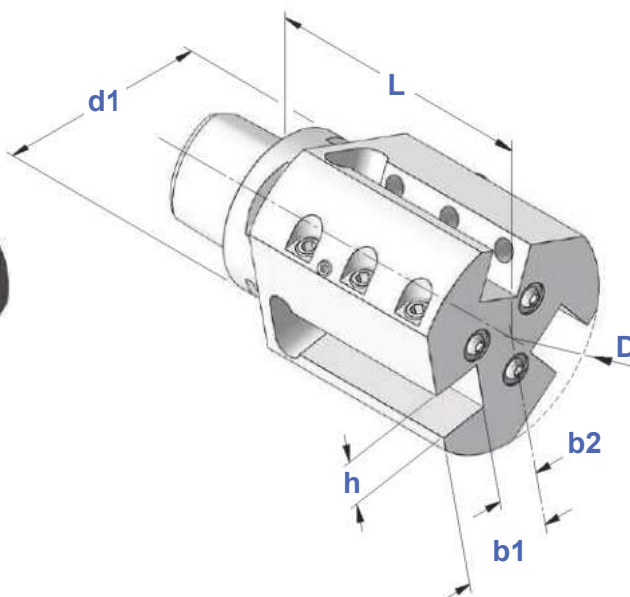

POLYGONAL

DIN ISO 26623-1

PORTABARENI CON REFRIGERAZIONE INTERNA - ESTERNA

BORING BAR HOLDER WITH INSIDE - OUTSIDE COOLING

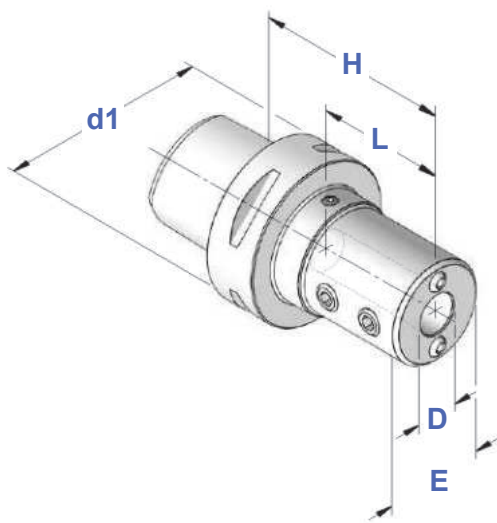

TIPO	Art.	d1	D	E	H	L
C 40 - D.08 PB	11630	40	8	32	60	37
C 40 - D.10 PB	11631	40	10	36	65	40
C 40 - D.12 PB	11632	40	12	36	65	40
C 40 - D.16 PB	11633	40	16	40	70	42
C 40 - D.20 PB	11634	40	20	45	70	42
C 50 - D.08 PB	11635	50	8	32	70	37
C 50 - D.10 PB	11636	50	10	30	70	40
C 50 - D.12 PB	11637	50	12	40	70	40
C 50 - D.16 PB	11638	50	16	45	80	50
C 50 - D.20 PB	11639	50	20	50	80	50
C 50 - D.25 PB	11640	50	25	55	80	50
C 63 - D.08 PB	11641	63	8	32	80	40
C 63 - D.10 PB	11642	63	10	36	80	45
C 63 - D.12 PB	11643	63	12	40	80	45
C 63 - D.16 PB	11644	63	16	45	80	50
C 63 - D.20 PB	11645	63	20	50	80	50
C 63 - D.25 PB	11646	63	25	55	88	57
C 63 - D.32 PB	11647	63	32	72	95	59
C 63 - D.40 PB	11648	63	40	80	105	72
C 80 - D.16 PB	11649	80	16	45	85	48
C 80 - D.20 PB	11650	80	20	50	85	48
C 80 - D.25 PB	11651	80	25	55	85	48
C 80 - D.32 PB	11652	80	32	72	95	58
C 80 - D.40 PB	11653	80	40	80	110	73



TAPPI DI PROTEZIONE POLIGONALI

POLYGONAL BLANKING PLUG



POLIGONALE	Art.
C 40	11690
C 50	11691
C 63	11692
C 80	11693

POLYGONAL

DIN ISO 26623-1

PORTAUTENSILE A 45° DESTRO

45° RIGHT HAND TOOLHOLDER

TIPO	Art.	d1	h	L
C 63 - U25R	11660	63	25	130

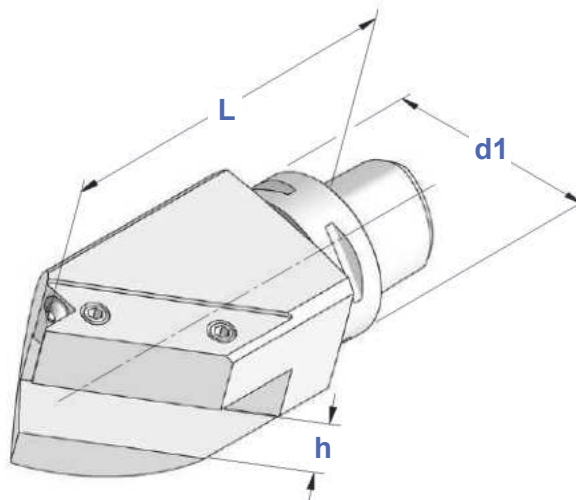

POLYGONAL

DIN ISO 26623-1

PORTAUTENSILE A 45° SINISTRO

45° LEFT HAND TOOLHOLDER

TIPO	Art.	d1	h	L
C 63 - U25L	11665	63	25	130

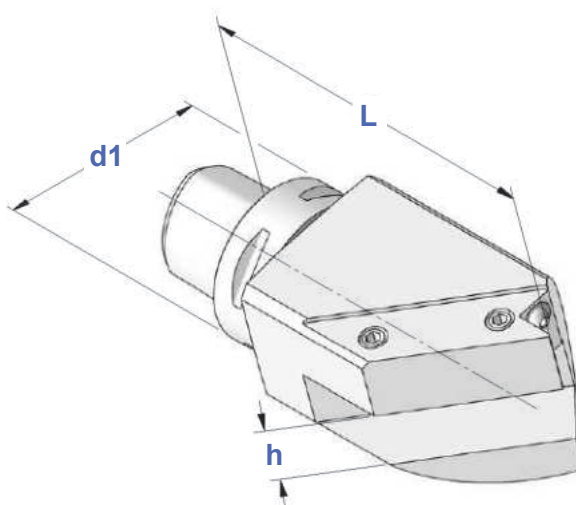

POLYGONAL

DIN ISO 26623-1

PORTAUTENSILE A 45° SINISTRO - RIBALTABILE DESTRO

LEFT HAND 45° TOOLHOLDER - OVERTURNABLE RIGHT HAND

TIPO	Art.	d1	b1	b2	h	h1	L
C 63 - U25LR	11670	63	35	70	25	45	102

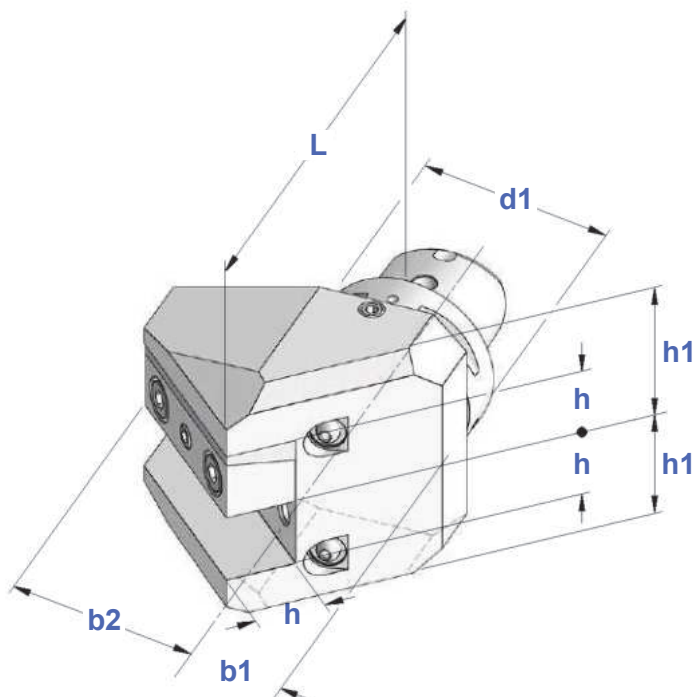

POLYGONAL

DIN ISO 26623-1

PORTAUTENSILE RADIALE DESTRO - RIBALTABILE SINISTRO

RIGHT HAND RADIAL TOOLHOLDER - OVERTURNABLE LEFT HAND

TIPO	Art.	d1	b1	b2	h	h1	L
C 63 - R25RL	11675	63	30	42	25	45	75

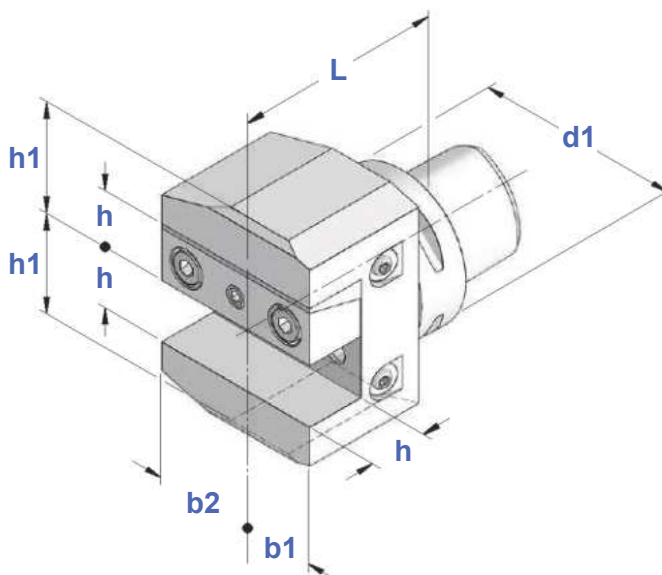

POLYGONAL

DIN ISO 26623-1

PORTALAMA DESTRO

RIGHT AXIAL TOOLHOLDER FOR CUT OFF TOOLS

TIPO	Art.	d1	b1	b2	h	h1	h2	h3	L
C 63 - C32R	11682	63	40	34	32	25	38	32	150

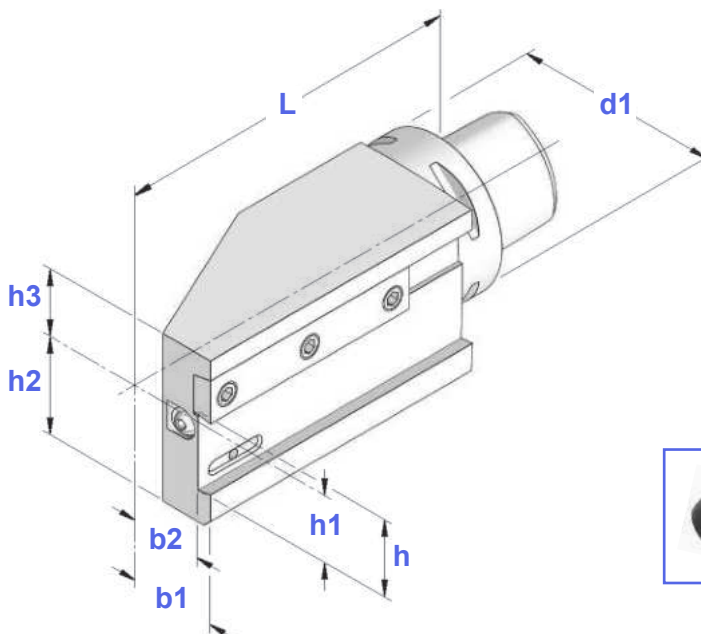

POLYGONAL

DIN ISO 26623-1

PORTALAMA SINISTRO

LEFT AXIAL TOOLHOLDER FOR CUT OFF TOOLS

TIPO	Art.	d1	b1	b2	h	h1	h2	h3	L
C 63 - C32L	11687	63	40	34	32	25	38	32	150

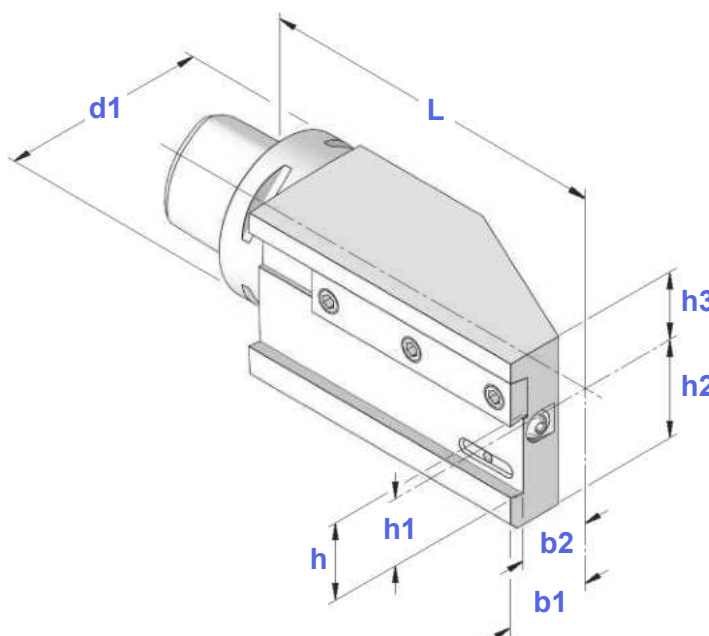

INDICE DEI MANDRINI ALTA VELOCITA'
CON FLANGIA SENZA TACCHE DI TRASCINAMENTO
INDEX OF HIGH SPEED SPINDLES WITHOUT LUGS ON THE FLANGE

PORTAPINZA ER
ghiera STANDARD
rotazione DESTRA

RIGHT SPIN ER STANDARD NUT
COLLET CHUCKS
pag. 218



PORTAPINZA ER
ghiera STANDARD
rotazione SINISTRA

LEFT SPIN ER STANDARD NUT
COLLET CHUCKS
pag. 218



PORTAPINZA ER
ghiera MINI

ER MINI NUT
COLLET CHUCKS
pag. 219



PORTAPINZA ER
MECCANICA CORTINI

MECCANICACORTINI ER
COLLET CHUCKS
pag. 219



PORTAPINZA ER
SCM MORBIDELLI

SCM MORBIDELLI ER
COLLET CHUCKS
pag. 219



PORTAPINZA EOC
SCM MORBIDELLI

SCM MORBIDELLI EOC
COLLET CHUCKS
pag. 219



CODOLI di AGGANCI

PULL STUDS
pag. 221



TAMPONI PULITORI

TAPER CLEANERS
pag. 243



SMONTACONI
ORIENTABILI

ORIENTABLE
TIGHTENING FIXTURES
pag. 240



MAGAZZINI PORTACONI

TOOL STORES
pag. 244 - 245



**MANDRINI CON FLANGIA SENZA TACCHE di TRASCINAMENTO
PORTAPINZA ER - GHIERA STANDARD**

SPINDLES WITHOUT LUGS ON THE FLANGE - ER COLLET CHUCKS with STANDARD NUT

Balanced	G 6,3
ISO 30	24.000 rpm
ISO 40	20.000 rpm

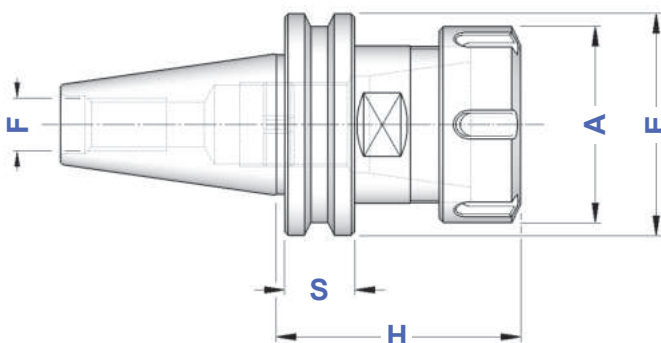

**ROTAZIONE DESTRA
RIGHT SPIN**

FLANGIA FLANGE	ROTAZIONE DESTRA RIGHT SPIN												
	TIPO	Art.	H	A	E	S	F	RANGE					
Ø 46	ISO 30 AV - ER 32/ H 60	2545 DX	60	50	46,00	15,9	M 12	ER32 2÷25	4996	3670	0988	0559	
	ISO 30 AV - ER 40/ H 65	2546 DX	65	63	46,00	15,9	M 12	ER40 3÷32	4997	3671	0821	0561	
Ø 50	ISO 30 AV - ER 32/ H 50	2519 DX	50	50	50,00	15,9	M 12	ER32 2÷25	4996	3670	0988	0559	
	ISO 30 AV - ER 32/ H 68	2520 DX	68	50	50,00	15,9	M 12	ER32 2÷25	4996	3670	0988	0559	
	ISO 30 AV - ER 40/ H 57	2562 DX	57	63	50,00	15,9	M 12	ER40 3÷32	4997	3671	0821	0561	
	ISO 30 AV - ER 40/ H 68	2563 DX	68	63	50,00	15,9	M 12	ER40 3÷32	4997	3671	0821	0561	
Ø 58	ISO 30 AV - ER 32/ H 63	2522 DX	63	50	58,00	15,9	M 12	ER32 2÷25	4996	3670	0988	0559	
	ISO 30 AV - ER 40/ H 65	2564 DX	65	63	58,00	15,9	M 12	ER40 3÷32	4997	3671	0821	0561	
Ø 58	ISO 40 AV - ER 32/ H 63	2567 DX	63	50	58,00	15,9	M 16	ER32 2÷25	4996	3670	0988	0559	
	ISO 40 AV - ER 40/ H 65	2523 DX	65	63	58,00	15,9	M 16	ER40 3÷32	4997	3671	0821	0561	
Ø 63,55	ISO 40 AV - ER 32/ H 68	2568 DX	68	50	63,55	15,9	M 16	ER32 2÷25	4996	3670	0988	0559	
	ISO 40 AV - ER 40/ H 68	2521 DX	68	63	63,55	15,9	M 16	ER40 3÷32	4997	3671	0821	0561	

**ROTAZIONE SINISTRA
LEFT SPIN**

FLANGIA FLANGE	ROTAZIONE SINISTRA LEFT SPIN												
	TIPO	Art.	H	A	E	S	F	RANGE					
Ø 46	ISO 30 AV - ER 32/ H 60	2545 SX	60	50	46,00	15,9	M 12	ER32 2÷25	3074	3670	0988	0560	
	ISO 30 AV - ER 40/ H 65	2546 SX	65	63	46,00	15,9	M 12	ER40 3÷32	3075	3671	0821	0580	
Ø 50	ISO 30 AV - ER 32/ H 50	2519 SX	50	50	50,00	15,9	M 12	ER32 2÷25	3074	3670	0988	0560	
	ISO 30 AV - ER 32/ H 68	2520 SX	68	50	50,00	15,9	M 12	ER32 2÷25	3074	3670	0988	0560	
	ISO 30 AV - ER 40/ H 57	2562 SX	57	63	50,00	15,9	M 12	ER40 3÷32	3075	3671	0821	0580	
	ISO 30 AV - ER 40/ H 68	2563 SX	68	63	50,00	15,9	M 12	ER40 3÷32	3075	3671	0821	0580	
Ø 58	ISO 30 AV - ER 32/ H 63	2522 SX	63	50	58,00	15,9	M 12	ER32 2÷25	3074	3670	0988	0560	
	ISO 30 AV - ER 40/ H 65	2564 SX	65	63	58,00	15,9	M 12	ER40 3÷32	3075	3671	0821	0580	



MANDRINI CON FLANGIA SENZA TACCHE di TRASCINAMENTO

PORTAPINZA ER - GHIERA MINI

SPINDLES WITHOUT LUGS ON THE FLANGE - ER COLLET CHUCKS with MINI NUT

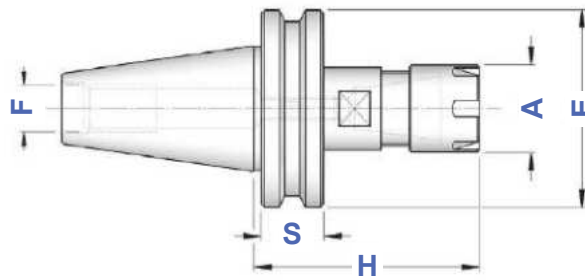
Balanced	G 6,3
ISO 20	40.000 rpm
ISO 30	24.000 rpm





TIPO	Art.	H	A	E	S	F	RANGE			
ISO 20 AV - ER16 GM/H 49	2571	49	22	30	15,9	M 8	ER16 1÷12	1229	5719	0364
ISO 30 AV - ER16 GM/H 60	4153	60	22	50	15,9	M 12	ER16 1÷12	1229	5719	0364
ISO 30 AV - ER20 GM/H 53	4171	53	28	50	15,9	M 12	ER20 1÷15	1230	5720	0787

MECCANICA CORTINI

PORTAPINZA ER - GHIERA MINI

ER COLLET CHUCKS with MINI NUT



TIPO	Art.	H	A	E	S	F	RANGE			
ISO30 CORTINI - ER 25 GM	3523	48	35	44	13	M 12	ER25 1÷20	1231	5721	0996

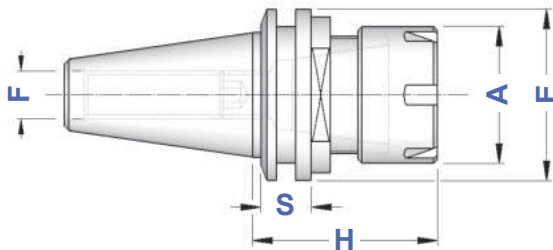

Codolo art. 0064 a pag. 231

Pull stud art. 0064 on page 231





SCM MORBIDELLI

PORTAPINZA ER / PORTAPINZA EOC

ER COLLET CHUCKS / EOC COLLET CHUCKS



TIPO	Art.	H	A	E	S	F	RANGE			
ISO 30 SCM - ER 32	2116	55	50	49	17	M 10	ER32 2÷25	4996	3670	0988
ISO 30 SCM - ER 40	2117	74	63	49	17	M 10	ER40 3÷32	4997	3671	0821
ISO 30 SCM - EOC 25	2118	70	60	49	17	M 10	EOC25 2÷25	4068	2909	0769

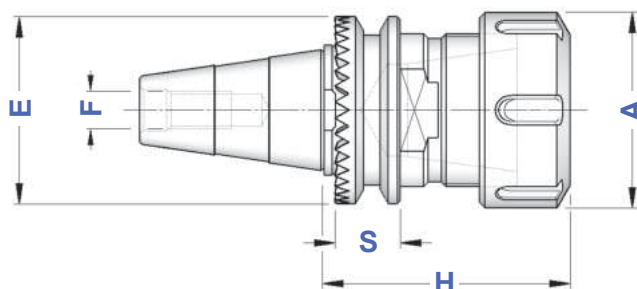

Codolo art. 3358 a pag. 234

Pull stud art. 3358 on page 234



Tabelle da completare per la richiesta di codoli speciali

Complete the following tables in order to ask for special pull studs

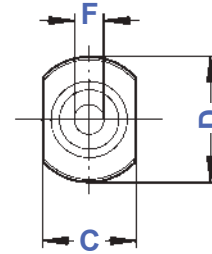
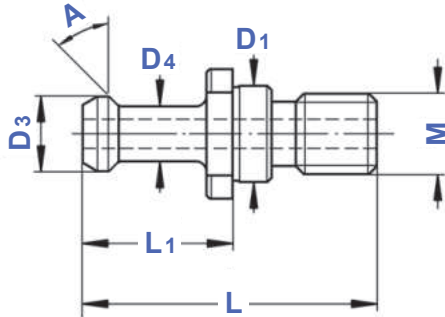

Costruttore / Brand

Modello Macchina / Machine Model

M
 L
 L1
 D
 D1

D3
 D4
 A
 C
 F

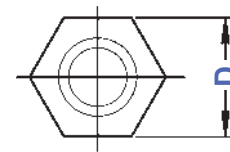
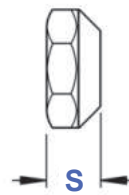
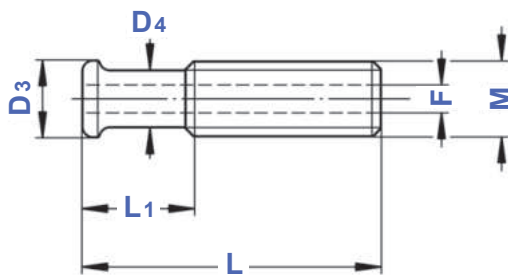

Costruttore / Brand

Modello Macchina / Machine Model

M
 L
 L1
 D

D3
 D4
 F
 S

INDICE DEI CODOLI DI AGGANCIO
INDEX OF PULL STUDS

DIN 69872



pag. 222

DIN 69872 ➔ **CONI BT**



pag. 223

DIN 7388/2 A



pag. 224

DIN 7388/2 B



pag. 225

BT



pag. 226

BT ➔ **CONI DIN 69871**



pag. 227

JIS B 6339



pag. 228

ISO 20



pag. 228

OTT



pag. 229

BIESSE



pag. 229

BRIDGEPORT



pag. 229

CHIRON



pag. 230

C.B. FERRARI



pag. 230

C.B. FERRARI CON DADO



pag. 230

CINCINNATI



pag. 230

CORREA



pag. 231

FAMUP



pag. 231

GLORIA



pag. 231

MAZAK



pag. 232

OKUMA



pag. 233

OLIVETTI



pag. 234

RAMBAUDI



pag. 234

SCM MORBIDELLI



pag. 234

SECMU



pag. 234



**DIN
69872**

CODOLI DIN 69872

DIN 69872 PULL STUDS (ISO 7388-3 form AD - AF)

NON FORATI
WITHOUT COOLANT BORE

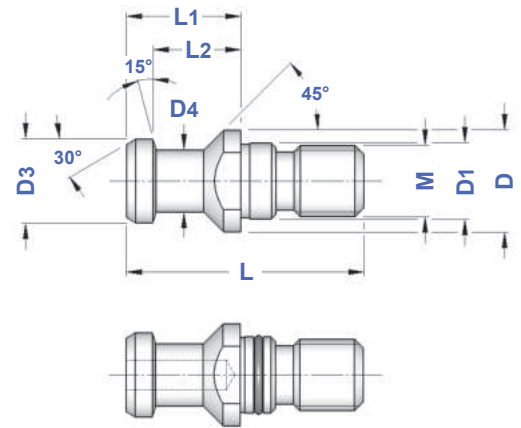

TIPO	Art.	Art.	M	D	D1	D3	D4	L	L1	L2
69872 ISO 30 - NON FORATO	3489	—	M12	17	13	13	9	44	24	19
69872 ISO 40 - NON FORATO	4573	3268	M16	23	17	19	14	54	26	20
69872 ISO 45 - NON FORATO	4574	—	M20	30	21	23	17	65	30	23
69872 ISO 50 - NON FORATO	4575	3270	M24	36	25	28	21	74	34	25

FORATI
WITH COOLANT BORE

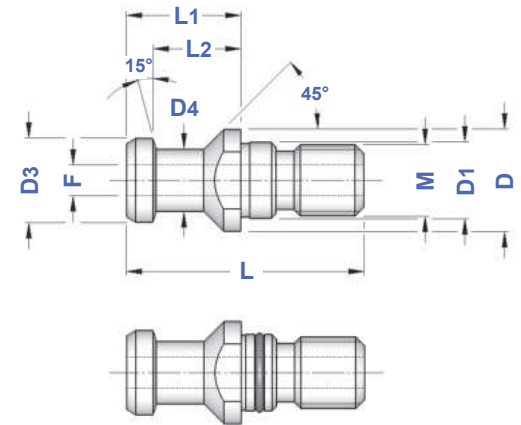

TIPO	Art.	Art.	M	D	D1	D3	D4	L	L1	L2	F
69872 ISO 30 - FORATO	3423	—	M12	17	13	13	9	44	24	19	3
69872 ISO 40 - FORATO	3476	3040	M16	23	17	19	14	54	26	20	7
69872 ISO 40 - OKUMA	—	4548	M16	23	17	19	14	54	26	20	4
69872 ISO 45 - FORATO	3477	—	M20	30	21	23	17	65	30	23	9,5
69872 ISO 50 - FORATO	3478	3042	M24	36	25	28	21	74	34	25	11,5

**FORATI con
DOPPIO OR**
WITH COOLANT BORE
and DOUBLE O-Ring

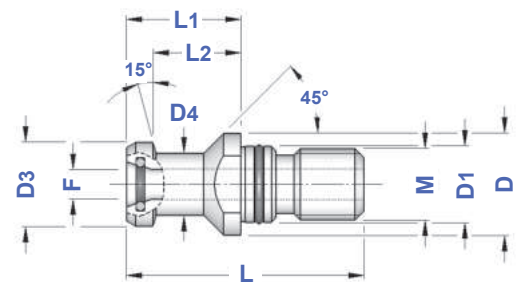
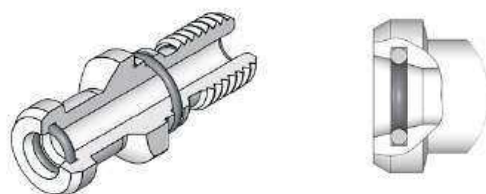

TIPO	Art.	M	D	D1	D3	D4	L	L1	L2	F
69872 ISO 40 - FORATO con DOPPIO OR	3222	M16	23	17	19	14	54	26	20	7
69872 ISO 50 - FORATO con DOPPIO OR	3223	M24	36	25	28	21	74	34	25	11,5

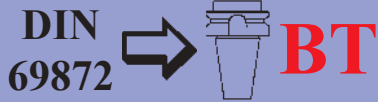

CODOLI TIPO DIN 69872 ADATTI per CONI BT
 DIN 69872 TYPE PULL STUDS suitable for BT SHANKS

NON FORATI
 WITHOUT COOLANT BORE

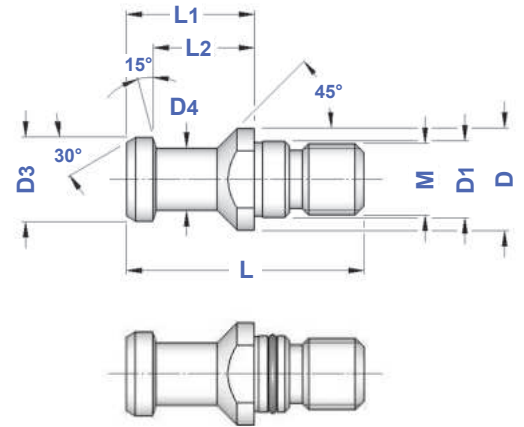

TIPO	Art.	Art.	M	D	D1	D3	D4	L	L1	L2
69872/ BT 40 - NON FORATO	3157	3158	M16	23	17	19	14	54	29	23

FORATI
 WITH COOLANT BORE

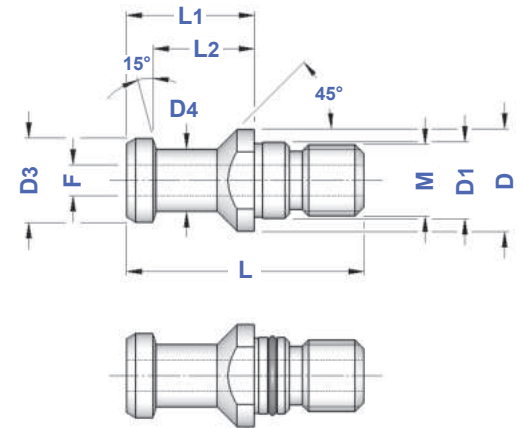

TIPO	Art.	Art.	M	D	D1	D3	D4	L	L1	L2	F
69872/ BT 40 - FORATO	3191	3192	M16	23	17	19	14	54	29	23	7

FORATI con DOPPIO OR
 WITH COOLANT BORE and DOUBLE O-Ring

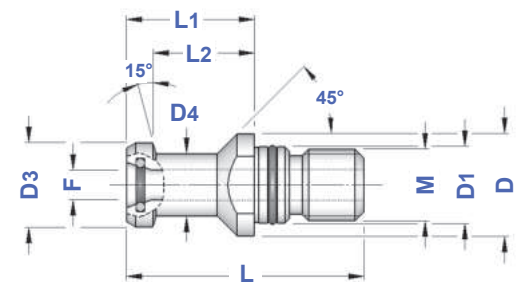
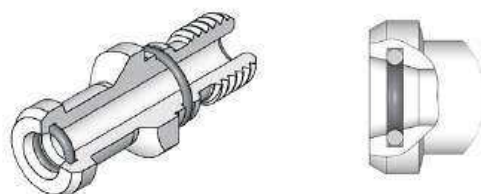

TIPO	Art.	M	D	D1	D3	D4	L	L1	L2	F
69872/ BT 40 - FORATO con DOPPIO OR	3403	M16	23	17	19	14	54	29	23	7



**ISO
7388/2A**

CODOLI ISO 7388/2A
ISO 7388/2A PULL STUDS

NON FORATI
WITHOUT COOLANT BORE

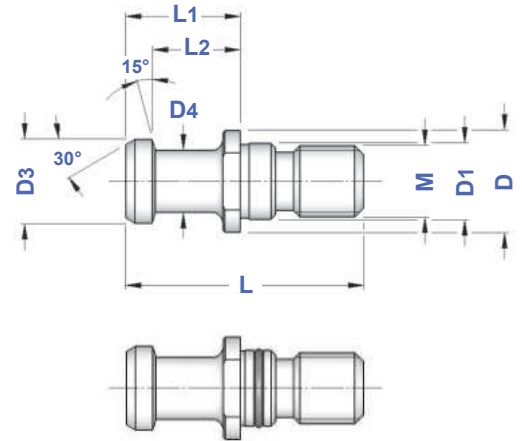

TIPO	Art.	Art.	M	D	D1	D3	D4	L	L1	L2
7388/2A ISO30 - NON FORATO	3479	—	M12	16	13	12	8	44	24	19
7388/2A ISO40 - NON FORATO	4576	4582	M16	23	17	19	14	54	26	20
7388/2A ISO45 - NON FORATO	4577	—	M20	30	21	23	17	65	30	23
7388/2A ISO50 - NON FORATO	4578	4584	M24	36	25	28	21	74	34	25

FORATI
WITH COOLANT BORE

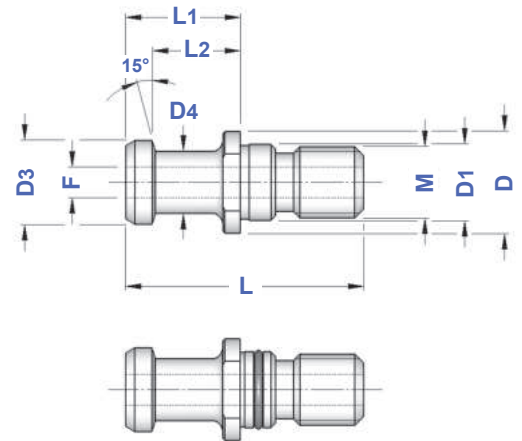

TIPO	Art.	Art.	M	D	D1	D3	D4	L	L1	L2	F
7388/2A ISO40 - FORATO	3480	3047	M16	23	17	19	14	54	26	20	7,0
7388/2A ISO45 - FORATO	3481	—	M20	30	21	23	17	65	30	23	9,5
7388/2A ISO50 - FORATO	3482	3049	M24	36	25	28	21	74	34	25	11,5

SEDE CHIP
ID COUNTERBORE

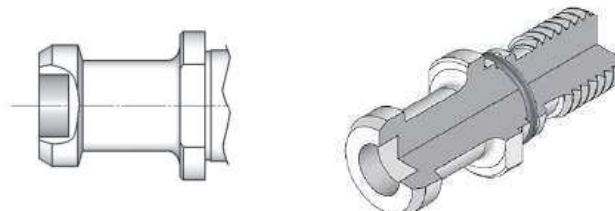

Si esegue sede chip su specifica del cliente
ID counterbore is carried out upon customer specification



**ISO
7388/2B**

CODOLI ISO 7388/2B

ISO 7388/2B PULL STUDS (ISO 7388-3 form UD - UF)

NON FORATI
WITHOUT COOLANT BORE

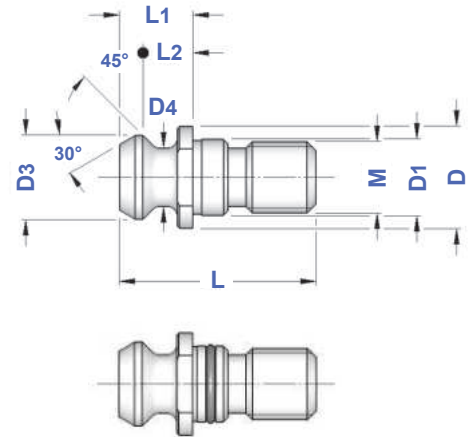

TIPO	Art.	Art.	M	D	D1	D3	D4	L	L1	L2
7388/2B ISO30 - NON FORATO	3483	—	M12	17	12,5	13,3	9,3	34	11,8	8,1
7388/2B ISO40 - NON FORATO	4579	4585	M16	22,5	17	18,9	12,9	44,5	16,4	11,1
7388/2B ISO45 - NON FORATO	4580	—	M20	30	21	24	16,3	56	20,9	14,8
7388/2B ISO50 - NON FORATO	4581	4587	M24	37	25	29,1	19,6	65,5	25,5	17,9

FORATI
WITH COOLANT BORE

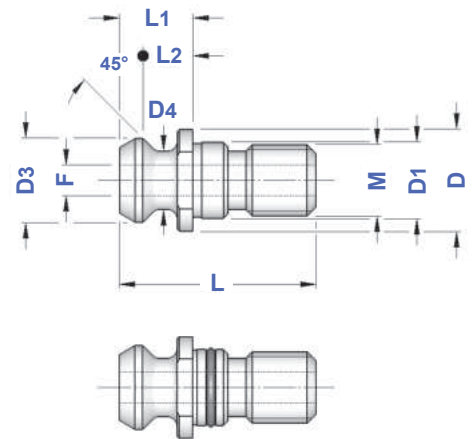

TIPO	Art.	Art.	M	D	D1	D3	D4	L	L1	L2	F
7388/2B ISO40 - FORATO	3484	3050	M16	22,5	17	18,9	12,9	44,5	16,4	11,1	7,3
7388/2B ISO45 - FORATO	3485	—	M20	30	21	24	16,3	56	20,9	14,8	9,2
7388/2B ISO50 - FORATO	3486	3052	M24	37	25	29,1	19,6	65,5	25,5	17,9	11,5

SEDE CHIP
ID COUNTERBORE

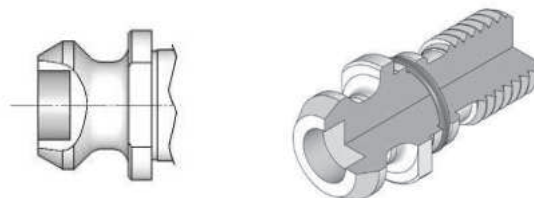

Si esegue sede chip su specifica del cliente
ID counterbore is carried out upon customer specification



**BT
MAS**

CODOLI BT

BT PULL STUDS (ISO 7388-3 form JD - JF)

NON FORATI
WITHOUT COOLANT BORE

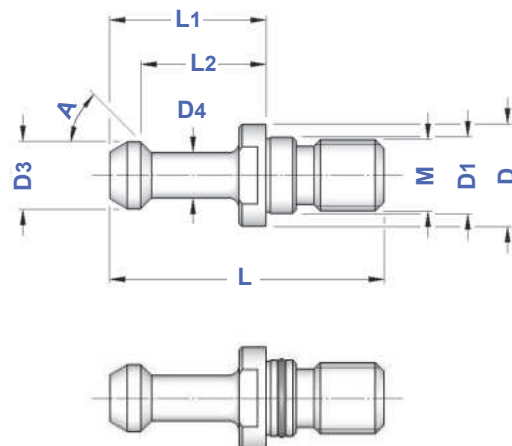

TIPO	Art.	Art.	A	M	D	D1	D3	D4	L	L1	L2
BT 30 - 45° NON FORATO	3288	—	45°	M12	16,5	12,5	11	7	43	23	18
BT 30 - 60° NON FORATO	3287	—	60°	M12	16,5	12,5	11	7	43	23	18
BT 35 - 45° NON FORATO	3290	—	45°	M12	20	13	13	8,5	48	28	22,5
BT 40 - 45° NON FORATO	3292	3316	45°	M16	23	17	15	10	60	35	28
BT 40 - 60° NON FORATO	3293	3315	60°	M16	23	17	15	10	60	35	28
BT 40 - 90° NON FORATO	3294	3318	90°	M16	23	17	15	10	60	35	28
BT 45 - 45° NON FORATO	3297	—	45°	M20	31	21	19	14	70	40	31
BT 45 - 60° NON FORATO	3298	—	60°	M20	31	21	19	14	70	40	31
BT 50 - 45° NON FORATO	3300	3325	45°	M24	38	25	23	17	85	45	35
BT 50 - 60° NON FORATO	3301	3322	60°	M24	38	25	23	17	85	45	35
BT 50 - 90° NON FORATO	3302	3326	90°	M24	38	25	23	17	85	45	35

FORATI
WITH COOLANT BORE

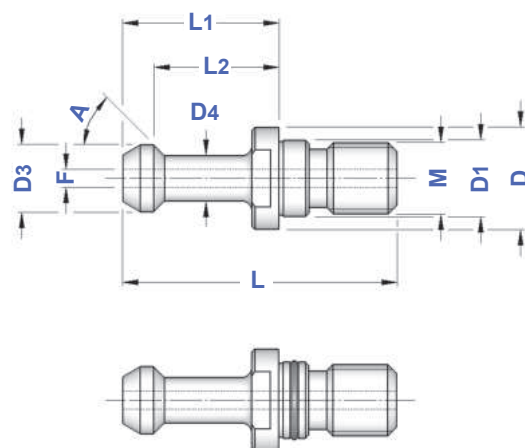

TIPO	Art.	Art.	A	M	D	D1	D3	D4	L	L1	L2	F
BT 30 - 45° FORATO	3225	—	45°	M12	16,5	12,5	11	7	43	23	18	2,5
BT 30 - 60° FORATO	3224	—	60°	M12	16,5	12,5	11	7	43	23	18	2,5
BT 40 - 45° FORATO	3328	3430	45°	M16	23	17	15	10	60	35	28	4
BT 40 - 60° FORATO	3327	3429	60°	M16	23	17	15	10	60	35	28	4
BT 40 - 90° FORATO	3330	3431	90°	M16	23	17	15	10	60	35	28	4
BT 50 - 45° FORATO	3332	3501	45°	M24	38	25	23	17	85	45	35	6
BT 50 - 60° FORATO	3331	3500	60°	M24	38	25	23	17	85	45	35	6
BT 50 - 90° FORATO	3333	3502	90°	M24	38	25	23	17	85	45	35	6

**BT
MAS**

CODOLI BT con DOPPIO OR
BT PULL STUDS with DOUBLE O-Ring

**FORATI con
DOPPIO OR**

WITH COOLANT BORE
and DOUBLE O-Ring

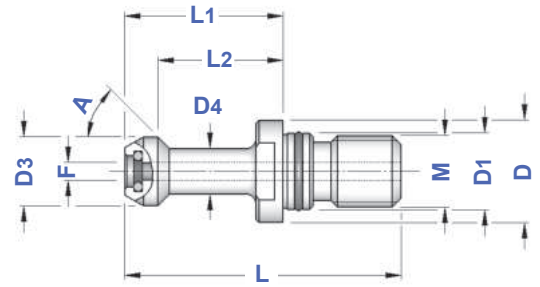
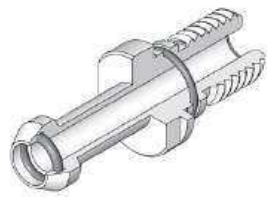

TIPO	Art.	A	M	D	D1	D3	D4	L	L1	L2	F
BT 40 - 45° FORATO con DOPPIO OR	3131	45°	M16	23	17	15	10	60	35	28	3
BT 40 - 60° FORATO con DOPPIO OR	3132	60°	M16	23	17	15	10	60	35	28	3
BT 50 - 45° FORATO con DOPPIO OR	3133	45°	M24	38	25	23	17	85	45	35	6
BT 50 - 60° FORATO con DOPPIO OR	3134	60°	M24	38	25	23	17	85	45	35	6
BT 50 - 90° FORATO con DOPPIO OR	3135	90°	M24	38	25	23	17	85	45	35	6

BT  **DIN
69871**

CODOLI TIPO BT ADATTI per CONI DIN 69871
BT TYPE PULL STUDS suitable for DIN 69871 SHANKS

NON FORATI

WITHOUT COOLANT BORE

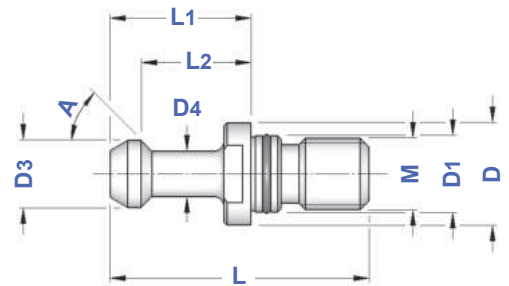

TIPO	Art.	Art.	A	M	D	D1	D3	D4	L	L1	L2
SK 40 - 45° NON FORATO	3291	4632	45°	M16	23	17	15	10	57	32	25
SK 40 - 60° NON FORATO	—	4631	60°	M16	23	17	15	10	57	32	25
SK 40 - 90° NON FORATO	3296	4633	90°	M16	23	17	15	10	57	32	25

FORATI

WITH COOLANT BORE

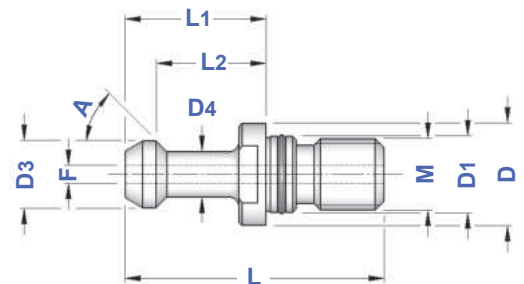

TIPO	Art.	Art.	A	M	D	D1	D3	D4	L	L1	L2	F
SK 40 - 45° FORATO	4635	4638	45°	M16	23	17	15	10	57	32	25	4
SK 40 - 60° FORATO	—	4637	60°	M16	23	17	15	10	57	32	25	4
SK 40 - 90° FORATO	—	4639	90°	M16	23	17	15	10	57	32	25	4



JIS B 6339

CODOLI JIS B 6339

JIS B 6339 PULL STUDS

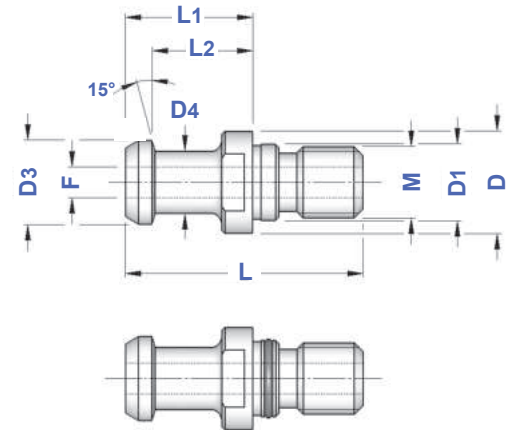

FORATI

WITH COOLANT BORE

senza OR
without OR

con OR
with OR



TIPO	Art.	Art.	M	D	D1	D3	D4	L	L1	L2	F
6339 ISO 30 - FORATO	3334	—	M12	16,5	12,5	12	8	43	23,4	18,4	4
6339 ISO 40 - FORATO	3084	3097	M16	23	17	19	14	54	29	23	4
6339 ISO 40 - FORATO	4588	3317	M16	23	17	19	14	54	29	23	7
6339 ISO 50 - FORATO	—	3335	M24	38	25	28	21	74	34	25	10

FORATI con RASAMENTO RETTIFICATO

WITH COOLANT BORE and GRINDED HEAD

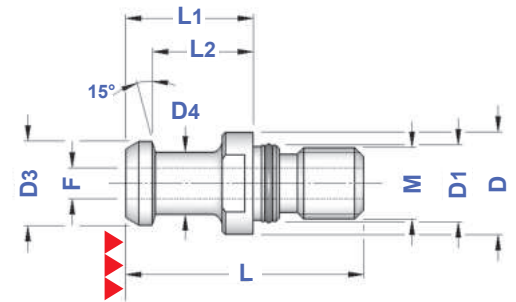

TIPO	Art.	M	D	D1	D3	D4	L	L1	L2	F
6339 ISO 40 - FORATO con RASAMENTO RETTIFICATO	4549	M16	23	17	19	14	54	29	23	4



ISO 20

CODOLI per ISO 20

PULL STUDS for ISO 20 SHANK

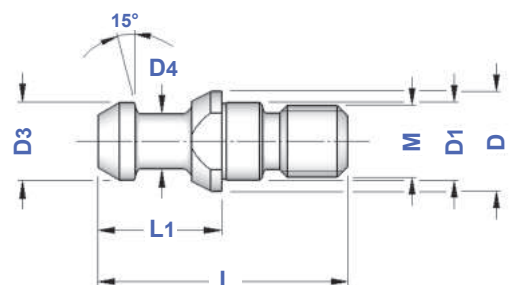

TIPO	Art.	M	D	D1	D3	D4	L	L1
ISO 20 - M 8 / L 28	3491	M 8	11	8,5	8,5	6	28	14



OTT

CODOLI OTT ADATTATORI a DIN 2080

OTT PULL STUDS ADAPTERS to DIN 2080

TIPO	Art.	M	M1	D	D1	L	L1	L2
OTT M16 - TC 40	3487	M16	M16	25,3	17	53	25	13,6
OTT M16 - BT 40	3466	M16	M16	25,3	17	56	28	16,6
OTT M24 - CONO 50	0087	M24	M24	39,6	25	65	25	13

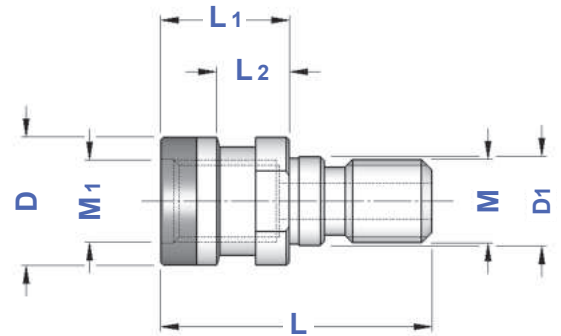
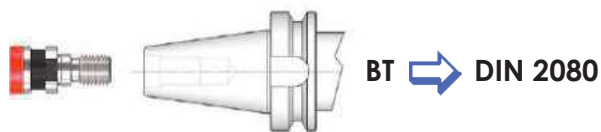

BIESSE

CODOLI BIESSE

BIESSE PULL STUDS

TIPO	Art.	M	D	D1	D3	D4	L	L1
BIESSE ISO 30 - M12	3492	M12	17	13	12	8	44	24

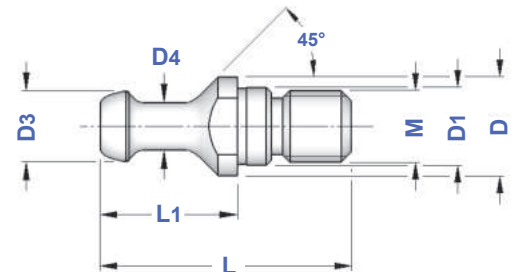

BRIDGEPORT

CODOLI BRIDGEPORT

BRIDGEPORT PULL STUDS

TIPO	Art.	M	D	D1	D3	D4	L	L1	L2	F
BRIDGEPORT ISO 40 - M16	3359	M16	23	17	19	14	54	29	23	7

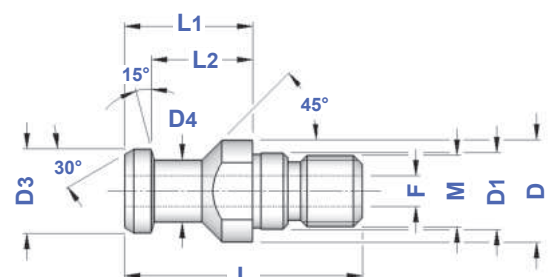



C.B. FERRARI	CODOLI C.B. FERRARI <i>C.B. FERRARI PULL STUDS</i>
-------------------------	--

TIPO	Art.	M	D	D1	D3	D4	L	L1	L2	F
C.B. FERRARI ISO40 - M16	4597	M16	23	17	19	15	54	26	20,31	5

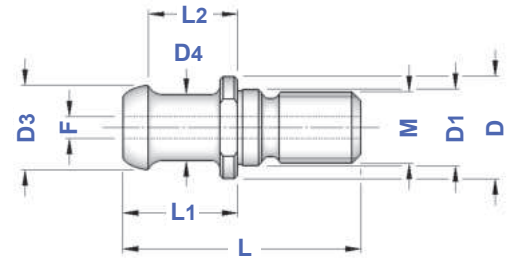

C.B. FERRARI con DADO
C.B. FERRARI WITH NUT

TIPO	Art.	M	D3	D4	L	L1	F
C.B. FERRARI ISO40 - M16/DADO	3493	M16	16	12	57	18,5	5

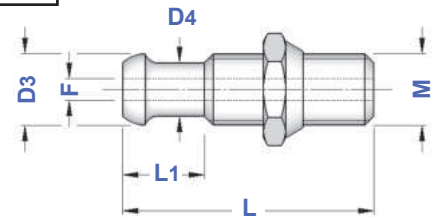

CHIRON	CODOLI CHIRON <i>CHIRON PULL STUDS</i>
---------------	--

TIPO	Art.	M	D1	D3	D4	L	L1	L2
CHIRON ISO30 - M12	4593	M12	13	10	6	36	20	16

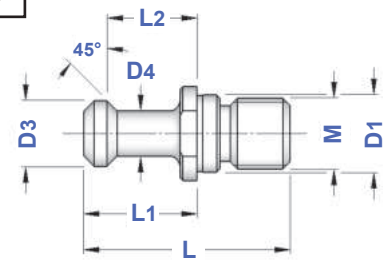

CINCINNATI	CODOLI CINCINNATI <i>CINCINNATI PULL STUDS</i>
-------------------	--

TIPO	Art.	M	L	L1	L2	D	D1	D3	D4	F
CINCINNATI ISO 40 - M16 / L1=36,6	4583	M16	67,3	36,6	29	22,2	17	15	10,3	3,8
CINCINNATI ISO 40 - M16 / L1=39,4	4586	M16	67,3	39,4	31,75	22,2	17	15	10,3	3,8

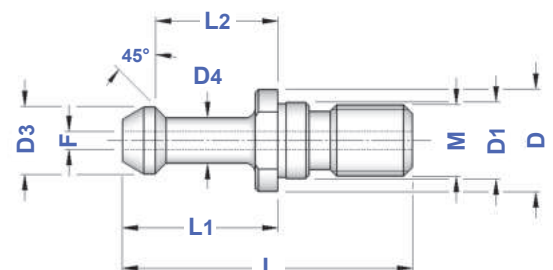



CORREA

CODOLI CORREA CORREA PULL STUD BOLTS

TIPO	Art.	M	D	D3	D4	L	L1
CORREA ISO 50 - M 24	4594	M 24	36	20	16	76	36

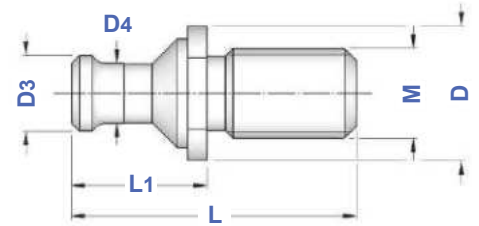

CORTINI

CODOLI MECCANICA CORTINI MECCANICA CORTINI PULL STUDS

TIPO	Art.	M	D	D1	D3	D4	L	L1
CORTINI ISO 30 - M12	0064	M12	16	13	10	7	39	21

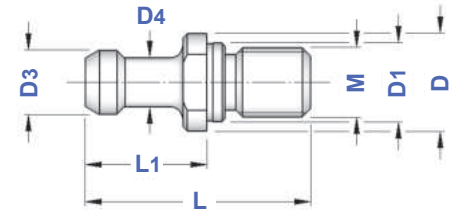

FAMUP

CODOLI FAMUP FAMUP PULL STUDS

TIPO	Art.	M	D	D1	D3	D4	L	L1
FAMUP ISO 30 - M12	2756	M 12	16	13	9,8	5,8	40	20
FAMUP ISO 40 - M16 / L=55	3527	M 16	23	17	13,8	9,8	55	27
FAMUP ISO 40 - M16 / L=58	4590	M 16	23	17	13,8	9,8	58	30

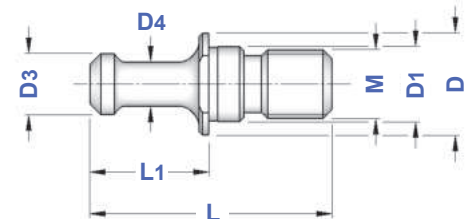

GLORIA

CODOLI GLORIA GLORIA PULL STUDS

TIPO	Art.	M	D	D1	D3	D4	L	L1
GLORIA ISO 40 - M16	3471	M 16	23	17	16	12	45	18

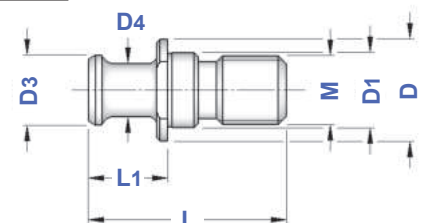



MAZAK

CODOLI MAZAK
MAZAK PULL STUDS

NON FORATI
WITHOUT COOLANT BORE

senza OR
without OR



con OR
with OR

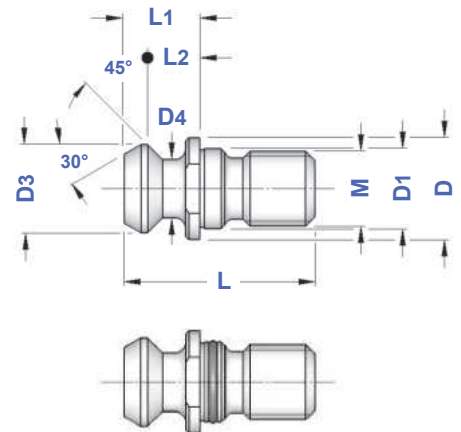

TIPO	Art.	Art.	M	D	D1	D3	D4	L	L1	L2	
MAZAK SK 40 - NON FORATO	4541	4542	M16	21,8	17	18,79	12,44	41,25	16,25	11,17	DIN69871/CAT
MAZAK BT 40 - NON FORATO	4543	4544	M16	22	17	18,79	12,44	44,10	19,10	14,02	BT

FORATI
WITH COOLANT BORE

senza OR
without OR



con OR
with OR

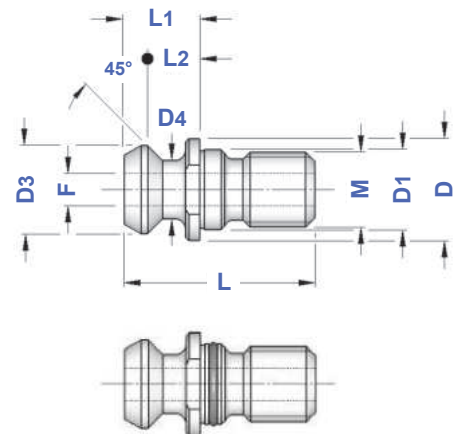

TIPO	Art.	Art.	M	D	D1	D3	D4	L	L1	L2	F	
MAZAK SK 40 - FORATO	4589	4772	M16	21,8	17	18,79	12,44	41,25	16,25	11,17	7	DIN69871/CAT
MAZAK BT 40 - FORATO	4592	4773	M16	22	17	18,79	12,44	44,10	19,10	14,02	7	BT
MAZAK SK 50 - FORATO	4776	4777	M24	35,5	25	28,95	20,82	65,40	25,40	17,78	10	DIN69871/CAT
MAZAK BT 50 - FORATO	4778	4779	M24	37	25	28,95	20,82	65,20	25,20	17,58	10	BT

FORATI con LAMATURA
WITH COOLANT BORE and COUNTERBORE

senza OR
without OR



con OR
with OR

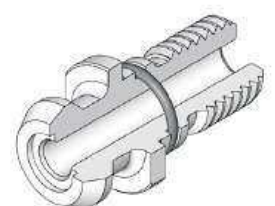
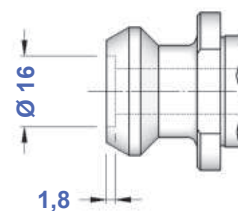

TIPO	Art.	Art.	M	D	D1	D3	D4	L	L1	L2	F	
MAZAK SK 50 con LAMATURA	3269	4774	M24	35,5	25	28,95	20,82	65,40	25,40	17,78	10	DIN69871/CAT
MAZAK BT 50 con LAMATURA	3352	4775	M24	37	25	28,95	20,82	65,20	25,20	17,58	10	BT



**OKUMA
for DIN**

CODOLI OKUMA (per DIN)
OKUMA PULL STUDS (for DIN)

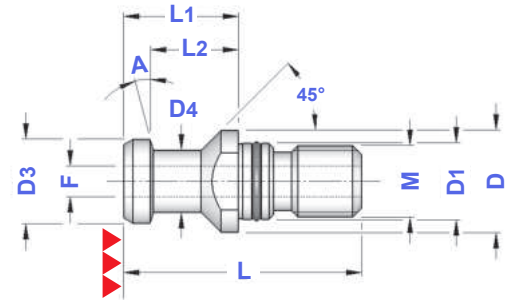

**FORATI con
RASAMENTO
RETTIFICATO**

WITH COOLANT BORE
and GRINDED HEAD

TIPO	Art.	M	D	D1	D3	D4	L	L1	L2	F	A
OKUMA SK 40 - FORATO	4548	M16	23	17	19	14	54	26	20	4	15°



Figura 1

Figura 2



Figura 1

Figura 2

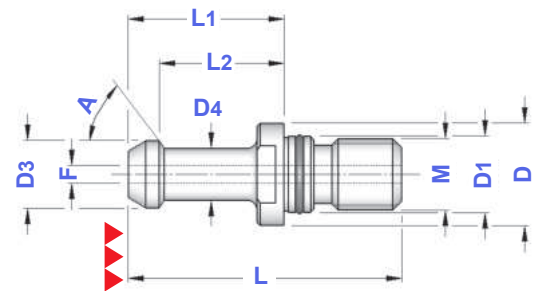
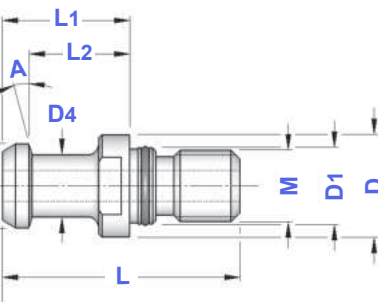

**FORATI con
RASAMENTO
RETTIFICATO**

WITH COOLANT BORE
and GRINDED HEAD

TIPO	Art.	M	D	D1	D3	D4	L	L1	L2	F	A	Fig.
OKUMA BT 40 - FORATO	4549	M16	23	17	19	14	54	29	23	4	15°	1
OKUMA BT 50 - FORATO	4550	M24	38	25	23	17	85	45	35	6	60°	2



OLIVETTI

CODOLI OLIVETTI OCN

OLIVETTI OCN PULL STUDS

TIPO	Art.	M	D	D1	D3	D4	L	L1
OLIVETTI ISO 40 - M16	4591	M16	23	17	14,3	10	58	33

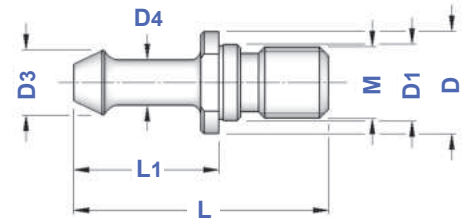

RAMBAUDI

CODOLI RAMBAUDI

RAMBAUDI PULL STUDS

TIPO	Art.	M	D	D1	D3	D4	L	L1
RAMBAUDI ISO 40 - M16	4595	M16	24	17	14,6	10	52	27
RAMBAUDI ISO 50 - M24	4596	M24	35,8	25	20	16	79,5	39,5

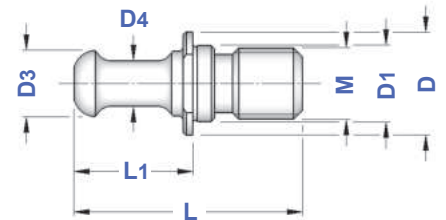

SCM MORBIDELLI

CODOLI SCM / MORBIDELLI

SCM / MORBIDELLI PULL STUDS

TIPO	Art.	M	D	D1	D3	D4	L	L1
SCM/MORBIDELLI ISO 30 - M10	3358	M10	15	11	8,5	6,5	42,5	21,9

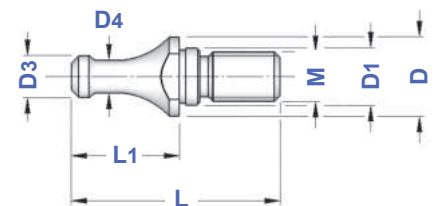

SECMU

CODOLI SECMU

SECMU PULL STUDS

TIPO	Art.	M	D	D1	D3	D4	L	L1	C
SECMU ISO 50 - M24	3496	M24	40	25	17,5	9,8	64	29	36

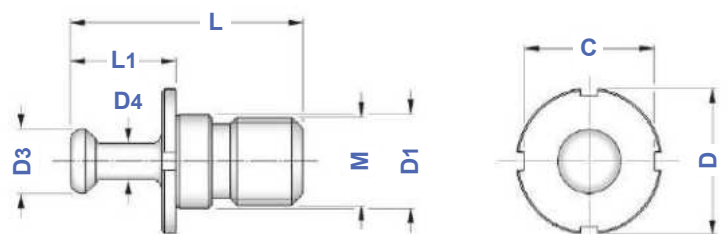

INDICE DELLE BUSSOLE PER MASCHIATORI A CAMBIO RAPIDO
INDEX OF TAPPING ADAPTERS FOR QUICK CHANGE TAPPING CHUCKS

**bussole
SENZA FRIZIONE**
WITHOUT CLUTCH

pag. 236



**bussole
SENZA FRIZIONE
CON GRANI**
*WITHOUT CLUTCH
WITH SCREWS*

pag. 236



**bussole
CON FRIZIONE**
WITH CLUTCH

pag. 237



**bussole
CON FRIZIONE
CON GRANI**
*WITH CLUTCH
WITH SCREWS*

pag. 237



**riduzioni da
BUSSOLA a BUSSOLA**
*reduction from
ADAPTER to ADAPTER*

pag. 238



**bussole porta maschi
con PINZA ER**
*tapping adapters
with ER COLLET*

pag. 238



**bussole
PORTA FILIERA**
*TRHEADING DIE
ADAPTERS*

pag. 238



**KIT di BUSSOLE
SENZA FRIZIONE**

*EQUIPMENT CASES of TAPPING
ADAPTERS WITHOUT CLUTCH*
pag. 236



**KIT di BUSSOLE
CON FRIZIONE**

*EQUIPMENT CASES of TAPPING
ADAPTERS WITH CLUTCH*
pag. 237



B

BUSSOLE PORTAMASCHI SENZA FRIZIONE

TAPPING ADAPTERS WITHOUT CLUTCH



TIPO	Art.	FILETTO	G	B	D	L
B.0	4077	M 2 ÷ M 10	∅ 2,5 ÷ ∅ 8	13	22	19,5
B.1	3390	M 2 ÷ M 12 (*M18)	∅ 2,5 ÷ ∅ 11 (*∅14)	19	30	21,5
B.2	3391	M 5 ÷ M 20 (*M30)	∅ 6,0 ÷ ∅ 18 (*∅22)	31	46	35,0
B.3	3392	M 14 ÷ M 36 (*M48)	∅11,0 ÷ ∅ 28 (*∅36)	48	68	55,5

* Bussole con GRANI
Adapters with SCREWS

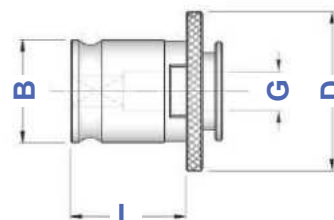

KIT di BUSSOLE SENZA FRIZIONE

EQUIPMENT CASES FOR TAPPING CHUCKS
OF TAPPING ADAPTERS WITHOUT CLUTCH



TIPO	Art.		
Corredo B.1	7532	3695	6 Bussole Art.3390: ∅ 3,5 (M3) - ∅ 4,5 (M 4) - ∅ 6 (M 6) ∅ 8 (M8) - ∅ 9 (M12) - ∅ 10 (M10)
Corredo B.2	7533	3695	7 Bussole Art.3391: ∅ 8 (M 8) - ∅ 9 (M12) - ∅ 10 (M10) ∅ 11 (M14) - ∅ 12 (M16) - ∅ 14 (M18) ∅ 16 (M20)

E' possibile completare il corredo aggiungendo il maschiatore di Vostro interesse
Is possible to complete the equipment adding the Tapping Chuck you are interested on

B - GR

BUSSOLE PORTAMASCHI SENZA FRIZIONE - CON GRANI

TAPPING ADAPTERS WITHOUT CLUTCH - WITH SCREWS



TIPO	Art.	FILETTO	G	B	D	L
B.1 - GR	3390 GR	M 16 ÷ M 18	∅ 12 - ∅ 14	19	30	21,5
B.2 - GR	3391 GR	M 27 ÷ M 30	∅ 20 - ∅ 22	31	46	35,0
B.3 - GR	3392 GR	M 39 ÷ M 48	∅ 32 - ∅ 36	48	68	55,5

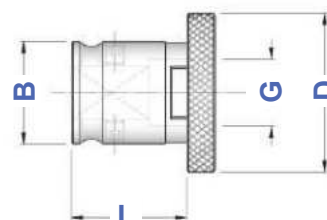

Nelle bussole tipo GR il fissaggio del maschio avviene mediante grani situati sul diametro di guida, questo consente la presa di misure maggiori

On GR tapping adapters, the tapping tool is locked by screws on guide diameter, this makes possible bigger sizes clamping.

BF

BUSSOLE PORTAMASCHI CON FRIZIONE

TAPPING ADAPTERS WITH CLUTCH



TIPO	Art.	FILETTO	G	B	D	L
BF.0	4078	M 2 ÷ M 10	∅ 2,5 ÷ ∅ 8	13	23	19,5
BF.1	3387	M 2 ÷ M 12 (*M18)	∅ 2,5 ÷ ∅ 12 (*∅14)	19	32	21,5
BF.2	3388	M 5 ÷ M 20 (*M30)	∅ 6,0 ÷ ∅ 18 (*∅22)	31	50	35,0
BF.3	3389	M14 ÷ M36 (*M48)	∅11,0 ÷ ∅ 28 (*∅36)	48	72	55,5

* Bussole con GRANI
Adapters with SCREWS

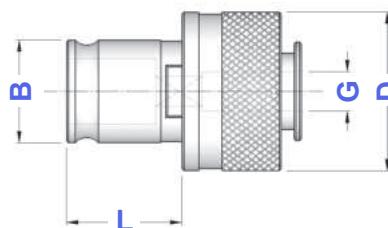

KIT di BUSSOLE CON FRIZIONE

EQUIPMENT CASES FOR TAPPING CHUCKS
OF TAPPING ADAPTERS WITH CLUTCH



TIPO	Art.		
Corredo BF.1	7534	3695	6 Bussole Art.3387: ∅ 3,5 (M 3) - ∅ 4,5 (M 4) - ∅ 6 (M 6) ∅ 8 (M 8) - ∅ 9 (M12) - ∅ 10 (M10)
Corredo BF.2	7535	3695	7 Bussole Art.3388: ∅ 8 (M 8) - ∅ 9 (M12) - ∅ 10 (M10) ∅ 11 (M14) - ∅ 12 (M16) - ∅ 14 (M18) ∅ 16 (M20)

E' possibile completare il corredo aggiungendo il maschiatore di Vostro interesse
Is possible to complete the equipment adding the Tapping Chuck you are interested on

BF - GR

BUSSOLE PORTAMASCHI CON FRIZIONE - CON GRANI

TAPPING ADAPTERS WITH CLUTCH - WITH SCREWS



TIPO	Art.	FILETTO	G	B	D	L
BF.1 - GR	3387 GR	M 16 ÷ M 18	∅ 14	19	32	21,5
BF.2 - GR	3388 GR	M 27 ÷ M 30	∅ 20 - ∅ 22	31	50	35,0
BF.3 - GR	3389 GR	M 39 ÷ M 48	∅ 32 - ∅ 36	48	72	55,5

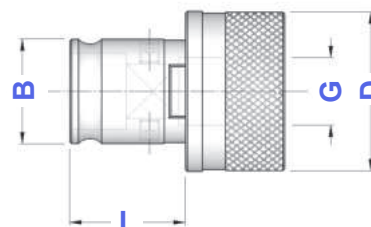

Nelle bussole tipo GR il fissaggio del maschio avviene mediante grani situati sul diametro di guida, questo consente la presa di misure maggiori

On GR tapping adapters, the tapping tool is locked by screws on guide diameter, this makes possible bigger sizes clamping.

RIDUZIONI

RIDUZIONI DA BUSSOLA A BUSSOLA

REDUCTIONS FROM ADAPTER TO ADAPTER

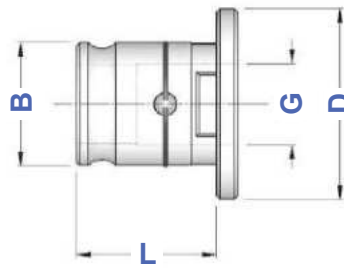



TIPO	Art.	B	G	D	L
B.1/B.0	0202	19	13	30	21,5
B.2/B.1	0246	31	19	48	35,0
B.3/B.1	0397	48	19	70	55,5
B.3/B.2	0399	48	31	70	55,5

PORTAPINZE

BUSSOLA PORTA MASCHI con PINZA ER

TAPPING ADAPTERS WITH ER COLLET



TIPO	Art.	B	A	H	L	RANGE			
B.1 - ER 16	3385	19	32	29	21,5	ER 16 1÷12	4993	3698	0364
B.2 - ER 25	3386	31	42	38	35,0	ER 25 1÷20	4995	3669	0996
B.2 - ER 32	3160	31	50	62	35,0	ER 32 2÷25	4996	3670	0988

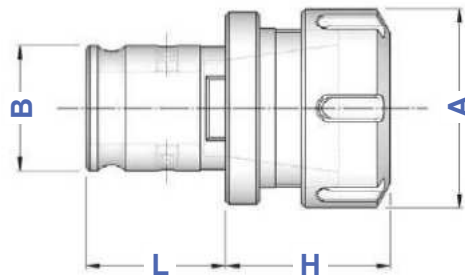

Il bloccaggio del quadro del maschio avviene mediante i grani posti sul diametro di guida.

Tapping tool square is locked by the screws on guide diameter.



PORTA FILIERA

BUSSOLE PORTA FILIERA

THREADING DIE ADAPTERS

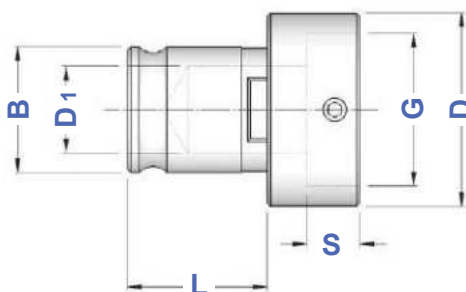

TIPO	Art.	B	L	G	S	D	D1
B.1 - F / 16 x 5	0251	19	21,5	16	4,8	25	12,5
B.1 - F / 20 x 5				20	4,8	30	12,5
B.1 - F / 20 x 7				20	6,5	30	12,5
B.1 - F / 25 x 9				25	8,5	35	12,5
B.1 - F / 30 x 11				30	10,0	40	12,5
B.1 - F / 38 x 10				38	9,0	48	14,2
B.1 - F / 38 x 14				38	13,0	48	14,2
B.2 - F / 20 x 5	0252	31	35,0	20	4,8	30	15,0
B.2 - F / 20 x 7				20	6,5	30	15,0
B.2 - F / 25 x 9				25	8,5	35	15,0
B.2 - F / 30 x 11				30	10,0	40	22,0
B.2 - F / 38 x 10				38	9,0	48	22,0
B.2 - F / 38 x 14				38	13,0	48	22,0
B.2 - F / 45 x 14				45	13,0	57	22,0
B.2 - F / 45 x 18				45	17,0	57	22,0

DIMENSIONAMENTO GAMBI PER MASCHI METRICI

SHANKS DIMENSIONS FOR METRIC TAPPING TOOLS



GAMBO ∅ x □	NORMALE DIN 352	RINFORZATO DIN 371	NORMALE DIN 376	NORMALE ISO	RINFORZATO ISO	TIPO BUSSOLA
2,50 x 2,10	M 1,0	M 1,0	M 3,5			0 - 1
	M 1,4	M 1,4				0 - 1
	M 1,6	M 1,6				0 - 1
	M 1,8	M 1,8				0 - 1
2,80 x 2,10	M 2,0	M 2,0	M 4,0			0 - 1
	M 2,2	M 2,2				0 - 1
	M 2,5	M 2,5				0 - 1
3,15 x 2,50				M 4,0	M 3,0	0 - 1
3,50 x 2,70	M 3,0	M 3,0	M 5,0			0 - 1
3,55 x 2,80				M 4,5	M 3,5	0 - 1
4,00 x 3,15	M 3,5	M 3,5		M 5,0	M 4,0	0 - 1
4,50 x 3,40	M 4,0	M 4,0	M 6,0			0 - 1
5,00 x 4,00					M 5,0	0 - 1
5,50 x 4,30			M 7,0			0 - 1
5,60 x 4,50				M 7,0		0 - 1
6,00 x 4,90	M 5,0	M 5,0				0 - 1 - 2
	M 6,0	M 6,0				0 - 1 - 2
	M 8,0		M 8,0			0 - 1 - 2
6,30 x 5,00				M 8,0	M 6,0	0 - 1 - 2
7,00 x 5,50	M 10,0		M 10,0			0 - 1 - 2
7,10 x 5,60				M 9,0		0 - 1 - 2
8,00 x 6,20		M 8,0		M 10,0	M 8,0	0 - 1 - 2
9,00 x 7,00	M 12,0		M 12,0	M 12,0		1 - 2
10,00 x 8,00		M 10,0			M 10,0	1 - 2
11,00 x 9,00	M 14,0		M 14,0			1 - 2 - 3
11,20 x 9,00				M 14,0		1 - 2 - 3
12,00 x 9,00	M 16,0		M 16,0			1 - 2 - 3
12,50 x 10,00				M 16,0		2 - 3
14,00 x 11,00	M 18,0		M 18,0			2 - 3
14,00 x 11,20				M 18,0		2 - 3
				M 20,0		2 - 3
16,00 x 12,00	M 20,0		M 20,0			2 - 3
16,00 x 12,50				M 22,0		2 - 3
18,00 x 14,00				M 24,0		2 - 3
18,00 x 14,50	M 22,0		M 22,0			2 - 3
	M 24,0		M 24,0			2 - 3
20,00 x 16,00	M 27,0		M 27,0	M 27,0		2 - 3
				M 30,0		2 - 3
22,00 x 18,00	M 30,0		M 30,0			2 - 3
25,00 x 20,00	M 33,0		M 33,0	M 36,0		3
28,00 x 22,00	M 36,0		M 36,0			3
32,00 x 24,00	M 39,0		M 39,0			3
	M 42,0		M 42,0			3
36,00 x 29,00	M 45,0		M 45,0			3
	M 48,0		M 48,0			3

**ATTREZZI
SMU**

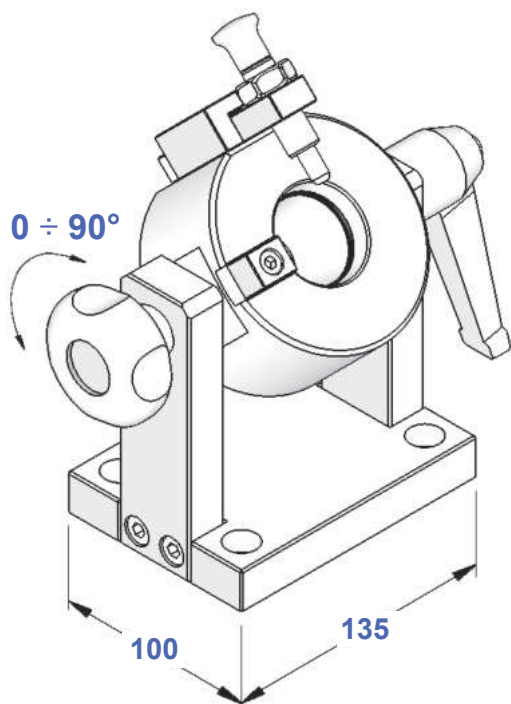
SMONTACONI ORIENTABILI ISO
DIN 2080 - DIN 69871 - BT - coni DOPPIO CONTATTO
ORIENTABLE TIGHTENING FIXTURES NT - SK - BT - DOUBLE CONTACT SHANKS



ISO DIN 2080 - DIN 69871 - BT
e coni DOPPIO CONTATTO
ISO and DOUBLE CONTACT SHANKS

TIPO	Art.			
SMU - CONO 30	4438	1031	1032	1033
SMU - CONO 40	4439			
SMU - CONO 45	4440			
SMU - CONO 50	4441			

**Il bloccaggio sulla flangia
è garantito dal sistema a molla**
*Flange locking is guaranteed
by the spring system*

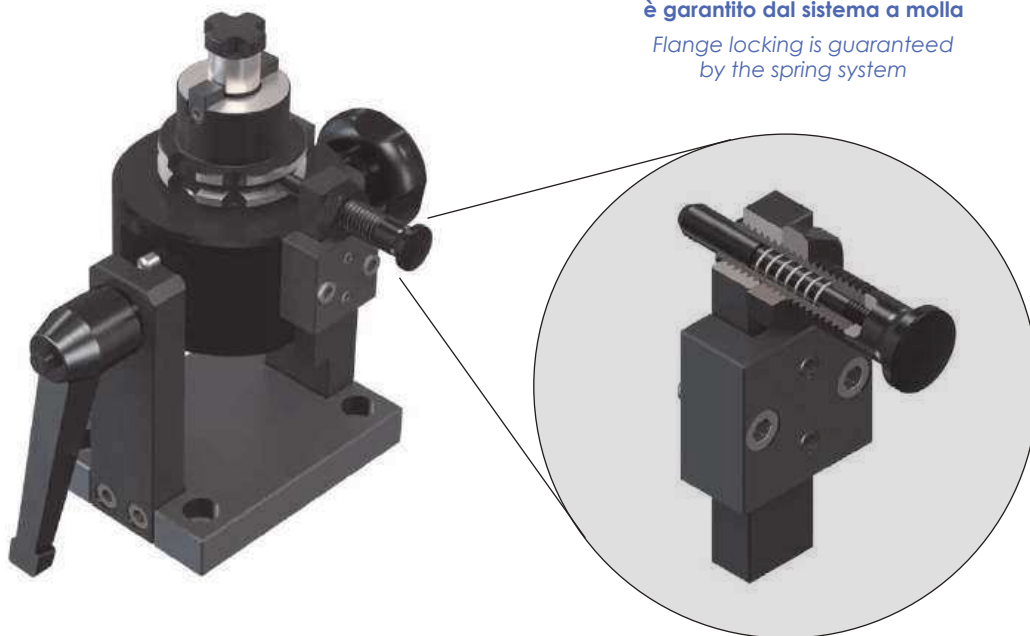

**ATTREZZI
SMU**

SMONTACONI ORIENTABILI ATTACCHI HSK E POLIGONALI

ORIENTABLE TIGHTENING FIXTURES HSK and POLYGONAL SHANKS



HSK DIN 69893 (A+C - B+D - E - F)

HSK DIN 69893 SHANKS

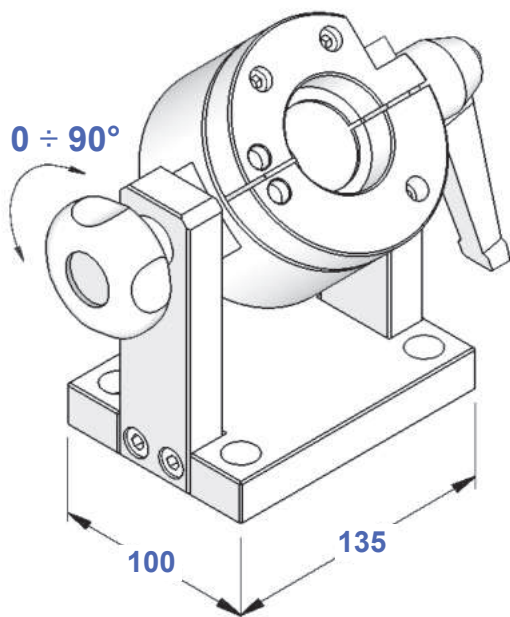

TIPO	Art.
SMU - HSK 25	4598
SMU - HSK 32	4599
SMU - HSK 40	4600
SMU - HSK 50	4601
SMU - HSK 63	4602
SMU - HSK 80	4603
SMU - HSK 100	4604

		1032	1033

POLIGONALI (ISO 26623-1)

POLYGONAL SHANKS

TIPO	Art.
SMU - POLIGONALE C 32	4599
SMU - POLIGONALE C 40	4600
SMU - POLIGONALE C 50	4601
SMU - POLIGONALE C 63	4602
SMU - POLIGONALE C 80	4603
SMU - POLIGONALE C100	4604

		1032	1033

Aperto
Open



Chiuso
Closed



Il bloccaggio del mandrino avviene sulla flangia mediante la chiusura a morsa

The spindle is locked on the flange by means of vise closure

**ATTREZZI
BMU**

BOCCOLE DI MONTAGGIO in ACCIAIO
STEEL TOOLING CLAMPERS

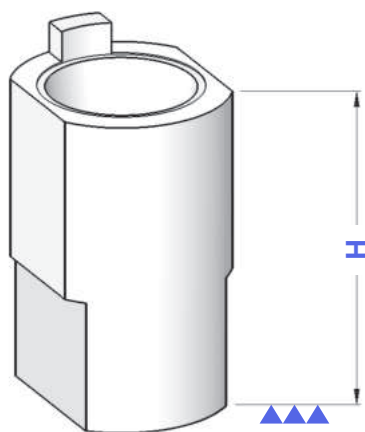

TIPO	Art.	H
BMU - CONO 30	2190	70
BMU - CONO 40	2191	95
BMU - CONO 50	2193	130

Costruiti in acciaio temperato,
bruniti e rettificati

Made with hardened steel,
burnished and grinded

**ATTREZZI
SMD**

SUPPORTI DI MONTAGGIO A 2 POSIZIONI
DOUBLE POSITION TIGHTENING FIXTURES



Figura 1



Figura 2

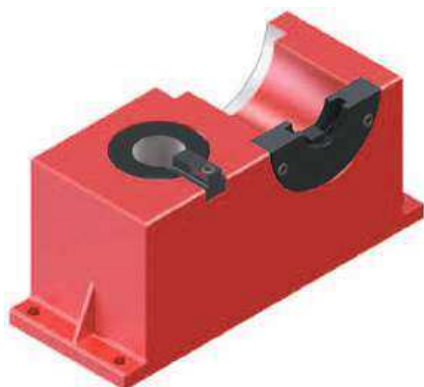

Figura 3

TIPO	Art.	Figura	L x P x H
SMD - ISO 40 / DIN 2080	4606	1	350 x 135 x 155
SMD - ISO 50 / DIN 2080	4607		
SMD - TC 40 / DIN 69871	4609		
SMD - TC 50 / DIN 69871	4610		
SMD - TC 40 DOPPIO CONTATTO	8498		
SMD - TC 50 DOPPIO CONTATTO	8499		
SMD - BT 30 / MAS 403	4611		
SMD - BT 40 / MAS 403	4612		
SMD - BT 50 / MAS 403	4613		
SMD - BT 30 DOPPIO CONTATTO	8500		
SMD - BT 40 DOPPIO CONTATTO	8501		
SMD - BT 50 DOPPIO CONTATTO	8502		

TIPO	Art.	Figura	L x P x H
SMD - HSK 63A+C	4621	2	350 x 135 x 155
SMD - HSK 100 A+C	4622		
SMD - HSK 63 E	4625		
SMD - HSK 63 F	4625		

TIPO	Art.	Figura	L x P x H
SMD - POLIGONALE C 40	9495	3	350 x 135 x 155
SMD - POLIGONALE C 50	9496		
SMD - POLIGONALE C 63	9497		
SMD - POLIGONALE C 80	9498		

TP

TAMPONI PULITORI per SEDE MANDRINO

SPINDLE SEAT TAPER CLEANERS

SEDE mandrino ISO
ISO spindle SEAT



ISO	Art.
TP - ISO 30	4407
TP - ISO 40	4408
TP - ISO 45	4409
TP - ISO 50	4410

SEDE mandrino Cono Morse
Morse Taper spindle SEAT



CONO MORSE	Art.
TP - CM. 1	4411
TP - CM. 2	4412
TP - CM. 3	4413
TP - CM. 4	4414
TP - CM. 5	4415
TP - CM. 6	5065

SEDE mandrino HSK
HSK spindle SEAT



HSK	Art.
TP - HSK 32 A/C/E	5205
TP - HSK 40 A/C/E	5206
TP - HSK 50 A/C/E	5207
TP - HSK 63 A/C/E	5208
TP - HSK 80 A/C/E	5209
TP - HSK100 A/C/E	5210

TP - ER

TAMPONI PULITORI per SEDE PINZA ER

ER COLLET SEAT TAPER CLEANERS

SEDE pinza ER
ER collet SEAT



SEDE PINZA ER	Art.
TP - ER 16	5375
TP - ER 20	5376
TP - ER 25	5377
TP - ER 32	5378
TP - ER 40	5379

SUPPORTI

MAGAZZINI PORTACONI
TOOL STORES

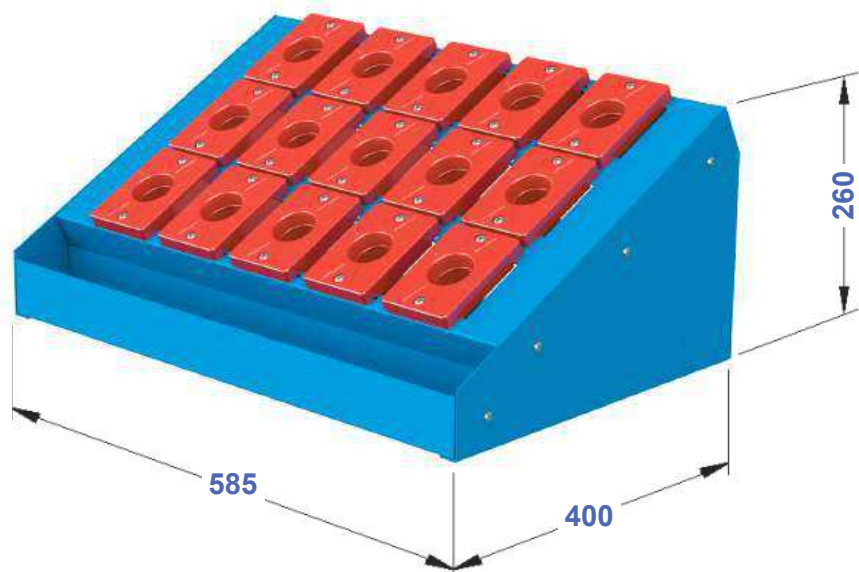

Forniti completi di boccole rosse

Supplied complete of red tool holder bushings



TIPO	Art.	N° SEDI		
MAG. ISO 30	3700	15	4416	0033
MAG. ISO 40	3701	15	4417	
MAG. ISO 45	3702	15	4418	
MAG. ISO 50	3703	12	4419	
MAG. HSK 32 A-C-E	9460	15	9440	0033
MAG. HSK 40 A-C-E	9461	15	9441	
MAG. HSK 50 A-C-E	3750	15	4430	
MAG. HSK 63 A-C-E	3751	15	4431	
MAG. HSK 80 A-C	9462	12	9442	
MAG. HSK100 A-C	3875	12	5543	0033
MAG. HSK 50 F	9461	15	9441	
MAG. HSK 63 F	3750	15	4430	
MAG. HSK 80 F	3751	15	4431	
MAG. POLIGONALE C 32	9463	15	9443	0033
MAG. POLIGONALE C 40	9464	15	9444	
MAG. POLIGONALE C 50	9465	15	9445	
MAG. POLIGONALE C 63	9466	15	9446	
MAG. POLIGONALE C 80	9467	12	9447	
MAG. CM 2	9468	15	9448	0033
MAG. CM 3	9469	15	9449	
MAG. CM 4	3696	15	4400	
MAG. CM 5	3702	15	4418	
MAG. Ø 32 - VDI 30	3705	15	5531	0033
MAG. Ø 40 - VDI 40	3706	15	5532	
MAG. Ø 50 - VDI 50	5557	12	5533	



su richiesta fornibili con boccole gialle
upon request with yellow tool holder bushing

UNITA' DA BANCO
BENCH UNITIES

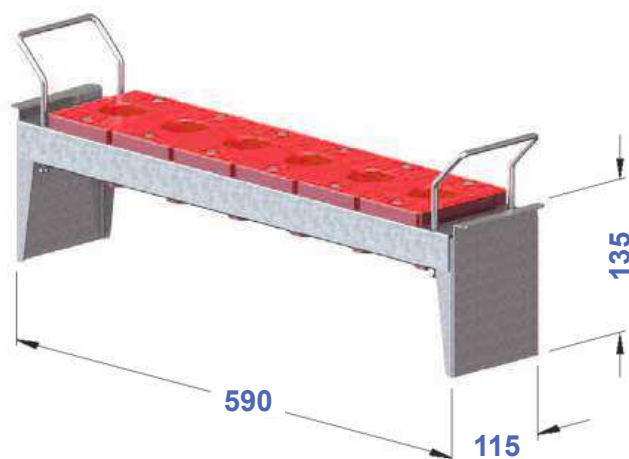

Fornite complete di boccole rosse

Supplied complete of red tool holder bushings



TIPO	Art.	N° SEDI	
UNITÀ ISO 30	4404	6	4416
UNITÀ ISO 40	4405	6	4417
UNITÀ ISO 45	4330	6	4418
UNITÀ ISO 50	4406	5	4419

UNITÀ HSK 32 A-C-E	9450	6	9440
UNITÀ HSK 40 A-C-E	9451	6	9441
UNITÀ HSK 50 A-C-E	4428	6	4430
UNITÀ HSK 63 A-C-E	4429	6	4431
UNITÀ HSK 80 A-C	9452	5	9442
UNITÀ HSK100 A-C	4794	5	5543
UNITÀ HSK 50 F	9451	6	9441
UNITÀ HSK 63 F	4428	6	4430
UNITÀ HSK 80 F	4429	6	4431

UNITÀ POLIGONALE C 32	9453	6	9443
UNITÀ POLIGONALE C 40	9454	6	9444
UNITÀ POLIGONALE C 50	9455	6	9445
UNITÀ POLIGONALE C 63	9456	6	9446
UNITÀ POLIGONALE C 80	9457	5	9447

UNITÀ CM 2	9458	6	9448
UNITÀ CM 3	9459	6	9449
UNITÀ CM 4	4329	6	4400
UNITÀ CM 5	4330	6	4418

UNITÀ Ø 32 - VDI 30	5369	5	5531
UNITÀ Ø 40 - VDI 40	5370	5	5532
UNITÀ Ø 50 - VDI 50	5371	4	5533



su richiesta fornibili con boccole gialle
upon request with yellow tool holder bushings

BOCCOLE
TOOL HOLDER BUSHINGS



TIPO	Art.	
BOCCOLA ISO 30	4416	0033
BOCCOLA ISO 40	4417	
BOCCOLA ISO 45	4418	
BOCCOLA ISO 50	4419	

BOCCOLA HSK 32 A-C-E	9440	0033
BOCCOLA HSK 40 A-C-E	9441	
BOCCOLA HSK 50 A-C-E	4430	
BOCCOLA HSK 63 A-C-E	4431	
BOCCOLA HSK 80 A-C	9442	
BOCCOLA HSK100 A-C	5543	
BOCCOLA HSK 50 F	9441	0033
BOCCOLA HSK 63 F	4430	
BOCCOLA HSK 80 F	4431	

BOCCOLA POLIGONALE C 32	9443	0033
BOCCOLA POLIGONALE C 40	9444	
BOCCOLA POLIGONALE C 50	9445	
BOCCOLA POLIGONALE C 63	9446	
BOCCOLA POLIGONALE C 80	9447	

BOCCOLA CM 2	9448	0033
BOCCOLA CM 3	9449	
BOCCOLA CM 4	4400	
BOCCOLA CM 5	4418	

BOCCOLA Ø 32 - VDI 30	5531	0033
BOCCOLA Ø 40 - VDI 40	5532	
BOCCOLA Ø 50 - VDI 50	5533	



su richiesta fornibili boccole di colore giallo
upon request yellow tool holder bushings

INDICE DEGLI STRUMENTI
INDEX OF INSTRUMENTS

AZZERATORI MAGNETICI

- **LUMINOSO**

- **con COMPARATORE**

ELECTRONIC EDGE FINDER

- BRIGHT

- with COMPARATOR

pag. 247



CENTRATORI MECCANICI

con stelo RETTIFICATO

GRINDED STEM

MECHANICAL EDGE FINDERS

pag. 248



CENTRATORI MECCANICI

con stelo BRUNITO

BROWNED STEM

MECHANICAL EDGE FINDERS

pag. 248



CENTRATORI MECCANICI

ANTIMAGNETICI

ANTIMAGNETIC

MECHANICAL EDGE FINDERS

pag. 249



CENTRATORI MECCANICI

ANTIMAGNETICI

con TESTINA CERAMICA

ANTIMAGNETIC FLOATING EDGE

FINDER HEARTHENWARE HEAD

pag. 249



CENTRATORI a SFERA

- **LUMINOSO**

- **LUMINOSO e SONORO**

ELECTRONIC EDGE FINDER

- BRIGHT

- BRIGHT and SONOROUS

pag. 250



CENTRATORI 3D

- **LUMINOSO e SONORO**

- **con COMPARATORE**

ELECTRONIC EDGE FINDER

- BRIGHT and SONOROUS

- with COMPARATOR

pag. 250 - 251



pag. 251

**STRUMENTI
ZOP**

AZZERATORE MAGNETICO LUMINOSO
BRIGHT MAGNETIC RESETTER

BATTERY



TIPO	Art.	
ZOP 50	0351	0266

- base magnetica permanente
- permanent magnetic base

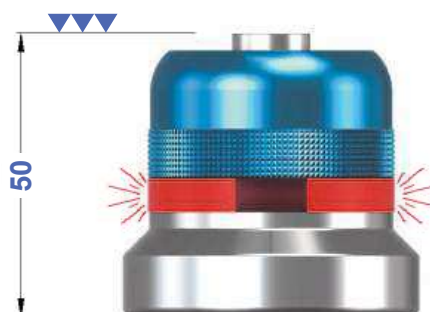

**STRUMENTI
ZDI**

AZZERATORI MAGNETICI CON COMPARATORE
BUILD-IN MAGNETIC RESETTERS WITH COMPARATOR

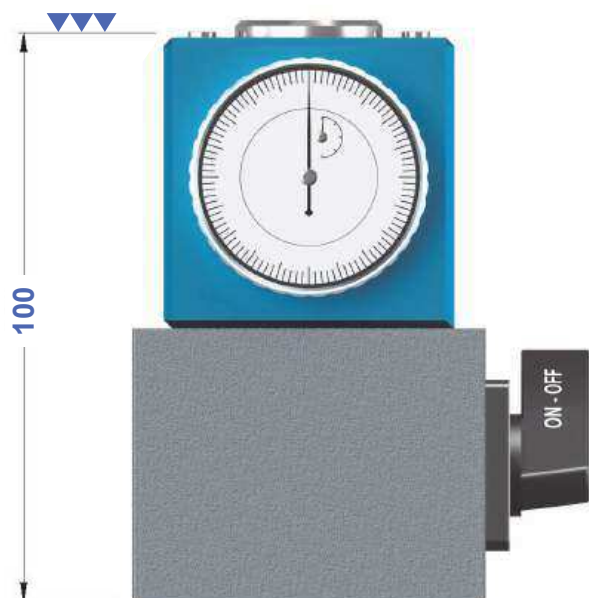
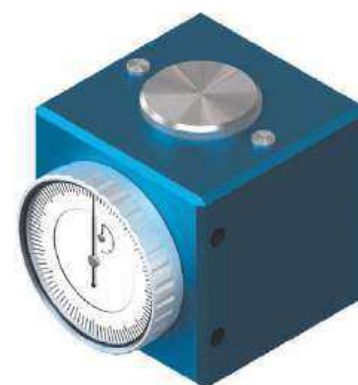

TIPO	Art.
ZDI 100	0354

- base magnetica comandata ON/OFF
- comparatore ø40 con lettura 0,01
- switch ON/OFF magnetic base
- dial gauge ø40 reading 0,01

TIPO	Art.
ZDI 50	0349

- base magnetica permanente
- comparatore ø40 con lettura 0,01
- permanent magnetic base
- dial gauge ø40 reading 0,01

**STRUMENTI
CMP**

CENTRATORI MECCANICI FLOTTANTI CON STELO RETTIFICATO

FLOATING EDGE FINDERS WITH GRINDED STEM

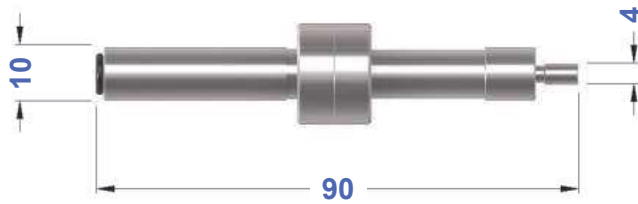

TIPO	Art.	
CMP 10 - 4	0356	0333

Nella confezione dei CMP è compresa una molla di ricambio
In CMP wrapping is included one spare spring

TIPO	Art.	
CMP 10 - 10	0357	0333

max 600 rpm

**STRUMENTI
CMB**

CENTRATORI MECCANICI FLOTTANTI CON STELO BRUNITO

FLOATING EDGE FINDERS WITH BROWNEDED STEM



TIPO	Art.	
CMB 10 - 4	0242	0333

Nella confezione dei CMB è compresa una molla di ricambio
In CMB wrapping is included one spare spring

TIPO	Art.	
CMB 10 - 10	0243	0333

max 600 rpm

MOLLE

MOLLE PER CENTRATORI MECCANICI FLOTTANTI

SPRINGS FOR MECHANICAL FLOATING EDGE FINDERS

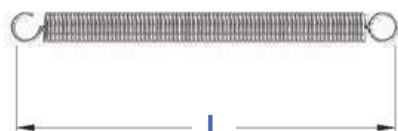

L	Art.
50	0333
* 55	0363

* Consigliata per centratori privi di spina di bloccaggio molla
Recommended for edge finders without spring locking pin

**STRUMENTI
CMA**

CENTRATORI MECCANICI FLOTTANTI ANTIMAGNETICI
ANTIMAGNETIC FLOATING EDGE FINDERS

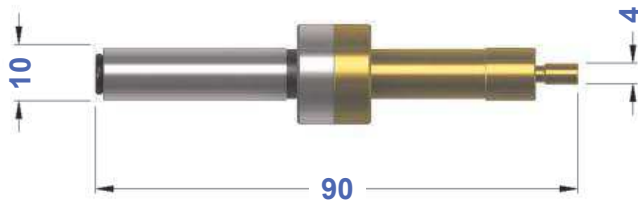

TIPO	Art.	
CMA 10 - 4	0445	0333

Nella confezione dei CMA è compresa una molla di ricambio
In CMA wrapping is included one spare spring

TIPO	Art.	
CMA 10 - 10	0447	0333

max 600 rpm

**STRUMENTI
CMD**

**CENTRATORE MECCANICO FLOTTANTE ANTIMAGNETICO
CON TESTINA CERAMICA**

ANTIMAGNETIC FLOATING EDGE FINDER WITH EARTHENWARE HEAD



TIPO	Art.	
CMD 10 - 10	0455	0333

max 600 rpm

**STRUMENTI
CMC**

**CENTRATORE MECCANICO FLOTTANTE ANTIMAGNETICO
SOTTILE CON TESTINA CERAMICA**
SLIM ANTIMAGNETIC FLOATING EDGE FINDER WITH EARTHENWARE HEAD



TIPO	Art.	
CMC 10 - 10	0457	0458

max 600 rpm

**STRUMENTI
CSL**

CENTRATORI A SFERA LUMINOSI
BRIGHT ELECTRONIC EDGE FINDERS

BATTERY



TIPO	Art.	L	
CSL 100	0335	100	0266
CSL 120	0355	120	0562
CSL 160	0358	160	0562

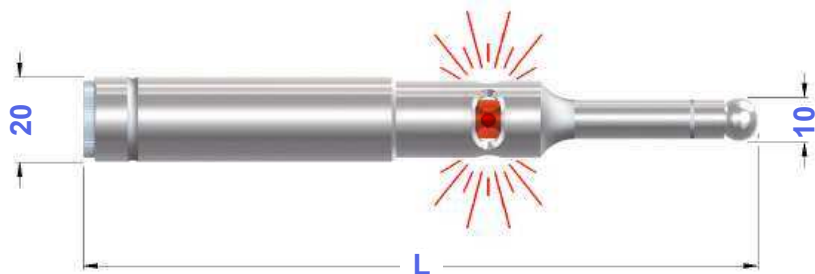

**STRUMENTI
CSS**

CENTRATORE A SFERA LUMINOSO E SONORO
BRIGHT-SONOROUS ELECTRONIC EDGE FINDER

BATTERY



TIPO	Art.	L	
CSS 160	0359	160	0562

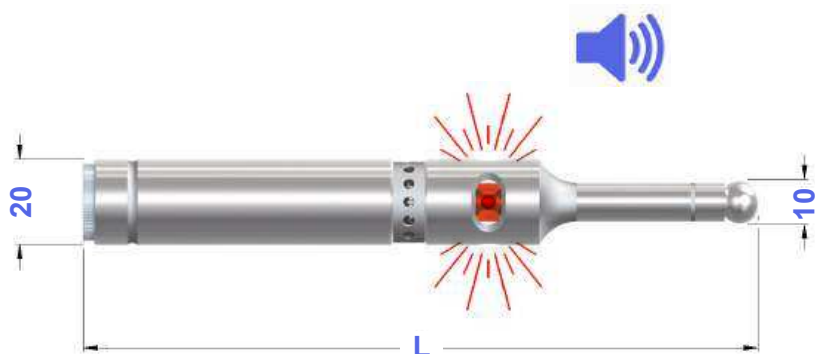

**STRUMENTI
CTL**

CENTRATORE 3D LUMINOSO E SONORO
BRIGHT-SONOROUS 3D ELECTRONIC EDGE FINDER

TASTER

LED

BATTERY

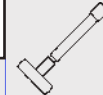

TIPO	Art.			
CTL 20 - 6	0350	0322	0328	0595





STRUMENTI

TASTATORI TRIDIMENSIONALI CON COMPARATORE
TRIDIMENSIONAL POSITION DETECTORS WITH COMPARATOR

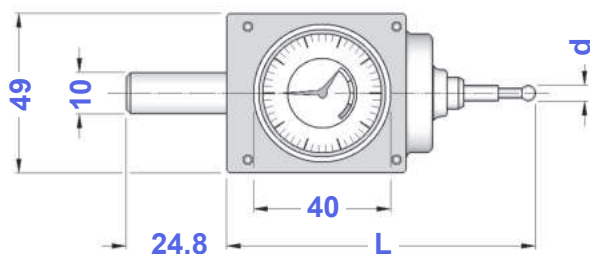

ATTACCO D.10
D.10 SHANK



TIPO	Art.	d	L	
CTZ 10 - 04	0541	4	96	0619
CTZ 10 - 08	0542	8	136	0629



ATTACCO D.12
D.12 SHANK

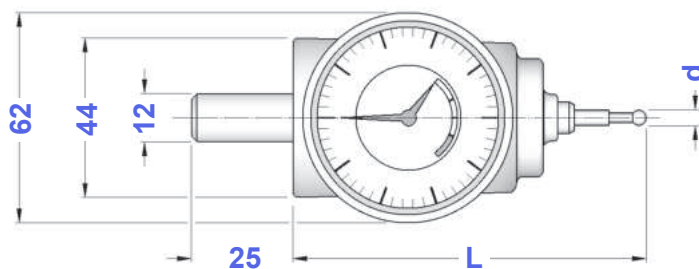

TIPO	Art.	d	L	
CTN 12 - 04	0543	4	100	0619
CTN 12 - 08	0544	8	140	0629



ATTACCO D.20
D.20 SHANK

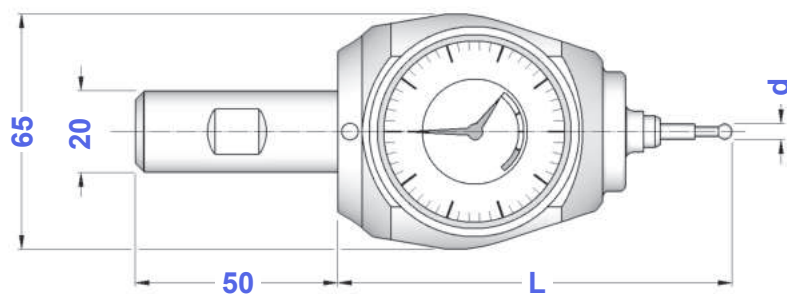

TIPO	Art.	d	L	
CTA 20 - 04	0584	4	113	0619
CTA 20 - 08	0585	8	153	0629

ASTINE CERAMICHE
EARTHENWARE TASTERS

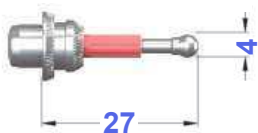

TIPO	Art.
ASTINA CORTA d. 4	0619
ASTINA LUNGA d. 8	0629

UGELLI A SFERA
SPHERE COOLANT NOZZLES

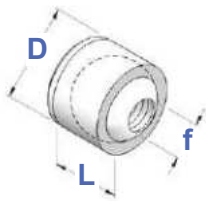

Art.	D	L	f
9200	6	5	M 2,5
9201	8	6	M 4
9202	10	7	M 5
9203	12	8	M 5
9204	12	8	M 6
9205	14	9	M 8
9206	16	10	M 10x1



PROLUNGHE PER UGELLI
EXTENSIONS FOR COOLANT NOZZLES

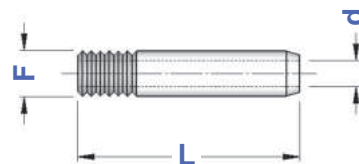

Art.	F	d	L
9210	M 3	1,5	25
9211	M 4	1	30
9212	M 4	2	30
9213	M 5	2	30
9214	M 5	3	40
9215	M 6	2	35
9216	M 6	3	35
9217	M 6	4	50
9218	M 8	2	40
9219	M 8	3	40
9220	M 8	4	40
9221	M 8	5	50
9222	M10x1	2	40
9223	M10x1	4	40
9224	M10x1	6	50
9225	M10x1	8	50

UGELLI A SFERA PER ALTA PRESSIONE
SPHERE COOLANT NOZZLES FOR HIGH PRESSURE

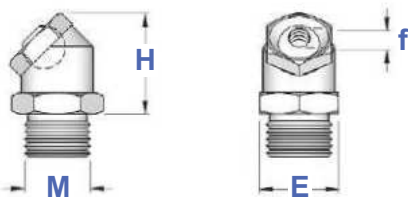

Art.	f	E	M	H
9235	M 3	16	1/8	19
9236	M 5	18	1/4	21
9237	M 6	20	3/8	23
9238	M 8	23	3/8	27



UGELLI PER ALTA PRESSIONE ORIENTABILI
ORIENTABLE COOLANT NOZZLES FOR HIGH PRESSURE

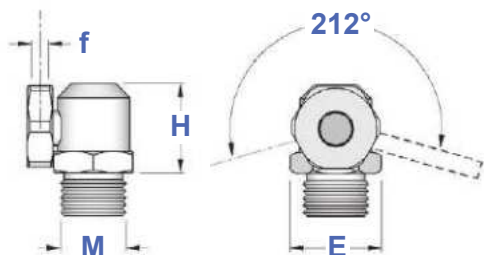

Art.	f	E	M	H
9240	M 4	12	1/8	17
9241	M 5	14	1/8	18
9242	M 6	17	1/4	21



PROLUNGHE PER UGELLI A 45°
45° EXTENSIONS FOR COOLANT NOZZLES

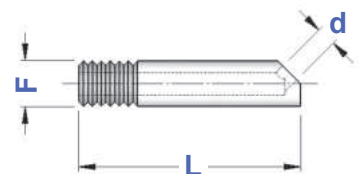

Art.	F	d	L
9230	M 5	2,5	23
9231	M 6	3	30
9232	M 8	4	35

AD

**ANELLI DISTANZIATORI
SPACERS**

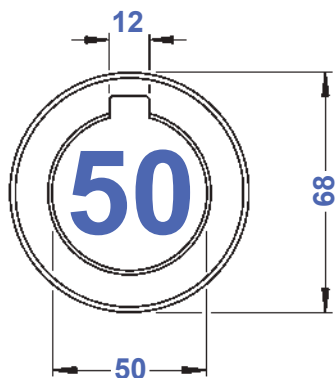
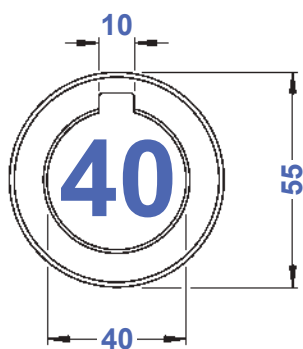
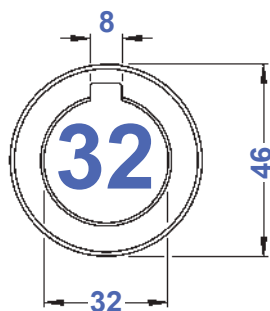
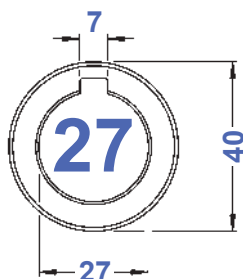
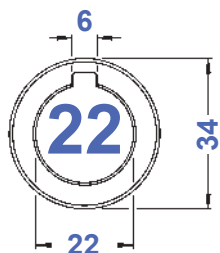
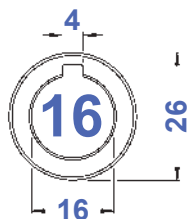

TIPO	Art.	Spessori - Thickness
AD - D.16	4084	0,03 - 0,04 - 0,05 - 0,06 0,1 - 0,2 - 0,3 - 0,4 - 0,5 - 0,6 1,0 - 2,0 - 3,0 - 4,0 - 5,0 - 6,0 10,0 - 20,0 - 30,0
AD - D.22	4085	0,03 - 0,04 - 0,05 - 0,06 0,1 - 0,2 - 0,3 - 0,4 - 0,5 - 0,6 1,0 - 2,0 - 3,0 - 4,0 - 5,0 - 6,0 10,0 - 20,0 - 30,0 - 60,0 - 100,0
AD - D.27	4086	0,03 - 0,04 - 0,05 - 0,06 0,1 - 0,2 - 0,3 - 0,4 - 0,5 - 0,6 1,0 - 2,0 - 3,0 - 4,0 - 5,0 - 6,0 10,0 - 20,0 - 30,0 - 60,0 - 100,0
AD - D.32	4087	0,03 - 0,04 - 0,05 - 0,06 0,1 - 0,2 - 0,3 - 0,4 - 0,5 - 0,6 1,0 - 2,0 - 3,0 - 4,0 - 5,0 - 6,0 10,0 - 20,0 - 30,0 - 60,0 - 100,0
AD - D.40	4088	0,03 - 0,04 - 0,05 - 0,06 0,1 - 0,2 - 0,3 - 0,4 - 0,5 - 0,6 1,0 - 2,0 - 3,0 - 4,0 - 5,0 - 6,0 10,0 - 20,0 - 30,0 - 60,0 - 100,0
AD - D.50	4089	0,05 - 0,06 0,1 - 0,2 - 0,3 - 0,4 - 0,5 - 0,6 1,0 - 2,0 - 3,0 - 4,0 - 5,0 - 6,0 10,0 - 20,0 - 30,0 - 60,0 - 100,0

VTC

VITI DI FISSAGGIO FRESA CON TESTA A CROCE

MILL LOCKING CROSS HEAD SCREWS

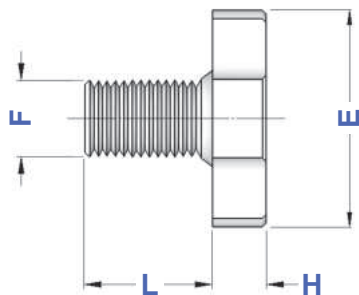

TIPO	Art.	F	E	L	H	
VTC 16	4985	M 8	20	16	6	4562
VTC 22	4986	M10	28	18	7	4563
VTC 27	4987	M12	35	22	8	4564
VTC 32	4988	M16	42	26	9	4565
VTC 40	4989	M20	52	30	10	4566
VTC 50	4990	M24	63	36	12	4567



CON PASSAGGIO DEL REFRIGERANTE

WITH COOLANT THROUGH

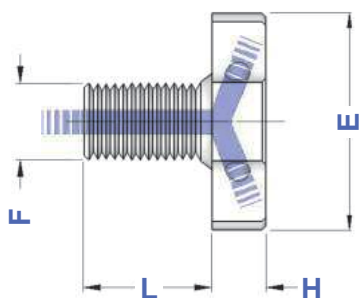

TIPO	Art.	F	E	L	H	
VPR 16	2739	M 8	20	16	6	4562
VPR 22	2740	M10	28	18	7	4563
VPR 27	2741	M12	35	22	8	4564
VPR 32	2742	M16	42	26	9	4565
VPR 40	2743	M20	52	30	10	4566



CH-VTC

CHIAVI PER VITI TESTA A CROCE

WRENCHES FOR CROSS HEAD SCREWS



TIPO	Art.	
CH 16 VTC	4562	4985
CH 22 VTC	4563	4986
CH 27 VTC	4564	4987
CH 32 VTC	4565	4988
CH 40 VTC	4566	4989
CH 50 VTC	4567	4990



TPF

TASSELLI PER PORTAFRESE FISSI DOWELS FOR FACE MILL HOLDERS



Figura 1



Figura 2



TIPO	Art.	H	L	A	Fig.	
TPF - D. 13	7433*	6,5	8,0	13,0	1	0201
TPF - D. 16	7434	7,0	8,0	13,0	1	0201
	7421	10,5	8,0	13,0	1	0255
TPF - D. 22	7435	8,0	10,0	15,6	1	0203
	7070*	10,0	10,0	18,0	1	0256
	7427	11,6	10,0	15,6	1	0256
TPF - D. 27	7436	9,0	12,0	18,3	1	0205
	7071*	12,0	12,0	18,0	1	7414
TPF - D. 32	7428	13,3	12,0	18,3	1	7414
	7437	11,0	14,0	21,0	1	0482
	7072*	14,0	14,0	22,0	1	0099
	7439	15,0	14,0	21,0	1	0099
TPF - D. 40	7429	20,5	14,0	21,0	1	0099
	7438	13,0	16,0	24,0	1	0207
	0210	16,0	15,9	15,5	2	0207
	7073*	16,0	15,9	19,5	2	0207
TPF - D. 60	7430	22,5	16,0	24,0	1	0099
	0211	25,0	25,4	28,0	2	0407

* Tasselli per esecuzioni speciali / Dowels for special executions

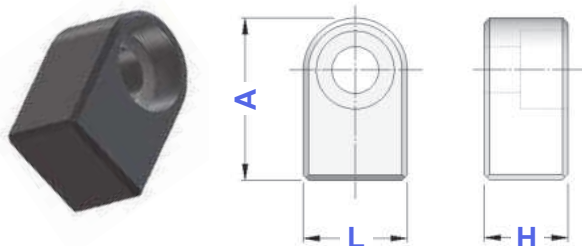
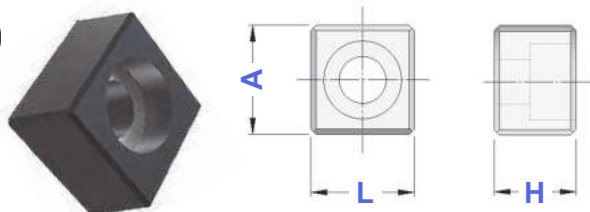
AT

GIUNTI DI TRASCINAMENTO PER PORTAFRESE COMBINATI CLUTCH DRIVE RINGS FOR DIN 6358 COMBI SHELL MILL HOLDERS

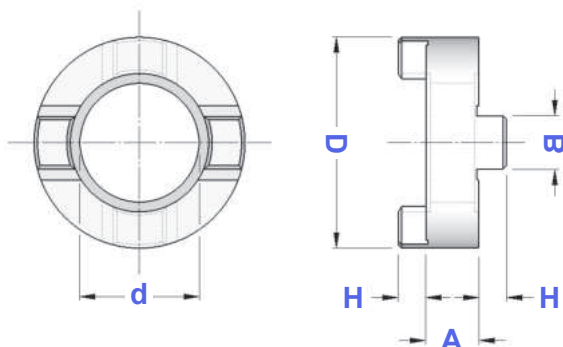

TIPO	Art.	d	D	H	A	B
AT 16	4090	16	32	5,0	10	8
AT 22	4091	22	40	5,6	12	10
AT 27	4092	27	48	6,3	12	12
AT 32	4093	32	58	7,0	14	14
AT 40	4094	40	70	8,0	14	16
AT 50	4095	50	90	9,0	16	18

CHIAVETTE

CHIAVETTE KEYS



Art.	A	H	L
0103	3	3	10
0041	4	4	12
0115	4	4	20
0147	4	4	22
0258	5	4	18
0107	5	4	20
0044	6	6	15
0108	6	6	20
0116	6	6	25
0148	6	6	32

Art.	A	H	L
0045	7	7	16
0122	7	7	25
0149	7	7	50
0047	8	7	16
0111	8	7	25
0125	8	7	28
0150	8	7	50
0114	10	8	30
0133	10	8	32
0151	10	8	50
0137	12	8	36
0152	12	8	50

segue
continue

RICAMBI PER RIDUZIONI A CONO MORSE PER FRESE
 SPARES FOR MT ADAPTERS FOR MILLING CUTTERS DIN 228 FORM A SHANK

TIRANTI PER FRESA
 TIE RODS FOR MILL

TIPO	Art.	F	L	D	H	E	Passo
CM 2	7056*	M10	30	12,9	6,5	7	1,5
	7448	M10	30	13,0	10,0	8	1,5
CM 3	7057*	M12	30	18,0	7,0	8	1,75
	7402	M12	35	17,0	12,0	8	1,75
	7403	M12	35	18,0	12,0	10	1,75
	7058*	M12	40	18,0	7,0	8	1,75
CM 4	7404	M16	40	20,0	16,0	10	2
	7407	M16	40	21,5	16,0	14	2
	7411	M16	45	21,5	9,0	12	2
	7067*	M16	45	23,0	9,0	12	2
CM 5	7069*	M20	50	30,0	11,0	14	2,5
	7408*	M20	55	30,0	20,0	17	2,5

* Tiranti per esecuzioni speciali / Tie rods for special executions

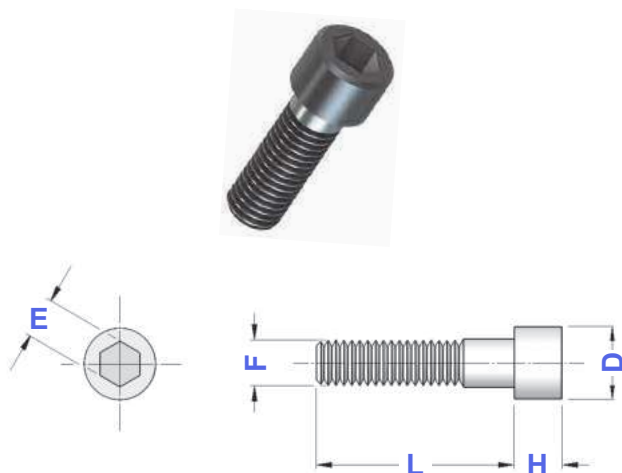

GHIERE SINISTRE PER TIRANTI
 LEFT NUTS FOR TIE RODS

Chiave
Wrench

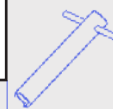

Art.	CM	F	H	
7422	CM 2	M 15 x 1,5 SX	6,0	4569
7423	CM 3	M 20 x 1,5 SX	6,0	4570
7424	CM 4	M 24 x 1,5 SX	8,5	4571
7425	CM 5	M 36 x 2 SX	11,0	4572

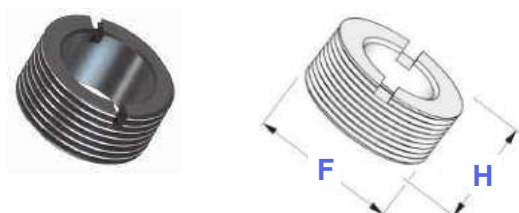

CHIAVI PER GHIERE SINISTRE
 WRENCHES FOR LEFT NUTS

Ghiera
Nut



Art.	CM	D	L	
4569	CM 2	14,8	110	7422
4570	CM 3	19,2	115	7423
4571	CM 4	23,0	140	7424
4572	CM 5	37,0	172	7425

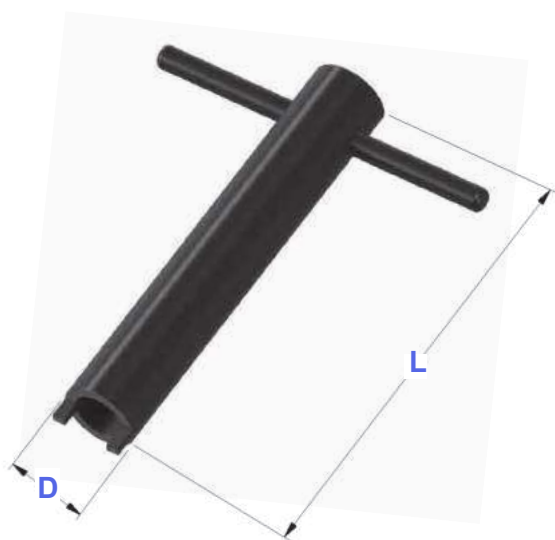

RICAMBI PER RIDUZIONI A CONO MORSE COMBinate PUNTE + FRESE

SPARES FOR COMBI MT ADAPTERS: TWIST DRILLS + MILLING CUTTERS

TIRANTI PER FRESA

TIE RODS FOR MILL

TIPO	Art.	F	L	D	H	E	Passo
CM 1	7400	M 6	35	10,0	6,0	5	1
	7046*	M 6	45	10,0	6,0	5	1
	0035	M 6	55	10,0	6,0	5	1
	7047*	M 6	75	10,0	6,0	5	1
CM 2	7048*	M10	40	12,9	6,5	8	1,5
	7049*	M10	40	16,0	10,0	8	1,5
	7401	M10	45	13,5	10,0	8	1,5
	7050*	M10	45	16,0	6,5	7	1,5
	7405	M10	45	16,0	10,0	8	1,5
	7051*	M10	60	13,5	10,0	8	1,5
	7052*	M10	60	16,0	10,0	8	1,5
	0038	M10	70	16,0	10,0	8	1,5
CM 3	0177	M12	50	18,0	12,0	10	1,75
	7455	M12	55	17,0	12,0	10	1,75
	7406	M12	55	18,0	12,0	10	1,75
	0040	M12	70	18,0	12,0	10	1,75
CM 4	7409	M16	60	20,5	16,0	14	2
	0042	M16	80	20,5	16,0	14	2

* Tiranti per esecuzioni speciali / Tie rods for special executions

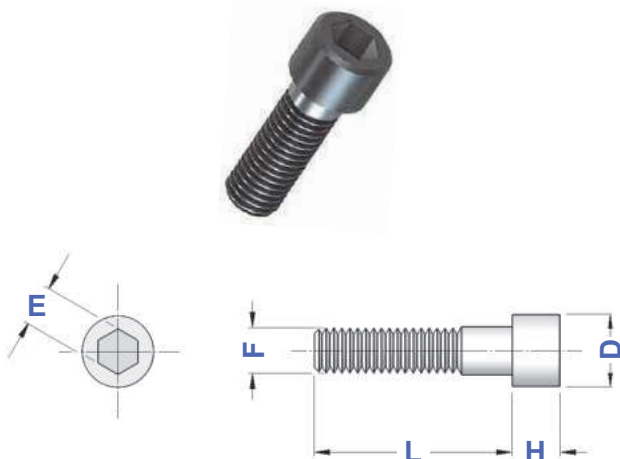

TIRANTI DA USARE CON RIDUTTORE

TIE RODS TO BE USED WITH REDUCER

Riduttore
Reducer



TIPO	Art.	F	L	D	H	E	Passo	
CM 3	7400	M 6	35	10,0	6,0	5	1	0130
	7046*	M 6	45	10,0	6,0	5	1	0130
	0035	M 6	55	10,0	6,0	5	1	0130
	7054*	M 6	60	10,0	6,0	5	1	0130
CM 4	0056	M10	50	16,0	10,0	8	1,5	0129
CM 5	0055	M12	85	18,0	12,0	10	1,75	0131

* Tiranti per esecuzioni speciali / Tie rods for special executions

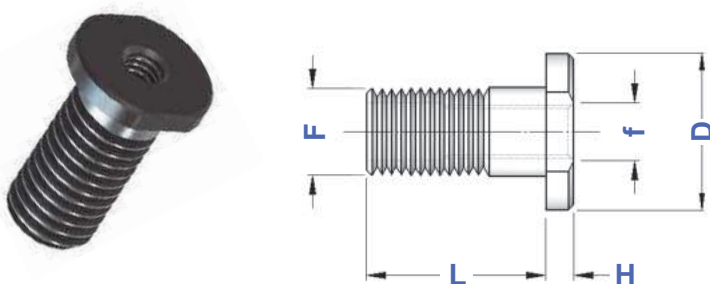

RIDUTTORI PER TIRANTI

REDUCERS FOR TIE RODS

TIPO	Art.	F	f	L	H	D
CM 2	0276	M 10	M 6	19	3	14
CM 3	0130	M 12	M 6	25	3	19
CM 4	0129	M 16	M 10	27	3	25
CM 5	0131	M 20	M 12	37	6	35

VITI

VITI A TESTA CILINDRICA
ROUND HEAD SCREWS

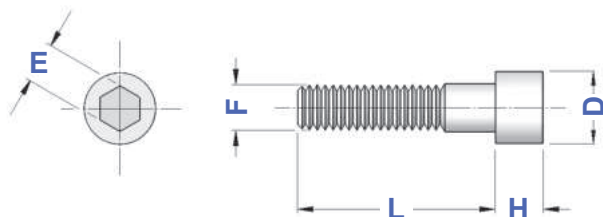

Art.	F	L	D	H	E	Passo
0201	M 3	8	5,5	3	2,5	0,5
0255	M 3	10	5,5	3	2,5	0,5
0203	M 4	10	7,0	4	3	0,7
0256	M 4	12	7,0	4	3	0,7
0205	M 5	12	8,5	5	4	0,8
7414	M 5	18	8,5	5	4	0,8
0484	M 6	10	10,0	6	5	1
0482	M 6	12	10,0	6	5	1
0206	M 6	14	10,0	6	5	1
0207	M 6	18	10,0	6	5	1
7447	M 6	20	8,5	4	4	1
0099	M 6	20	10,0	6	5	1
7415	M 6	25	10,0	6	5	1
0031	M 6	30	10,0	6	5	1
7400	M 6	35	10,0	6	5	1
7046	M 6	45	10,0	6	5	1
0035	M 6	55	10,0	6	5	1
7054	M 6	60	10,0	6	5	1
7047	M 6	75	10,0	6	5	1
0297	M 8	12	13,0	8	6	1,25
0491	M 8	16	13,0	8	6	1,25
0023	M 8	20	13,0	8	6	1,25
0586	M 8	30	10,0	8	6	1,25
0533	M 8	30	13,0	8	6	1,25

segue
continue ➔

Art.	F	L	D	H	E	Passo
7056	M10	30	12,9	6,5	7	1,5
7448	M10	30	13,0	10	8	1,5
0120	M10	30	16,0	10	8	1,5
7413	M10	35	16,0	10	8	1,5
7048	M10	40	12,9	6,5	8	1,5
7049	M10	40	16,0	10	8	1,5
7401	M10	45	13,5	10	8	1,5
7050	M10	45	16,0	6,5	7	1,5
7405	M10	45	16,0	10	8	1,5
0056	M10	50	16,0	10	8	1,5
7051	M10	60	13,5	10	8	1,5
7052	M10	60	16,0	10	8	1,5
0038	M10	70	16,0	10	8	1,5
7053	M10	90	16,0	10	8	1,5
0407	M12	25	18,0	12	10	1,75
7057	M12	30	18,0	7	8	1,75
7410	M12	30	18,0	12	10	1,75
7402	M12	35	17,0	12	8	1,75
7403	M12	35	18,0	12	10	1,75
7058	M12	40	18,0	7	8	1,75
7416	M12	45	18,0	12	10	1,75
0177	M12	50	18,0	12	10	1,75
7455	M12	55	17,0	12	10	1,75
7406	M12	55	18,0	12	10	1,75
0040	M12	70	18,0	12	10	1,75
0055	M12	85	18,0	12	10	1,75
7404	M16	40	20,0	16	10	2
7407	M16	40	21,5	16	14	2
7450	M16	40	24,0	16	14	2
7411	M16	45	21,5	9	12	2
7067	M16	45	23,0	9	12	2
7409	M16	60	20,5	16	14	2
0179	M16	60	21,5	9	12	2
7451	M16	60	24,0	16	14	2
0042	M16	80	20,5	16	14	2
7069	M20	50	30,0	11	14	2,5
7408	M20	55	30,0	20	17	2,5
7417	M24	60	36,0	13	17	3
0254	M24	90	36,0	13	17	3

G - WE

GRANI DI FISSAGGIO PER MANDRINI WELDON

LOCKING SCREWS FOR END MILL HOLDERS

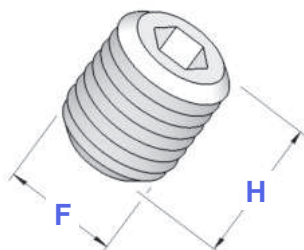

TIPO	Art.	F x H	Passo
G - WE 6	4970	M 6 x 10	1
G - WE 8	4971	M 8 x 10	1,25
G - WE 10	4972	M 10 x 12	1,5
G - WE 12	4973	M 12 x 16	1,75
G - WE 14	4973	M 12 x 16	1,75
G - WE 16	4974	M 14 x 16	2
G - WE 18	4974	M 14 x 16	2
G - WE 20	4975	M 16 x 16	2
G - WE 25	4976	M 18 x 2 x 20	2
G - WE 32	4977	M 20 x 2 x 20	2
G - WE 40	4977	M 20 x 2 x 20	2
G - WE 50	4978	M 24 x 2 x 20	2

GRANI

GRANI DI REGOLAZIONE E DI FISSAGGIO

SETTING AND LOCKING SCREWS

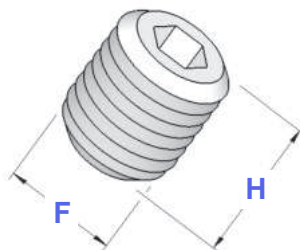

Art.	F x H	Passo
0011	M 4 x 4	0,7
0380	M 4 x 8	0,7
0173	M 4 x 14	0,7
0017	M 5 x 4	0,8
0019	M 5 x 5	0,8
0365	M 5 x 6	0,8
0366	M 5 x 10	0,8
0285	M 5 x 30	0,8
0388	M 5 x 40	0,8
0367	M 6 x 4	1
0368	M 6 x 5	1
0020	M 6 x 6	1
0370	M 6 x 8	1
4970	M 6 x 10	1
0371	M 6 x 12	1
0181	M 6 x 14	1
0208	M 6 x 16	1
0253	M 6 x 40	1
0372	M 8 x 6	1,25
0021	M 8 x 8	1,25
4971	M 8 x 10	1,25
0375	M 8 x 12	1,25
0382	M 8 x 16	1,25
0183	M 8 x 20	1,25
0284	M 8 x 40	1,25
0409	M 10 x 1 x 10	1
0403	M 10 x 1 x 12	1
0385	M 10 x 8	1,5
0060	M 10 x 10	1,5
4972	M 10 x 12	1,5

Art.	F x H	Passo
0377	M 10 x 16	1,5
0186	M 10 x 20	1,5
0417	M 12 x 1 x 12	1
0200	M 12 x 10	1,75
0260	M 12 x 12	1,75
0390	M 12 x 14	1,75
4973	M 12 x 16	1,75
0188	M 12 x 30	1,75
0074	M 14 x 1 x 6	1
0401	M 14 x 1,5 x 16	1,5
0082	M 14 x 10	2
0261	M 14 x 12	2
0068	M 14 x 14	2
4974	M 14 x 16	2
0493	M 16 x 1 x 12	1
0420	M 16 x 1 x 16	1
0404	M 16 x 1,5 x 12	1,5
0073	M 16 x 10	2
0070	M 16 x 12	2
0400	M 16 x 14	2
4975	M 16 x 16	2
0076	M 18 x 2 x 12	2
0075	M 18 x 2 x 17	2
4976	M 18 x 2 x 20	2
0259	M 20 x 2 x 17	2
4977	M 20 x 2 x 20	2
4978	M 24 x 2 x 20	2

segue
continue M10 ➡

➔ segue altri grani
continue other grain

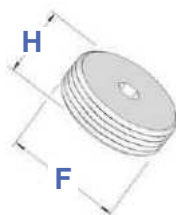

CON FORO PASSANTE
WITH THROUGH HOLE

Art.	F x H	Passo
0190	M18 x1,5 x 8	1,5
0191	M22 x1,5 x 8	1,5
0195	M27 x1,5 x 8	1,5

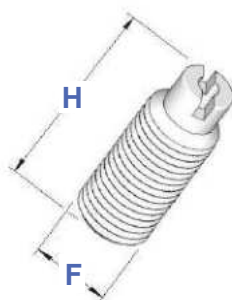

CON FORO PASSANTE
WITH THROUGH HOLE

Art.	F x H	Passo
0233	M 5 x16	0,8
0235	M 6 x16	1
0238	M 8 x20	1,25
0240	M10 x25	1,5
0245	M12 x30	1,75
1226	M16 x20	2
0212	M20 x20	2,5
0247	M20 x30	2,5

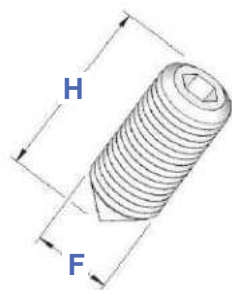

PUNTA CONICA
TAPER TIP

Art.	F x H	Passo
0510	M 4 x 4	0,7
0015	M 4 x14	0,7
0513	M 5 x 5	0,8
0529	M 5 x 6	0,8
0016	M 5 x10	0,8
0036	M 5 x16	0,8
0531	M 6 x 6	1
0557	M 6 x10	1
0037	M 8 x 8	1,25

Viti Testa Quadra da M5 a M8 pag. 365
Square headed screws from M5 to M5



Senza Collare
Without Collar



Con Collare
With Collar

Chiavi per Viti Testa Quadra pag. 365
Wrenches for Square headed screws



Chiave a "Pipa"
"Pipe" type Wrench

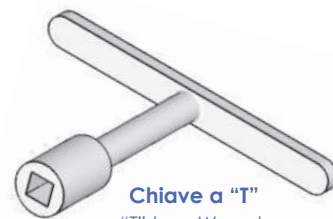

Chiave a "T"
"T" type Wrench

APPARECCHI PNEUMATICI CHIUDIPINZA
PNEUMATIC COLLET CHUCKS

Pinza - Collet



Art.	PRESA - CLAMP			L	D	H	S	d	B	KN 6 bar	KN 8 bar	KN 10 bar	Art.	Einheits
	∅ max	∅ max	∅ max											
2224	26	24	20	170	152	77	97	74	28	5	7	9	0701	161E
2226	42	38	30	180	165	85	117	92	32	6	8	10	0709	173E

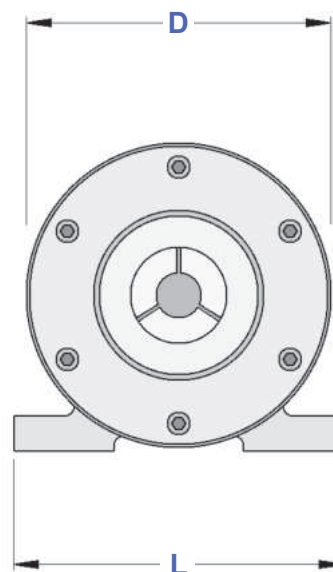
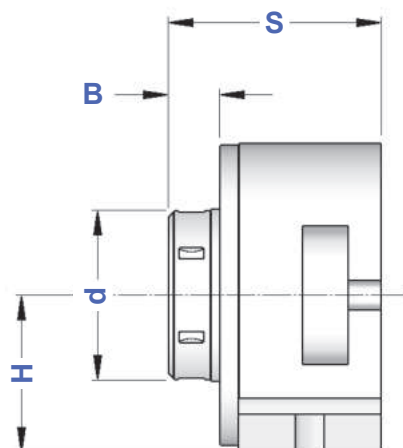

Pinze a pag. 277



Collets at page 277

INDICE DELLE PINZE

INDEX OF COLLETS

PINZE **ER**
ER COLLETS



pag. 11

PINZE **ER - HP**
ER - HP COLLETS



pag. 16

PINZE **ER - JET**
ER - JET COLLETS



pag. 17

PINZE **ER - RF**
ER - RF COLLETS



pag. 18

PINZE **ER - UP**
ER - UP COLLETS



pag. 19

PINZE **ER SSC**
ER SSC COLLETS



pag. 20

PINZE **ER SSC - HP**
ER SSC - HP COLLETS



pag. 21

PINZE **ER - MF**
ER - MF COLLETS



pag. 22

PINZE **ER - ML**
ER - ML COLLETS



pag. 23

PINZE **ER - AM**
ER - AM COLLETS



pag. 24

PINZE **ETS**
ETS COLLETS



pag. 266

PINZE **EOC** - DIN 6388
EOC COLLETS (ISO 10897)



pag. 268

PINZE **PC**
PER FORTE SERRAGGIO
FOR HIGH GRIP CHUCKS



pag. 270

PINZE **PC - UP**
PER FORTE SERRAGGIO
UP FOR HIGH GRIP CHUCKS



pag. 271

PINZE **PH**
PER MANDRINI IDRAULICI
FOR HYDRAULIC CHUCKS



pag. 272

PINZE **CONO MORSE**
DIN 6328 - DIN 6329
MORSE TAPER COLLETS



pag. 273

PINZE **CONO MORSE**
con FILETTO
MORSE TAPER WITH THREAD



pag. 273

PINZE **DA**
DA COLLETS



pag. 274

PINZE **TG**
TG COLLETS



pag. 274

PINZE **BAKUER**
BAKUER COLLETS



pag. 275

INDICE DELLE PINZE

INDEX OF COLLETS

PINZE 443E
443E COLLETS



pag. 275

PINZE BRIDGEPORT R8
BRIDGEPORT R8 COLLETS



pag. 275

PINZE CONO SEMPLICE
SINGLE CONE COLLETS



da pag. 277

PINZE DOPPIO CONO
DOUBLE CONE COLLETS



pag. 278

TESTE DI CHIUSURA
CLAMPING HEADS



pag. 279

PINZE CON FILETTO
DRAWBACK COLLETS



pag. 280

PINZE 5C
5C COLLETS



pag. 280

CONTROPINZE
FEED FINGERS



pag. 281

PINZE PER CARICATORI CUCCHI
BAR-FEEDER COLLETS



da pag. 282

PINZE PER CARICATORI IEMCA
BAR-FEEDER COLLETS



da pag. 283

PINZE PER CARICATORI TOP AUTOMAZIONI
BAR-FEEDER COLLETS



da pag. 284

PINZE PER ALTRI CARICATORI
OTHER BAR-FEEDER COLLETS



da pag. 286

INDICE GUIDA BARRA CON METALLO DURO

INDEX OF GUIDE BUSHINGS WITH SOLID CARBIDE

REGISTRABILI TIRATE
DRAWN BACK ADJUSTABLE



pag. 287

REGISTRABILI SPINTE
PUSHED ADJUSTABLE



pag. 287

FISSE
FIXED TYPE



pag. 287

DIN 6499
ISO 15488

PINZE ER (DIN 6499 / ISO 15488)
ER COLLETS (DIN 6499 / ISO 15488)

ER - PRECISIONE STANDARD
STANDARD PRECISION TYPE

ER

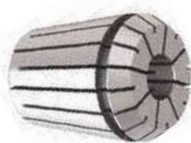

vedi pag. 11

ER HP - DI ALTA PRECISIONE
HIGH PRECISION TYPE

ER HP

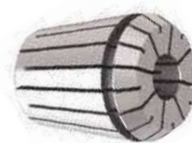

vedi pag. 16

$\leq 0,005$

JET - CON FORI DI REFRIGERAZIONE
WITH COOLANT HOLES

JET



vedi pag. 17

RF - A TENUTA STAGNA
SEALED TYPE

RF

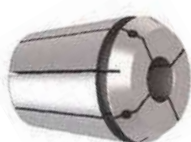

40 bar

vedi pag. 18

UP - A TENUTA STAGNA DI ULTRA PRECISIONE
ULTRA PRECISION SEALED TYPE

RF UP



40 bar

$\leq 0,005$

vedi pag. 19

SSC - A TENUTA MECCANICA PER ALTE PRESSIONI
STEEL SEALED FOR HIGH PRESSURES

SSC



130 bar

vedi pag. 20

SSC HP - A TENUTA MECCANICA DI ALTA PRECISIONE
STEEL SEALED - HIGH PRECISION TYPE

SSC HP



130 bar

$\leq 0,005$

vedi pag. 21

MF - CON QUADRO PER MASCHI
WITH SQUARE FOR TAPS

MF



vedi pag. 22

ML - A TENUTA STAGNA CON QUADRO PER MASCHI
WATERTIGHT WITH SQUARE FOR TAPS

ML

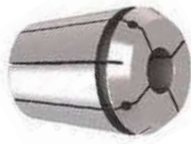

40 bar

vedi pag. 23

AM - COMPENSATE A TRAZIONE
WITH TRACTION COMPENSATION

AM



vedi pag. 24

DIN 6499
ISO 15488

GHIERE ER
ER CLAMPING NUTS

tipo MINI
MINI type



vedi pag. 27

tipo ESAGONALE
HEXAGONAL type



vedi pag. 27

tipo STANDARD
STANDARD type



vedi pag. 28

con FILETTO ESTERNO
with OUTSIDE THREAD



vedi pag. 29

con CIRCOLAZIONE di SFERE
BALL BEARING EXECUTION



vedi pag. 28

DIN 6499
ISO 15488

CHIAVI ER
ER WRENCHES

per GHIERE MINI
for MINI NUTS



vedi pag. 30

per GHIERE ESAGONALI
for HEXAGONAL NUTS



vedi pag. 30

per GHIERE STANDARD
for STANDARD NUTS



vedi pag. 30

TP-ER

TAMPONI PULITORI per SEDE PINZA ER
ER COLLET SEAT TAPER CLEANERS



SEDE ER	Art.
TP - ER 16	5375
TP - ER 20	5376
TP - ER 25	5377
TP - ER 32	5378
TP - ER 40	5379

ETS

PINZE ETS ETS COLLETS

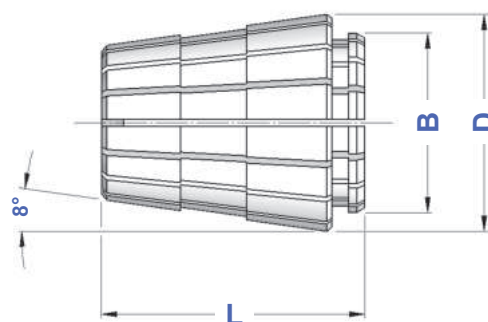
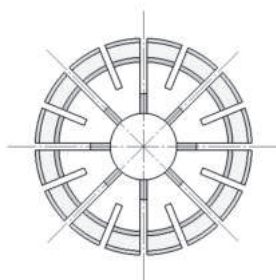

TIPO	Art.	RANGE	SERRAGGIO	STEP	D	B	L	Einheits
ETS 16	5200	1 ÷ 3 3 ÷ 10	mm 0,5 mm 1,0	0,5	17,0	13,6	24,0	4018E
ETS 20	5201	2 ÷ 3 3 ÷ 13	mm 0,5 mm 1,0	0,5	21,0	17,0	30,5	4272E
ETS 25	5202	2 ÷ 3 3 ÷ 16	mm 0,5 mm 1,0	0,5	26,0	21,0	34,0	4280E
ETS 32	5203	3 ÷ 20	mm 1,0	0,5	33,0	27,2	40,0	4534E
ETS 40	5204	3 ÷ 26	mm 1,0	0,5	41,0	32,0	46,0	4768E

Le pinze ETS sono intercambiabili con le normali pinze ER (DIN 6499 - ISO 15488) grazie alla medesima conicità posteriore di 8°.

Per poterle montare su un normale portapinza ER è necessaria la sostituzione della ghiera essendo diversa la parte anteriore.

Caratteristiche:

- elevata precisione del sistema
- ottima resa alle alte velocità

ETS collets are interchangeable with ER collets (DIN 6499 - ISO 15488) thanks to the same 8° rear taper.

To fit them in a standard ER collet chuck, a nut replacement is needed because of the difference in fore part of the collet.

Characteristics:

- system with high precision
- an excellent yield in high speed

CONTENITORE VUOTO IN PLASTICA PLASTIC EMPTY TRAY

PINZA	Art.	n° sedi
ETS 16	3674	16
ETS 20	3675	16
ETS 25	3676	20
ETS 32	3677	20
ETS 40	3678	28



CASSETTA VUOTA IN LEGNO WOODEN EMPTY BOX

PINZA	Art.	n° sedi
ETS 16	3976	12
ETS 20	3977	12
ETS 25	3978	15
ETS 32	3979	18
ETS 40	3980	24



ETS

GHIERE STANDARD PER PINZE ETS
STANDARD CLAMPING NUTS FOR ETS COLLETS



TIPO	Art.	A	B	C		
GS 16 ETS	5294	32	15,0	22 x 1,5	5200	3698
GS 20 ETS	5295	35	16,5	25 x 1,5	5201	3699
GS 25 ETS	5296	42	18,5	32 x 1,5	5202	3669
GS 32 ETS	5297	50	22,0	40 x 1,5	5203	3670
GS 40 ETS	5298	63	25,0	50 x 1,5	5204	3671

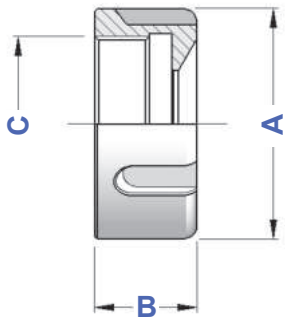

Le ghiera Standard per pinze ETS hanno il medesimo filetto delle normali ghiera ER (DIN 6499 - ISO 15488) rendendo così completamente intercambiabili i due sistemi.

Standard nuts for ETS collets have the same thread than ER Standard nuts; this makes interchangeable those two systems.

ETS

CHIAVI PER GHIERE ETS STANDARD
WRENCHES FOR STANDARD ETS NUTS

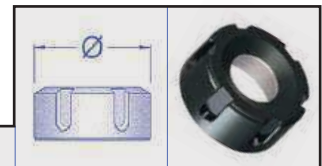

TIPO	Art.		
CH 16 ETS	3698	32	5294
CH 20 ETS	3699	35	5295
CH 25 ETS	3669	42	5296
CH 32 ETS	3670	50	5297
CH 40 ETS	3671	63	5298



TP - ETS

TAMPONI PULITORI per SEDE PINZA ETS
ETS COLLET SEAT TAPER CLEANERS



SEDE ETS	Art.	
TP - ETS 16	5375	5200
TP - ETS 20	5376	5201
TP - ETS 25	5377	5202
TP - ETS 32	5378	5203
TP - ETS 40	5379	5204



DIN 6388
ISO 10897

PINZE EOC
EOC COLLETS

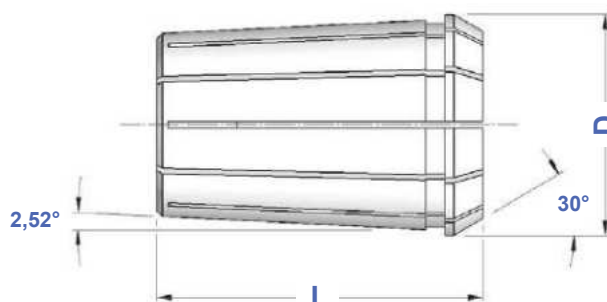

TIPO	Art.	RANGE	STEP	D	L	Einheits
EOC 6	0578	1 ÷ 6	0,5	11,50	21,0	400E
EOC 8	0624	1 ÷ 8	0,5	14,50	26,0	401E
EOC 10	0633	1 ÷ 10	0,5	17,20	30,0	404E
EOC 12	0645	1 ÷ 12	0,5	19,80	34,0	407E
EOC 16	0768	2 ÷ 16	0,5	25,50	40,0	415E
EOC 20	0783	2 ÷ 20	0,5	29,80	45,0	4541E
EOC 25	0769	2 ÷ 25	0,5	35,05	52,0	462E
EOC 32	0770	3 ÷ 32	0,5	43,70	60,0	467E
EOC 40	0802	8 ÷ 40	1,0	52,20	68,0	468E



SERIE RIDOTTA DI PINZE EOC
REDUCED SET OF EOC COLLETS

TIPO	Diametri	n° pinze
EOC 16 - Ridotta	Ø 4 - 6 - 8 - 10 - 12 - 16	6
EOC 25 - Ridotta	Ø 6 - 8 - 10 - 12 - 16 - 20 - 25	7
EOC 32 - Ridotta	Ø 6 - 8 - 10 - 12 - 16 - 20 - 25 - 32	8

IN CONFEZIONI SINGOLE
IN SINGLE PACKS



Art.

IN VALIGETTA
IN CASE



Art.

IN CONFEZIONI SINGOLE
IN SINGLE PACKS



Art.

IN VALIGETTA
IN CASE



Art.



SERIE COMPLETA DI PINZE EOC
COMPLETE SET OF EOC COLLETS

TIPO	Diametri	n° pinze
EOC 16 - Completa	da Ø 2 a Ø 16	15
EOC 25 - Completa	da Ø 2 a Ø 25	24
EOC 32 - Completa	da Ø 4 a Ø 32	29

IN CONFEZIONI SINGOLE
IN SINGLE PACKS



Art.

IN VALIGETTA
IN CASE



Art.

DIN 6388
ISO 10897

PINZE EOC A TENUTA STAGNA
WATERTIGHT EOC COLLETS

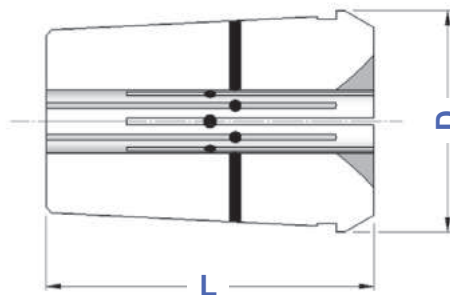

TIPO	Art.	RANGE	STEP	D	L
EOC 16 RF	0768 RF	3 ÷ 16	0,5	25,50	40
EOC 25 RF	0769 RF	3 ÷ 25	0,5	35,05	52
EOC 32 RF	0770 RF	4 ÷ 32	1,0	44,00	60



Il refrigerante viene canalizzato esclusivamente nel foro centrale grazie ad inserti in neoprene inseriti nei tagli.
Pressione di esercizio: fino a 40 Bar / 600 PSI

The coolant is channeled exclusively in the central hole thanks to neoprene insertions into the cuts
Working pressure: max 40 Bar / 600 PSI

DIN 6388
ISO 10897

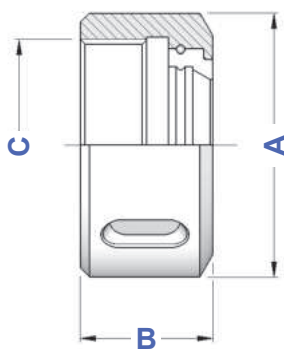
GHIERE PER PINZE EOC
CLAMPING NUTS FOR EOC COLLETS



TIPO	Art.	A	B	C		
GOC 6	8641	18	14,0	14 x 1,0	0578	2880
GOC 8	8642	26	19,0	20 x 1,5	0624	2820
GOC 10	8643	30	19,0	22 x 1,5	0633	2881
GOC 12	8644	35	20,0	27 x 1,5	0645	2882
GOC 16	4067	43	24,0	33 x 1,5	0768	2883
GOC 20	4008	50	28,0	42 x 2,0	0783	2908
GOC 25	4068	60	30,0	48 x 2,0	0769	2909
GOC 32	4069	72	33,5	60 x 2,5	0770	2910
GOC 40	8645	85	37,0	68 x 2,5	0802	2836

CHIAVI PER GHIERE GOC
WRENCHES FOR GOC NUTS



Example:
GOC 25 view



TIPO	Art.	
CH 6 GOC	2880	8641
CH 8 GOC	2820	8642
CH 10 GOC	2881	8643
CH 12 GOC	2882	8644
CH 16 GOC	2883	4067
CH 20 GOC	2908	4008
CH 25 GOC	2909	4068
CH 32 GOC	2910	4069
CH 40 GOC	2836	8645

PC

PINZE PER MANDRINI A FORTE SERRAGGIO

COLLETS FOR HIGH GRIP DEVICES

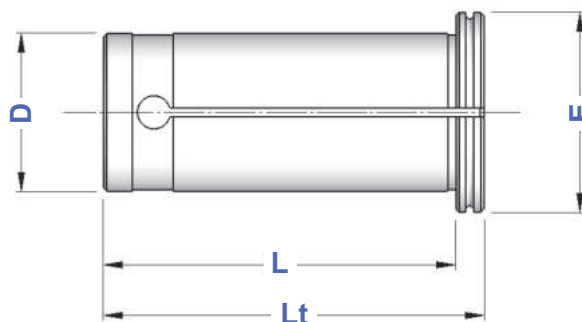

TIPO	Art.	RANGE	STEP	D	E	L	Lt
PC 12	0804	3 ÷ 8 OVERSIZE 9 ÷ 10	1,0	12	19	42,5	44,5
PC 16	0805	3 ÷ 12	1,0	16	19	46	50
PC 20	0809	3 ÷ 16 OVERSIZE 17 ÷ 18	1,0	20	25	49	52,5
PC 25	0820	3 ÷ 20 OVERSIZE 21 ÷ 22	1,0	25	31	55	60
PC 32	0810	3 ÷ 25 OVERSIZE 26 ÷ 30	1,0	32	37,5	59,5	64,5

Si raccomanda attenzione nell'utilizzo delle misure OVERSIZE perchè il diametro di presa è esasperato rispetto al diametro esterno della pinza

It is recommended to be careful when using OVERSIZE measures because the clamping diameter is exasperated compared to the external body of the collet



SERIE RIDOTTA DI PINZE PC in CONFEZIONI SINGOLE

REDUCED SET OF PC COLLETS IN SINGLE PACKS



TIPO	Diametri	n° pinze	Art.
PC 20 - Ridotta	Ø 6 - 8 - 10 - 12 - 16	5	7680
PC 25 - Ridotta	Ø 6 - 8 - 10 - 12 - 16 - 20	6	7681
PC 32 - Ridotta	Ø 6 - 8 - 10 - 12 - 16 - 20 - 25	7	7682



SERIE RIDOTTA DI PINZE PC in VALIGETTA

REDUCED SET OF PC COLLETS IN CASE



TIPO	Diametri	n° pinze	Art.
PC 20 - Ridotta	Ø 6 - 8 - 10 - 12 - 16	5	7683
PC 25 - Ridotta	Ø 6 - 8 - 10 - 12 - 16 - 20	6	7684
PC 32 - Ridotta	Ø 6 - 8 - 10 - 12 - 16 - 20 - 25	7	7685

PC - UP

PINZE PER MANDRINI A FORTE SERRAGGIO DI ULTRA PRECISIONE

ULTRA PRECISION COLLETS FOR HIGH GRIP DEVICES

**PRECISIONE
RUNOUT**

 ≤ 0,005

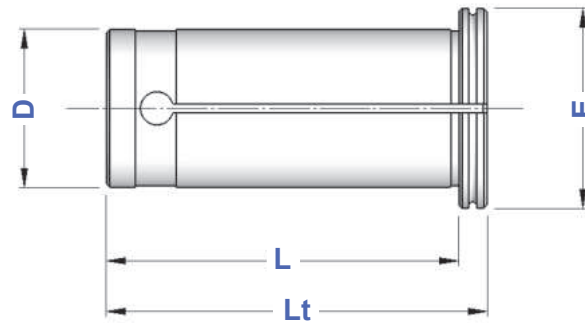

TIPO	Art.	RANGE	STEP	D	E	L	Lt
PC 20 UP	0809 UP	3 ÷ 16	1,0	20	25	49	52,5
PC 25 UP	0820 UP	3 ÷ 20	1,0	25	31	55	60
PC 32 UP	0810 UP	3 ÷ 25	1,0	32	37,5	59,5	64,5

**Pinze con le medesime caratteristiche
delle PC ma di alta precisione:
concentricità ≤ 0,005 mm.**

*Collets with the same features of PC type but with
an high precision: ≤ 0,005 runout accuracy.*



SERIE RIDOTTA DI PINZE PC-UP in CONFEZIONI SINGOLE

REDUCED SET OF PC-UP COLLETS IN SINGLE PACKS



TIPO	Diametri	n° pinze	Art.
PC 20 UP - Ridotta	Ø 6 - 8 - 10 - 12 - 16	5	7036
PC 25 UP - Ridotta	Ø 6 - 8 - 10 - 12 - 16 - 20	6	7037
PC 32 UP - Ridotta	Ø 6 - 8 - 10 - 12 - 16 - 20 - 25	7	7038



SERIE RIDOTTA DI PINZE PC-UP in VALIGETTA

REDUCED SET OF PC-UP COLLETS IN CASE



TIPO	Diametri	n° pinze	Art.
PC 20 UP - Ridotta	Ø 6 - 8 - 10 - 12 - 16	5	7039
PC 25 UP - Ridotta	Ø 6 - 8 - 10 - 12 - 16 - 20	6	7040
PC 32 UP - Ridotta	Ø 6 - 8 - 10 - 12 - 16 - 20 - 25	7	7041

PH

PINZE A TENUTA STAGNA PER MANDRINI IDRAULICI
WATERTIGHT COLLETS FOR HYDRAULIC CHUCKS

PRECISIONE
RUNOUT

 ≤ 0,005

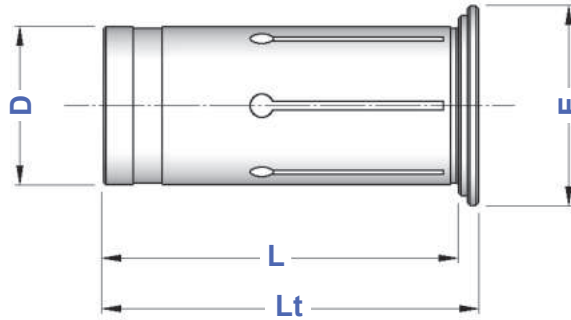

Pressione di esercizio:
fino a 70 Bar / 1020 PSI

Working pressure:
up to 70 Bar / 1020 PSI

TIPO	Art.	RANGE	STEP	D	E	L	Lt
PH 12	0520	3 ÷ 8 <i>OVERSIZE</i> 9 ÷ 10	1,0	12	16,5	45	47
PH 20	0521	3 ÷ 16 <i>OVERSIZE</i> 17 ÷ 18	1,0	20	24	50,5	52,5
PH 25	0676	6 ÷ 20 <i>OVERSIZE</i> 21 ÷ 22	1,0	25	29	54,5	56,5
PH 32	0522	6 ÷ 25 <i>OVERSIZE</i> 26 ÷ 28	1,0	32	35,5	60,5	62,5

Le misure *OVERSIZE* per le caratteristiche costruttive non consentono l'utilizzo ad elevate pressioni
OVERSIZE diameters, for the construction characteristics, do not allow the use at high pressures



SERIE RIDOTTA DI PINZE PH in CONFEZIONI SINGOLE
REDUCED SET OF PH COLLETS IN SINGLE PACKS



TIPO	Diametri	n° pinze	Art.
PH 20 - <i>Ridotta</i>	Ø 6 - 8 - 10 - 12 - 16	5	7700
PH 25 - <i>Ridotta</i>	Ø 6 - 8 - 10 - 12 - 16 - 20	6	7701
PH 32 - <i>Ridotta</i>	Ø 6 - 8 - 10 - 12 - 16 - 20 - 25	7	7702



SERIE RIDOTTA DI PINZE PH in VALIGETTA
REDUCED SET OF PH COLLETS IN CASE



TIPO	Diametri	n° pinze	Art.
PH 20 - <i>Ridotta</i>	Ø 6 - 8 - 10 - 12 - 16	5	7703
PH 25 - <i>Ridotta</i>	Ø 6 - 8 - 10 - 12 - 16 - 20	6	7705
PH 32 - <i>Ridotta</i>	Ø 6 - 8 - 10 - 12 - 16 - 20 - 25	7	7706

**DIN
6329****PINZE CONO MORSE PER PUNTE**

MT COLLETS FOR TWIST DRILLS

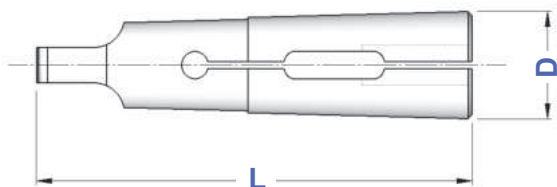

TIPO	Art.	RANGE	D	L	Einheits
CM 0 - PUNTE	5570 P	1,5 ÷ 5,5	9,2	59,5	510E
CM 1 - PUNTE	0640 P	1,5 ÷ 10,0	12,2	65,5	511E
CM 2 - PUNTE	0641 P	3,0 ÷ 15,0	18,0	80,0	514E
CM 3 - PUNTE	0642 P	8,0 ÷ 20,0	24,1	99,0	545E
CM 4 - PUNTE	0643 P	12,0 ÷ 25,0	31,6	124,0	548E
CM 5 - PUNTE	5571 P	20,0 ÷ 36,0	44,7	156,2	599E

**DIN
6328****PINZE CONO MORSE PER MASCHI**

MT COLLETS FOR MILLING CUTTERS

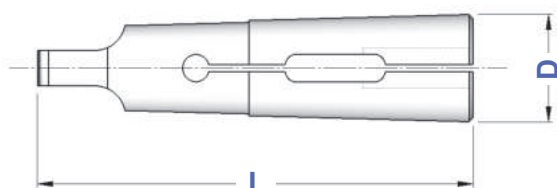

TIPO	Art.	RANGE	D	L	Einheits
CM 0 - MASCHI	5570 M	2,5 ÷ 4,5	9,2	59,5	500E
CM 1 - MASCHI	0640 M	2,5 ÷ 10,0	12,2	65,5	501E
CM 2 - MASCHI	0641 M	4,5 ÷ 14,0	18,0	80,0	504E
CM 3 - MASCHI	0642 M	8,0 ÷ 18,0	24,1	99,0	535E
CM 4 - MASCHI	0643 M	12,0 ÷ 25,0	31,6	124,0	538E
CM 5 - MASCHI	5571 M	18,0 ÷ 36,0	44,7	156,2	589E

**UNI
4702****PINZE CONO MORSE CON FILETTO**

THREADED MT COLLETS

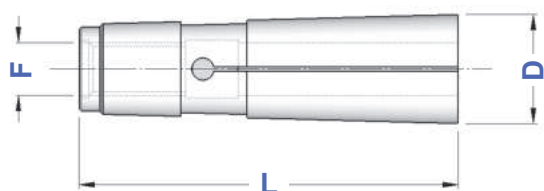

TIPO	Art.	F	RANGE	D	L	Einheits
CM 2	0752	M 10	1 ÷ 14	18,0	69,0	503E
CM 3	0712	M 12	3 ÷ 18	24,1	85,5	536E
CM 4	0865	M 16	4 ÷ 25	31,6	108,5	539E

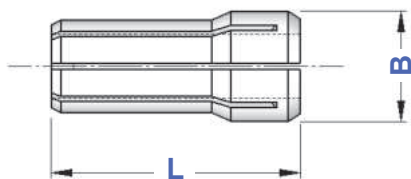
DA**PINZE DA**
DA COLLETS

DA



TIPO	Art.	B	L	RANGE	SERRAGGIO	Einheits
DA 300	5118	9,5	25,4	1 ÷ 6,5	mm 0,5	416E
DA 200	5119	13,6	30,3	1 ÷ 10,0	mm 0,5	417E
DA 100	5120	19,4	36,7	1 ÷ 15,0	mm 0,5	418E
DA 180	5121	26,2	41,6	2 ÷ 20,0	mm 0,5	419E

ESECUZIONE A TENUTA STAGNA

WATERTIGHT EXECUTION

DA RF



TIPO	Art.	B	L	RANGE	Einheits
DA 300 RF	5118 RF	9,5	25,4	3 ÷ 6,5	416E
DA 200 RF	5119 RF	13,6	30,3	3 ÷ 10,0	417E
DA 100 RF	5120 RF	19,4	36,7	3 ÷ 15,0	418E
DA 180 RF	5121 RF	26,2	41,6	3 ÷ 20,0	419E

Il refrigerante viene canalizzato esclusivamente nel foro centrale grazie ad inserti in neoprene inseriti nei tagli.
Pressione di esercizio: fino a 100 Bar / 1450 PSI

*The coolant is channeled exclusively in the central hole thanks to neoprene insertions into the cuts.
 Working pressure: up to 100 Bar / 1450 PSI*

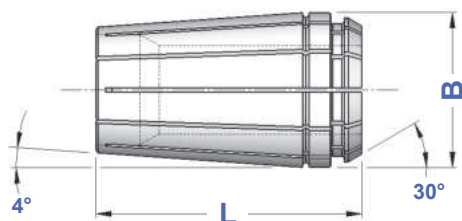
TG**PINZE TG**
TG COLLETS

TIPO	Art.	B	L	RANGE	SERRAGGIO	Einheits
TG 75	1250	27,0	46,9	2 ÷ 16	mm 0,5	420E
TG 100	1251	35,0	60,4	3 ÷ 25	mm 0,5	464E
TG 150	1252	50,8	76,2	10 ÷ 38	mm 0,5	466E

BAKUER

PINZE BAKUER

BAKUER COLLETS

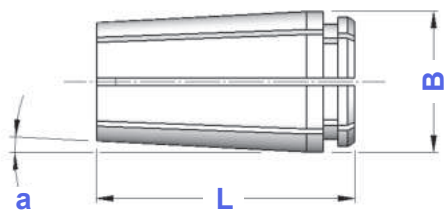

Art.	RANGE	B	L	α
0736	4,0 ÷ 16,0	25,6	48,0	3°
0737	6,0 ÷ 20,0	29,6	54,0	3°
0738	8,0 ÷ 25,0	35,7	60,0	3°

443E

PINZE 443E

443E COLLETS

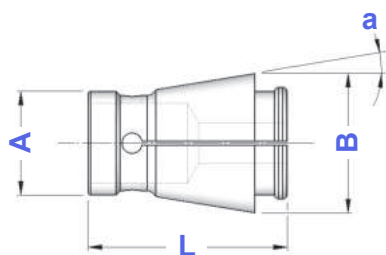

Art.	RANGE	A	B	L	α	Einheits
0772	3,0 ÷ 20	26	35	50	9° 15'	443E

BRIDGEPORT R8

PINZE BRIDGEPORT R8

BRIDGEPORT R8 COLLETS

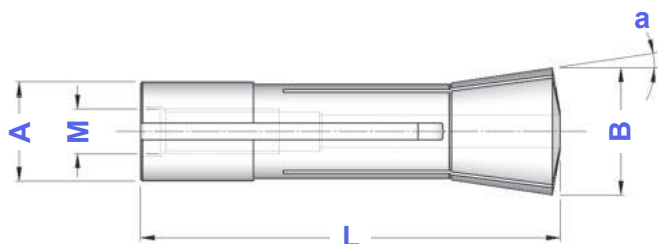

Art.	RANGE	A	B	L	α	M	Einheits
0716	2,0 ÷ 22	24,12	32	106	8° 35'	7/16 - 20"	369E

PINZE DIN 6343 - ESECUZIONI DEGLI INTERNI TONDI

DIN 6343 COLLETS - ROUND BORE EXECUTIONS

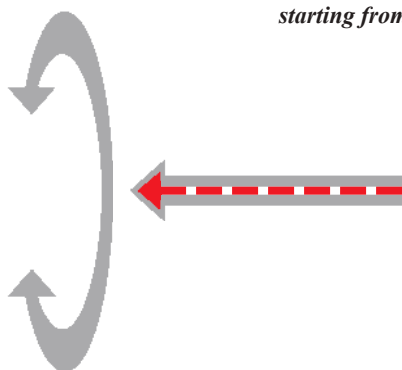
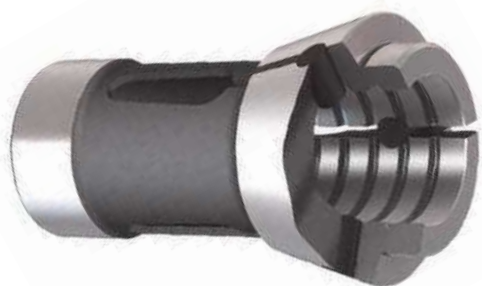
PINZA TONDA CON INTERNO RIGATO
a partire da \varnothing 8 mmGROOVED INSIDE ROUND COLLET
starting from \varnothing 8 mm

NORMALE

INTERNO
RIGATO
GROOVED**Caratteristica:** Tenuta assiale in foratura

Esempio di Ordinazione ⇨ Pinza Tonda Rigata = Art. 0709

Characteristic: Drilling Axial seal

Example for Order ⇨ 173E Grooved = Art. 0709

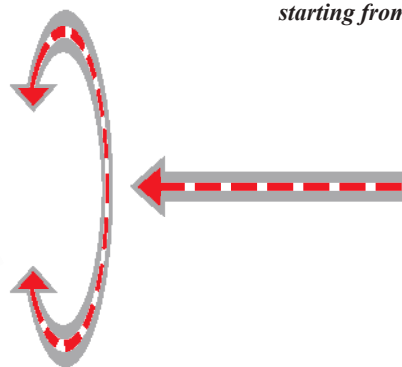
PINZA TONDA CON INTERNO QUADRETTATO
a partire da \varnothing 8 mmSERRATED INSIDE ROUND COLLET
starting from \varnothing 8 mm

TIPO S

INTERNO
QUADRETTATO
SERRATED**Caratteristica:** Tenuta assiale in foratura + tenuta in rotazione come momento torcente

Esempio di Ordinazione ⇨ Pinza Tonda Quadrettata = Art. 0709 S

Characteristic: Drilling Axial seal + rotatory seal as twisting moment

Example for Order ⇨ 173E Serrated = Art. 0709 S

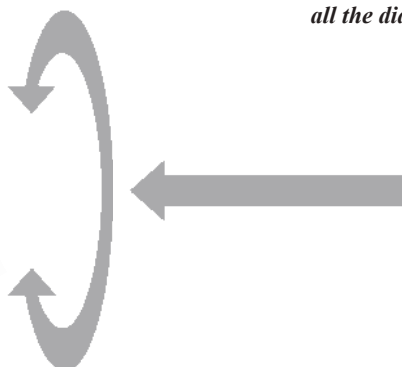
PINZA TONDA CON INTERNO LISCIO
tutti i diametriSMOOTH INSIDE ROUND COLLET
all the diameters

TIPO L

INTERNO
LISCIO
SMOOTH**Caratteristica:** Adatta per il bloccaggio di diametri finiti, non segna la superficie del materiale

Esempio di Ordinazione ⇨ Pinza Tonda Liscia = Art. 0709 L

Characteristic: Suitable to lock finished diameter, doesn't engrave material surface

Example for Order ⇨ 173E Smooth = Art. 0709 L

**DIN
6343**

PINZE DI CHIUSURA A CONO SEMPLICE
SINGLE CONE CLAMPING COLLETS

Tonda Round	Esagonale Hexagonal	Quadra Square					Ø	⬡	⬢	Einheits
Art.	Art.	Art.	A	B	L	α	max	max	max	
1072	—	—	6,0	10,0	30,0	15°	4,5	—	—	100E
5293	—	—	7,0	10,7	26,0	15°	5,0	—	—	1020E
0721	—	—	8,0	12,0	42,0	16°	6,5	—	—	101E
0725	0949	5000	10,0	15,5	47,5	20°	8,0	6,0	5,0	109E
5232	—	—	10,0	16,0	43,0	15°	7,0	—	—	110E
0749	—	—	12,0	17,0	27,0	20°	10,0	—	—	—
1132	—	—	12,0	18,0	64,0	16°	10,0	—	—	—
0940	0941	0943	13,0	19,0	64,0	16°	10,0	8,0	7,0	116E
0740	0741	0742	14,0	18,0	46,0	13°	10,0	9,0	8,0	117E
0722	0723	0724	15,0	21,0	64,0	16°	12,0	10,0	9,0	120E
5308	5309	5310	15,0	22,0	47,0	20°	11,0	9,0	8,0	121E
0913	0914	0915	16,0	22,0	55,0	15°	12,5	11,0	9,0	123E
0954	0955	0956	20,0	26,0	54,0	15°	16,0	12,0	10,0	136E
5299	5300	5301	20,0	27,5	60,0	15°	17,0	15,0	12,0	1299E
0937	0938	0939	20,0	28,0	67,0	16°	16,0	14,0	11,0	138E
0743	0744	0745	22,0	28,0	67,0	13°	16,0	14,0	12,0	139E
0705	0707	0706	22,0	30,0	55,0	15°	18,0	14,0	12,0	140E
5302	5303	5304	22,0	32,0	66,0	16°	17,0	14,0	12,0	1323E
0671	0672	0673	25,0	31,0	54,0	15°	21,0	18,0	15,0	143E
0717	0719	0718	25,0	35,0	77,0	16°	20,0	17,0	15,0	145E
0746	0747	0748	26,0	32,0	67,0	13°	20,0	18,0	15,0	146E
0901	0902	0903	27,0	38,0	72,7	15°	22,0	20,0	16,0	147E
0713	0715	0714	28,0	38,0	70,0	15°	23,0	20,0	17,0	148E
0931	0932	0933	30,0	38,0	65,0	15°	26,0	22,0	18,0	1446E
0727	0728	0729	30,0	42,0	80,0	16°	25,0	23,0	19,0	157E
0701	0703	0702	32,0	45,0	75,0	15°	26,0	24,0	20,0	161E
0615	0616	0617	35,0	43,0	70,0	15°	25,0	24,0	20,0	162E
0764	0766	0765	35,0	48,0	80,0	15°	30,0	27,0	22,0	163E
0970	0972	0973	37,0	47,0	92,0	16°	32,0	27,0	22,0	1536E
0837	0839	0838	38,0	50,3	86,0	15°	32,0	28,0	25,0	—
0919	0920	0921	38,1	49,0	107,5	15°	32,0	27,0	22,0	164E
0861	0862	0863	42,0	55,0	94,0	15°	37,0	32,0	26,0	171E
0709	0711	0710	48,0	60,0	94,0	15°	42,0	38,0	30,0	173E
0666	0667	0668	52,0	63,0	92,0	15°	46,0	38,0	32,0	—
2424	2425	2426	58,0	70,0	94,0	15°	52,0	45,0	36,0	177E
0759	0760	0761	66,0	84,0	110,0	15°	60,0	52,0	42,0	185E
0647	0648	0649	80,0	98,0	115,0	15°	70,0	60,0	50,0	—
0826	0829	0831	88,0	106,0	115,0	15°	80,0	68,0	56,0	190E
0851	0852	0853	90,0	107,0	130,0	15°	80,0	68,0	56,0	193E
0681	0683	0684	95,0	117,0	125,0	15°	80,0	68,0	56,0	—
0959	0962	0964	115,0	135,0	140,0	15°	100,0	86,0	70,0	—

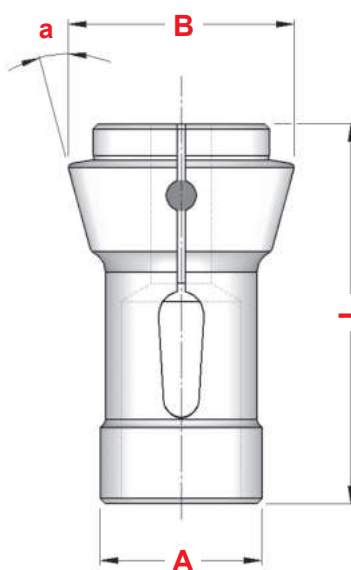

Nelle pinze tonde, l'articolo si riferisce all'esecuzione con interno rigato.
Per l'interno liscio fare seguire all'articolo la lettera **L**, per l'interno quadrettato fare seguire la lettera **S**. Vedere pagina precedente.

For round collets, the article refers to the execution with grooved inside. For the smooth inside add the letter **L**, for the serrated inside add the letter **S**. See previous page.



**DIN
6343**

PINZE DI EMERGENZA LAVORABILI
EMERGENCY COLLETS

Art.	A	B	L	α	Einheits
0717 EC	25,0	35,0	77,0	16°	145E
0701 EC	32,0	45,0	75,0	15°	161E
0970 EC	37,0	47,0	92,0	16°	1536E
0709 EC	48,0	60,0	94,0	15°	173E
2424 EC	58,0	70,0	94,0	15°	177E
0759 EC	66,0	84,0	110,0	15°	185E

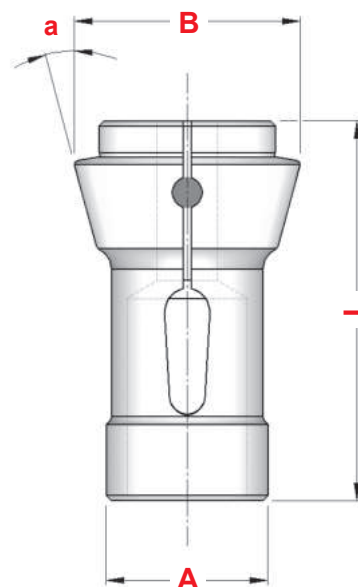

Le pinze di emergenza possono essere finite dal cliente con il diametro di presa o la sagoma desiderata grazie alla parte anteriore lavorabile. La fornitura comprende le spine di registro utili per il posizionamento nel mandrino.

Emergency collets can be finished by the customer with the diameter or the desired shape thanks to the workable front. The supply includes the register pins useful for positioning in the spindle.

Tonda Round	Esagonale Hexagonal	Quadra Square
Art.	Art.	Art.
0739	0757	0758
0756	0762	0763
0854	0855	0856
0927	0928	5053
0892	0894	0899

PINZE DI CHIUSURA A DOPPIO CONO
DOUBLE CONE CLAMPING COLLETS

B	L	E	α	\varnothing max	\varnothing max	\varnothing max
60,0	80	49,0	17°	45,0	38,0	30,0
71,6	100	60,0	17°	55,0	46,0	38,0
70,0	80	60,0	16°	52,0	45,0	35,0
91,0	100	80,0	17°	70,0	60,0	50,0
108,0	105	95,0	17°	80,0	68,0	56,0

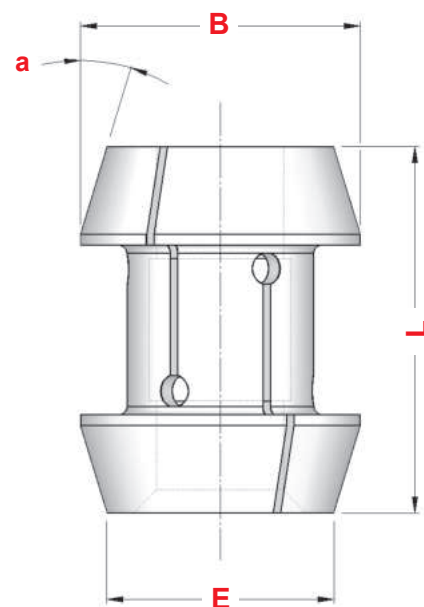

TSH

TESTE DI SERRAGGIO AD INNESTO FRONTALE FRONT LOCK CLAMPING HEADS

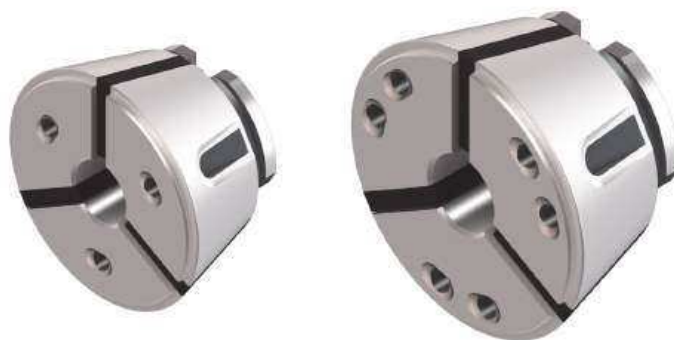
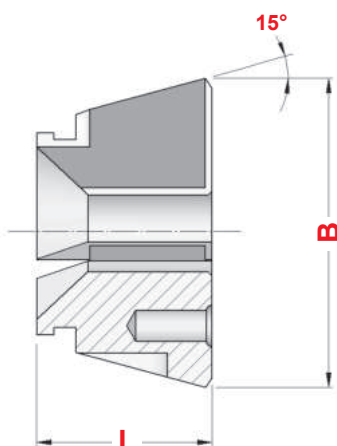

TIPO	L	B	Tonda Liscia Round Smooth		Tonda Quadrettata Round Serrated		Esagonale Hexagonal		Einheits
			Art.	Ø max	Art.	Ø max	Art.	Ø max	
TSH 42	42	79,3	9720	42,0	9721	42,0	9722	36,0	781E
	47	79,3	—	—	9723	42,0	—	—	782E
TSH 52	46	79,3	9725	52,0	9726	52,0	9727	45,0	783E
TSH 65	53	99,5	9728	65,0	9729	65,0	9730	56,0	787E
	58	99,5	—	—	9731	65,0	—	—	788E
TSH 80	53	114,5	9733	80,0	9734	80,0	9735	68,0	791E

ESTRATTORE PNEUMATICO A PEDALE PNEUMATIC CHANGING FIXTURE BY PEDAL

Art.	TIPO
8954	EPP 42
8955	EPP 52
8956	EPP 65
8957	EPP 80

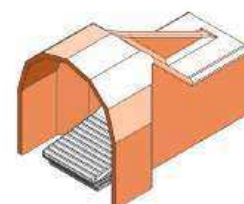
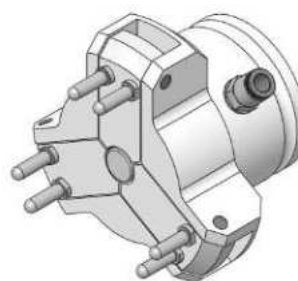

CARATTERISTICHE

- L'estratto pneumatico è fornito completo di raccordi, tubo e pedale.
- Il comando a pedale consente all'operatore di utilizzare le mani con maggiore libertà.
- Gli estrattori pneumatici EPP sono compatibili con le pinze Hainbuch®.

CHARACTERISTICS

- Pneumatic extractor is supplied complete with fittings, tube and pedal.
- The foot control allows the operator to use hands more freely.
- EPP pneumatic extractors are compatible with Hainbuch® collets

PINZE TIRATE CON FILETTO ESTERNO
DRAWN BACK COLLETS WITH EXTERNAL THREAD

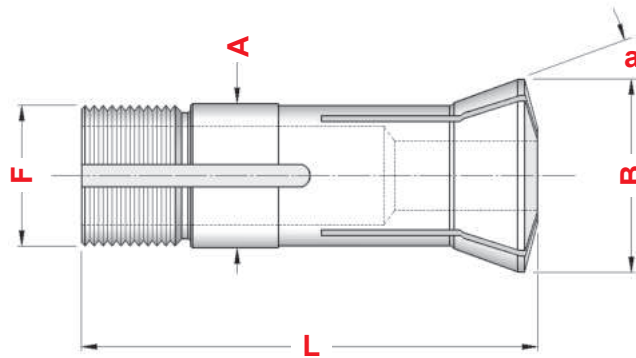

Tonda Round	Esagonale Hexagonal	Quadra Square	Art.	Art.	Art.	A	B	L	α	F	\varnothing max	W	Einheits
			Art.	Art.	Art.								
			4010	—	—	10,0	14,0	43,6	15°	9,83 x 0,83 45/5°	7,0	W10	314E
			0948	—	—	12,0	16,0	46,0	15°	11,75 x 1,25 45/5°	10,0	W12	318E
			4011	—	—	15,0	20,2	58,3	15°	14,75 x 1,25 45/5°	12,0	W15	3213E
			0750	—	—	15,0	21,5	55,0	20°	M 13 x 1,00	13,0	—	324E
			0800	—	—	20,0	26,3	73,0	15°	19,70 x 1,66 45/5°	20,0	W20	349E
			0966	—	—	20,0	28,0	122,0	17°30'	19,70 x 2,00 45/5°	20,0	—	355E
			0751	—	—	25,0	33,5	88,0	16°	M 23 x 1,00	22,0	—	363E
			0674	—	—	25,0	33,7	97,6	15°	24,70 x 15 f" 45/5°	25,0	W25	364E
			5522	5530	5580	31,75	37,3	87,0	10°03'	31,40 x 20 f" 60°	26,0	W 31,75	385E
			0597	0598	0599	35,0	44,0	103,0	20°	M 32 x 1,50	26,0	—	—

5C

PINZE TIRATE CON FILETTO ESTERNO ED INTERNO
DRAWBACK COLLETS WITH EXTERNAL AND INTERNAL THREAD

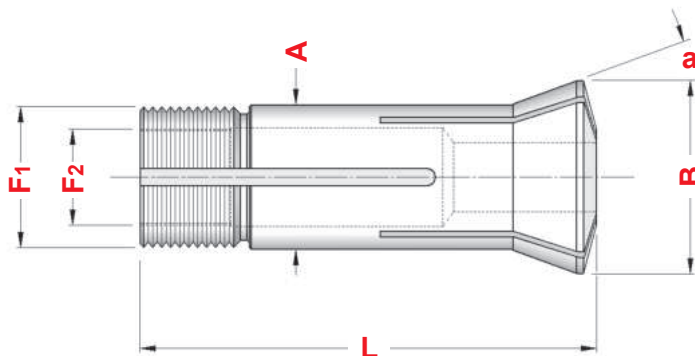

Tonda Round	Art.	A	B	L	α	F1	F2	\varnothing max	TIPO
	Art.								
	5523	31,75	37,3	87,0	10°03'	31,4 x 20 f" 60°	26,59 x 24 f"	26,0	5C

**DIN
6344**

CONTROPINZE DI AVANZAMENTO
FEED FINGERS

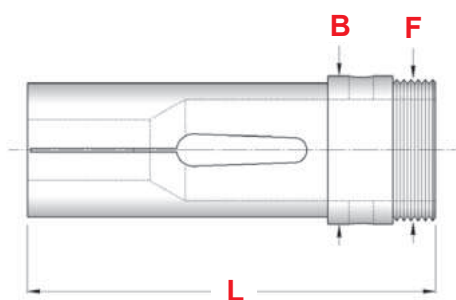

Tonda Round	Esagonale Hexagonal	Quadra Square	Art.	Art.	Art.	B	L	F	∅ max	∅ max	∅ max	Einheits
			0603	0604	0605	18	70	M 16 x 1	12,0	11,0	9,0	207E
			0874	0875	0876	24	85	M 22 x 1	19,0	17,0	12,0	220E
			0905	0906	5243	30	95	M 28 x 1	25,0	22,0	17,0	236E
			0612	0613	0614	31	90	M 29 x 1	25,0	22,0	19,0	237E
			0877	0878	0879	42	116	M 40 x 1	36,0	32,0	26,0	254E
			0880	0881	0882	60	140	M 58 x 1	52,0	45,0	36,0	273E

RIDUTTORE
REDUCTION

Art.	TIPO	F	f
2750	INDEX 36/B42 ⇔ INDEX 24/B30	M 40 x 1	M 28 x 1
2751	INDEX 36/B42 ⇔ INDEX 25	M 40 x 1	M 29 x 1
2761	INDEX 52/B60 ⇔ INDEX 36/B42	M 58 x 1	M 40 x 1

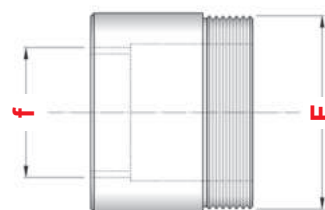

CONTROPINZE DI AVANZAMENTO PER MANDATA ESTERNA
EXTERNAL FEED FINGERS

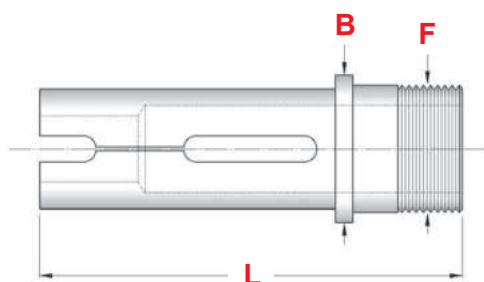

Tonda Round	Esagonale Hexagonal	Quadra Square	Art.	Art.	Art.	B	L	F	∅ max	∅ max	∅ max	Einheits
			0905L	0906L	5243L	42	120	M 36 x 1,5	30,0	26,0	21,0	242E
			0877L	0878L	0879L	56	138	M 50 x 1,5	42,0	36,0	29,0	259E
			0880L	0881L	0882L	75	138	M 68 x 1,5	60,0	52,0	42,0	278E

Tonda
Round



PINZE per CARICATORI CUCCHI
CLAMPING SLEEVES FOR CUCCHI BAR-FEEDERS

Art.	A	L	∅ min	∅ max	F destro / right
0591	20,0	59	3	18,0	M 10 x 1 DX
	22,0	59	19	20,0	
0904	40,0	70	6	37,0	M 25 x 1,5 DX
	42,0	70	38	39,0	
0935	46,0	72	37	42,0	M 25 x 1,5 DX
0945	60,0	80	30	55,0	M 25 x 1,5 DX
0708	65,0	80	55	60,0	M 25 x 1,5 DX
	69,5	80	61	65,0	
	75,0	80	66	70,0	

Art.	A	L	∅ min	∅ max	F sinistro / left
0607	19,0	60	4	16,0	M 10 x 1 SX
	20,0	60	17	18,0	
0621	23,0	60	4	20,0	M 14 x 1 SX
	25,0	60	21	23,0	
0653	37,0	70	10	34,0	M 25 x 1,5 SX
	39,0	70	35	36,0	
	41,0	70	37	39,0	
0654	47,0	70	14	43,0	M 30 x 1,5 SX
	49,0	70	44	45,0	

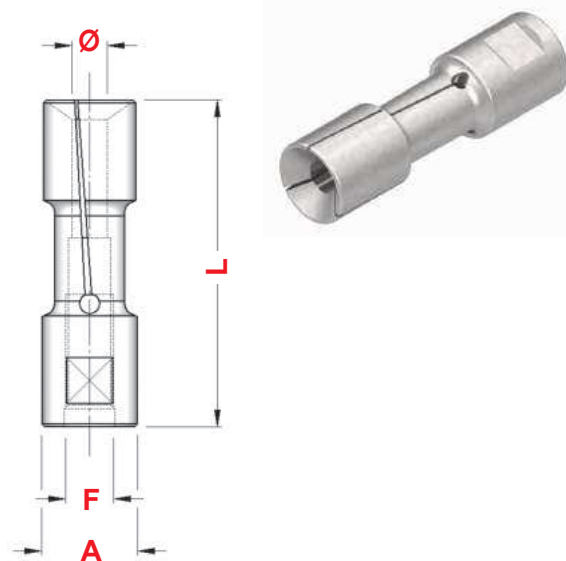

GRUPPI ROTANTI per CARICATORI CUCCHI
ROTARY DEVICES FOR CUCCHI BAR-FEEDERS

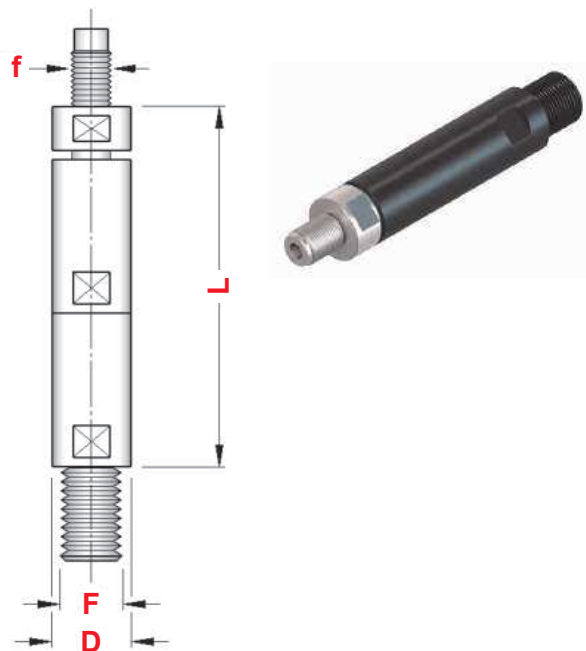

RIDUTTORI NIPLEX per CARICATORI CUCCHI
NIPLEX REDUCTIONS FOR CUCCHI BAR-FEEDERS

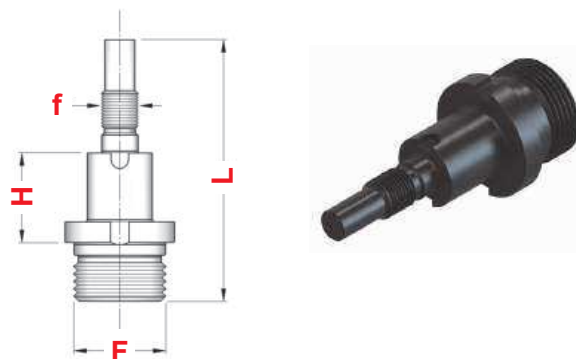

Art.	L	H	F sinistro / left	f destro / right
1781	75	26	M 25 x 1,5 SX	M 10 x 1 DX
1782	75	26	M 25 x 1,5 SX	M 14 x 1 DX
1783	75	20	M 25 x 1,5 SX	M 18 x 1,5 DX
1784	75	14	M 25 x 1,5 SX	M 25 x 1,5 DX

Art.	D	L	F destro / right	f destro / right
1539	10,0	107	M 7 x 1 DX	M 6 x 0,75 DX
1540	12,0	107	M 8 x 1,25 DX	M 7 x 0,75 DX
2199	14,0	107	M 10 x 1,5 DX	M 8 x 1 DX
2200	16,0	107	M 10 x 1,5 DX	M 8 x 1 DX
1541	19,0	118	M 12 x 1,75 DX	M 10 x 1 DX
1543	25,0	118	M 20 x 1,5 DX	M 14 x 1 DX
1544	30,0	123	M 24 x 1,5 DX	M 18 x 1,5 DX
1545	40,0	61	M 28 x 1,5 DX	M 25 x 1,5 DX

Fornibili anche nella versione con filetto sinistro
Also available left thread version

Tonda
Round



PINZE per CARICATORI IEMCA
CLAMPING SLEEVES FOR IEMCA BAR-FEEDERS

Art.	A	L	∅ min	∅ max	F destro / right
0594	7,5	40	2	6,5	M 5 x 0,5 DX
0897	10,0	40	2	8,5	M 6 x 0,75 DX
0593	12,0	42	2	10,5	M 7 x 0,75 DX
0592	15,0	42	2	13,5	M 8 x 1 DX
0591	20,0	59	3	18,0	M 10 x 1 DX
	22,0	59	19	20,0	
0891	25,0	59	4	23,0	M 10 x 1 DX
0823	30,0	65	8	28,0	M 10 x 1 DX
	32,0	65	29	30,0	
0904	40,0	70	6	37,0	M 25 x 1,5 DX
	42,0	70	38	39,0	
0935	46,0	72	37	42,0	M 25 x 1,5 DX
0945	60,0	80	30	55,0	M 25 x 1,5 DX
0708	65,0	80	55	60,0	M 25 x 1,5 DX
	69,5	80	61	65,0	
	75,0	80	66	70,0	

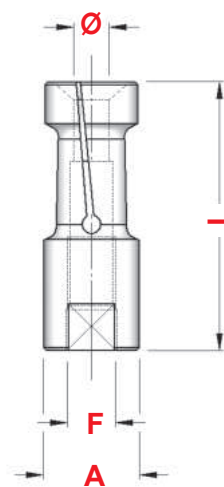

GRUPPI ROTANTI per CARICATORI IEMCA
ROTARY SETS FOR IEMCA BAR-FEEDERS

Art.	D	L	F destro / right	f destro / right
2621	7,5	126	M 6 x 0,75 DX	M 5 x 0,5 DX
2622	10,0	113	M 8 x 1 DX	M 6 x 0,75 DX
2623	12,0	116	M 10 x 1 DX	M 7 x 0,75 DX
2624	15,0	121	M 12 x 1,5 DX	M 8 x 1 DX
2625	20,0	133	M 14 x 1,5 DX	M 10 x 1 DX
2626	25,0	133	M 14 x 1,5 DX	M 10 x 1 DX
2627	30,0	135	M 14 x 1,5 DX	M 10 x 1 DX

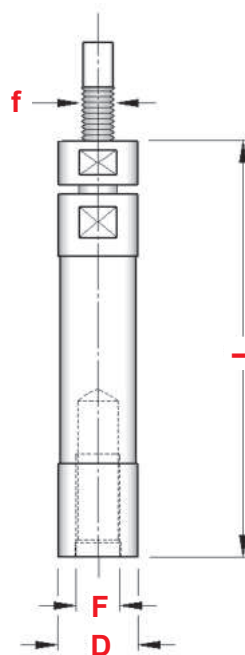

RIDUTTORI NIPLEX per CARICATORI IEMCA E CUCCHI
NIPLEX REDUCTIONS FOR IEMCA BAR-FEEDERS

Art.	L	H	F destro / right	f destro / right
1260	72	26	M 25 x 1,5 DX	M 10 x 1 DX
1373	75	26	M 25 x 1,5 DX	M 14 x 1 DX
1374	75	20	M 25 x 1,5 DX	M 18 x 1,5 DX
1375	75	14	M 25 x 1,5 DX	M 25 x 1,5 DX

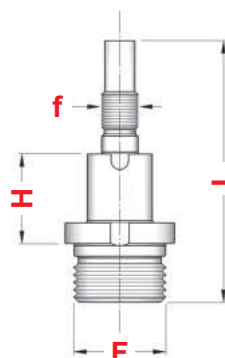

Tonda
Round



PINZE per CARICATORI TOP AUTOMAZIONI

CLAMPING SLEEVES FOR TOP AUTOMAZIONI BAR-FEEDERS

Art.	A	L	∅ min	∅ max	C	B
9700	18	80	4	13	5	14
9701	20	80	5	17	5	
9702	25	80	15	22	5	
9703	30	80	20	28	8	20
9704	35	80	26	30	8	
9705	40	80	30	35	8	
9706	45	80	36	40	8	
9707	50	80	41	45	8	
9708	55	80	46	50	8	
9709	60	80	30	55	8	
9710	65	80	55	60	8	30
9711	70	80	61	65	8	
9712	75	80	66	70	8	
9713	75	80	66	70	8	35
9714	80	80	71	75	8	
9715	85	95	76	80	8	35
9716	90	95	81	85	8	
9717	95	95	86	90	8	
9718	100	95	91	95	8	

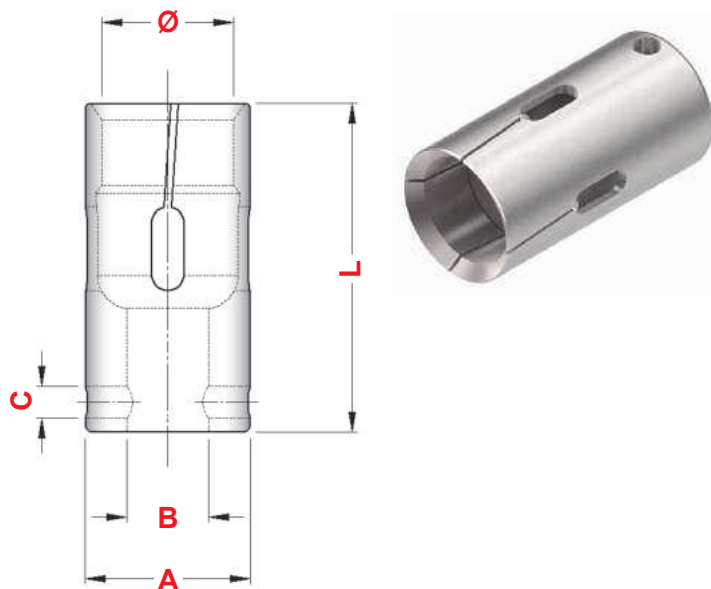

PINZE di EMERGENZA LAVORABILI IN VULKOLLAN per CARICATORI TOP AUTOMAZIONI

VULKOLLAN WORKABLE EMERGENCY CLAMPING SLEEVES FOR TOP AUTOMAZIONI BAR-FEEDERS

Art.	A	V	L	C	B
9502	14,9	12,9	80	5	10
9503	19	17	80	5	14
9504	24	22	80	5	20
	29	27	80	8	
	31	29	80	8	
	34	32	80	8	
	35	33	80	8	
	37	35	80	8	
	39	37	80	8	
	41	39	80	8	
	44	42	80	8	
	49	47	80	8	
	51	49	80	8	
	54	52	80	8	
	59	57	80	8	
61	59	80	8		
64	62	80	8		
69	67	80	8		
9505	71	69	80	8	30
	74	72	80	8	
	79	77	80	8	
	81	79	80	8	
	84	82	80	8	
	89	87	80	8	
	94	92	80	8	
	99	97	80	8	
	109	107	80	8	

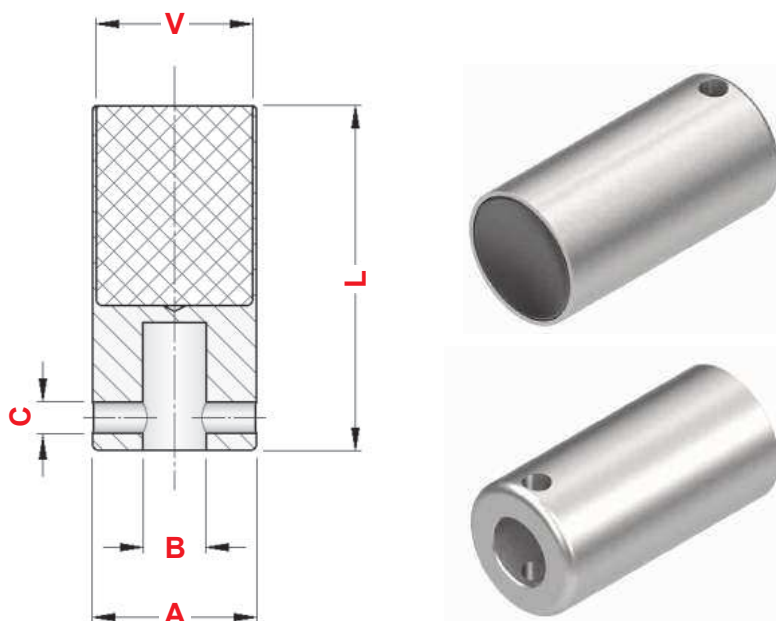

Le pinze di emergenza lavorabili possono essere finite dal cliente con il diametro desiderato grazie alla parte interna in Vulkollan.

Workable emergency collets can be finished by the customer with the desired diameter thanks to the Vulkollan inner part.

Tonda
Round



PINZE CARICATORI TOP AUTOMAZIONI per TORNI a FANTINA
CLAMPING SLEEVES TOP AUTOMAZIONI BAR-FEEDERS FOR SLIDING HEADSTOCK LATHES

Art.	A	L	∅	C	B
9522	15	52	3 ÷ 13	5	10
	18	52	14 ÷ 16		
9523	20	52	17 ÷ 18	5	14
	22	52	19		
	23	52	20		
	25	52	21 ÷ 22		
	27	52	23		
	28	52	24		
	29	52	25		
	30	52	26		

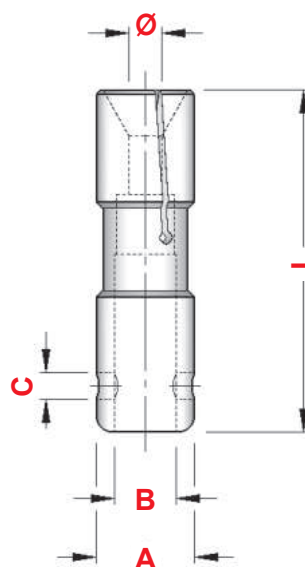

RACCORDI NIPLEX per CARICATORI TOP AUTOMAZIONI
NIPLEX FOR TOP AUTOMAZIONI BAR-FEEDERS

Art.	B	E	A	C	C1	L
9506	10	14	18	5	5	79
9507	14	14	19	5	5	79
9508	14	20	30	5	8	91
9509	14	25	35	5	8	91
9510	14	30	50	5	8	91
9511	20	20	30	8	8	91
9512	20	25	35	8	8	91
9513	20	30	50	8	8	91
9514	30	30	50	8	8	91
9524	35	30	70	8	8	81

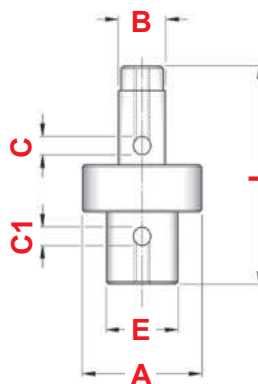

SPINE di BLOCCAGGIO PINZA
COLLET LOCKING PINS

Art.	D	L
9515	5	15
9516	5	19
9517	5	24
9525	5	27
9526	5	35
9518	8	30
9519	8	40
9520	8	45
9521	8	60

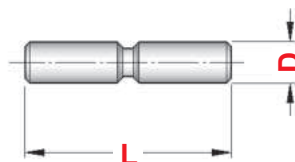

PINZE per ALTRI CARICATORI
CLAMPING SLEEVES FOR OTHER BAR-FEEDERS



Tonda
Round

Art.	D	L	f	∅ min	∅ max	Einheits
1308	5,0	37	M 4	1,5	4,0	200E
1309	6,0	30	M 4	1,5	4,5	—
1386	7,0	30	M 4	2,0	5,0	—
1387	7,0	37	M 5	2,0	5,5	208E
1388	10,0	30	M 5	2,0	8,0	—
1415	12,0	30	M 6	3,0	9,5	—
1446	12,5	30	M 6	9,5	10,5	—
1470	16,5	35	M 8	4,0	14,5	—
1477	20,0	35	M10	4,0	18,0	—

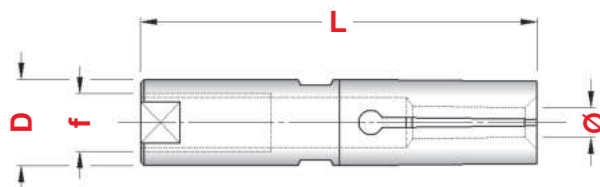

Tonda
Round

Art.	D	L	d	B	I	∅ min	∅ max	Einheits
1647	10	40	7 - H7	4	6	3,0	8,0	210E
1663	12	40	8 - H7	4	6	3,0	10,0	212E
1676	15	40	11 - H7	6	6	3,0	13,0	203E
1704	16	40	11 - H7	6	6	3,0	14,0	—
1744	18	40	11 - H7	6	6	3,0	16,0	203E-18
1861	20	65	14 - H7	8	7	4,0	18,0	225E
1863	25	65	20 - H7	8	7	4,0	22,0	222E
1869	32	65	20 - H7	8	7	10,0	30,0	—
1932	36	65	20 - H7	8	7	10,0	35,0	—

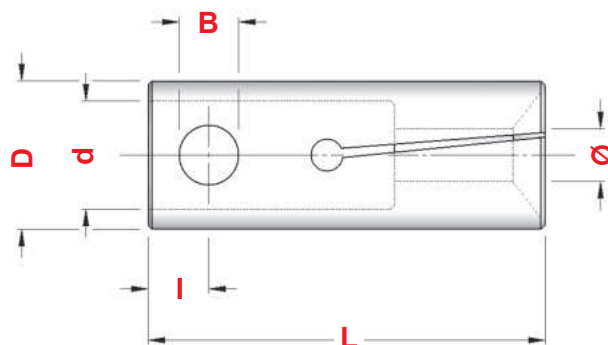

Tonda
Round

Art.	D	L	d	∅ min	∅ max	F	Einheits
1512	25	90	20 - H7	3,0	20,0	M 5	2292E
1549	32	90	20 - H7	5,0	29,5	M 6	2422E
1566	36	90	20 - H7	5,0	33,0	M 8	2490E
1644	42	90	20 - H7	6,0	39,0	M 8	—
1645	45	90	20 - H7	6,0	42,0	M 8	—

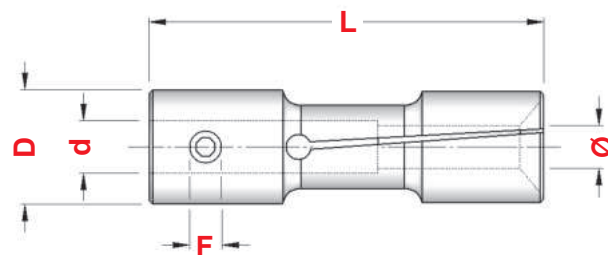

Tonda
Round

GUIDA BARRA REGISTRABILI CON METALLO DURO - TIPO TIRATO
DRAWN BACK ADJUSTABLE GUIDE BUSHINGS WITH SOLID CARBIDE

Art.	A	L	B	α	F
0698	9	44,0	12,5	16°	M 8 x 0,75
0655	12	50,0	16,0	16°	M 10 x 0,75
0686	12	50,0	15,0	30°	M 12 x 1,00
0909	16	59,0	20,5	16°	M 14 x 1,00
0687	18	60,0	21,8	30°	M 16 x 1,00
0688	20	55,0	25,0	30°	M 20 x 1,00
0799	22	68,0	29,0	16°	M 19 x 1,00
0926	22	68,0	29,0	16°	M 22 x 1,00
4040	24	61,0	30,0	30°	M 24 x 1,00
0602	28	81,0	38,0	30°	M 25 x 1,00
0699	28	82,0	34,0	16°	M 25 x 1,00
0803	32	71,0	40,0	30°	M 32 x 1,00
0812	34	87,5	41,0	10°	M 34 x 1,00
0689	40	71,0	48,0	30°	M 40 x 1,00
0930	42	82,0	49,0	16°	M 40 x 1,00

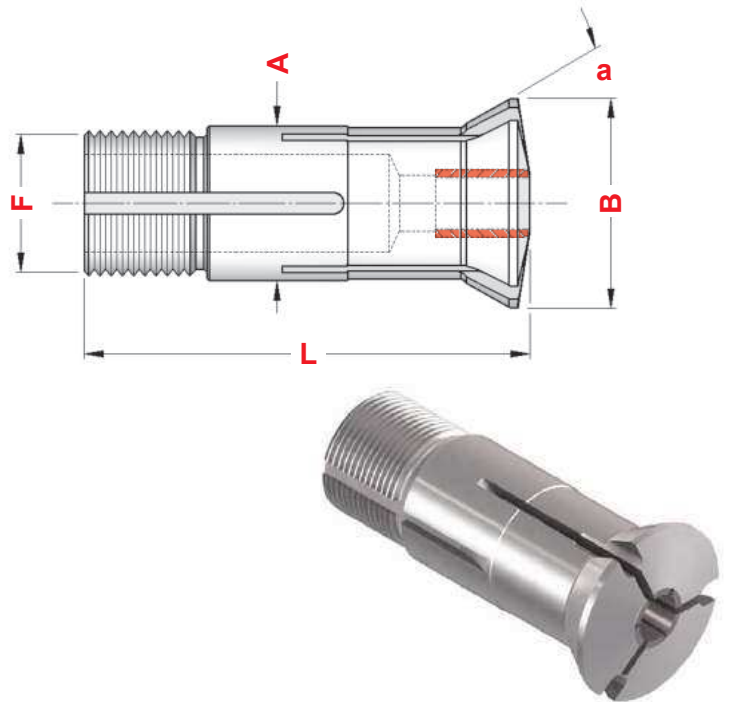

Tonda
Round

GUIDA BARRA REGISTRABILI CON METALLO DURO - TIPO SPINTO
PUSHED ADJUSTABLE GUIDE BUSHINGS WITH SOLID CARBIDE

Art.	A	L	α	b
0691	16	40	30°	30°
0692	20	40	30°	30°
0887	30	60	29°	29°
0888	34	60	29°	29°

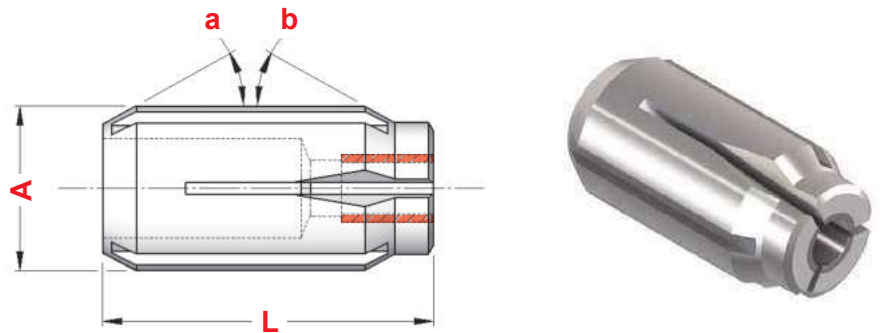

Tonda
Round

GUIDA BARRA CON METALLO DURO - TIPO FISSO
FIXED GUIDE BUSHINGS WITH SOLID CARBIDE

Art.	A	L
4028	13	30
0677	15	30
0678	16	30
0679	20	30
0680	25	35
0682	32	45

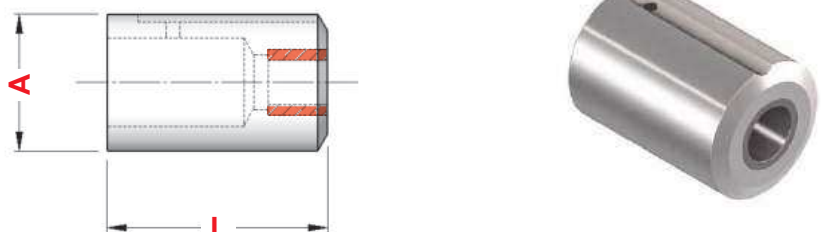

INDICE DELLE BUSSOLE DI RIDUZIONE

INDEX OF REDUCTION SLEEVES

**BUSSOLE UNIVERSALI
SENZA BATTUTA**
UNIVERSAL WITHOUT STOP



pag. 289

**BUSSOLE UNIVERSALI
CON BATTUTA**
UNIVERSAL WITH STOP



pag. 290 - 291

**BUSSOLE CON
ASOLA E BATTUTA**
SLOTTED WITH STOP



pag. 292

**BUSSOLE CON ASOLA
E GRANO SULLA BATTUTA**
WITH SLOT AND GRAIN ON STOP



pag. 293

**BUSSOLE
CON PROLUNGA**
WITH EXTENSION



pag. 294

**BUSSOLE RZ
TAGLIATE CON BATTUTA**
SPLITTED WITH STOP



pag. 295

**BUSSOLE DI RIDUZIONE
PER PORTABARENI**
FOR BORING BAR HOLDERS



pag. 297

**BUSSOLE SENZA BATTUTA
CONO MORSE**
MORSE TAPER WITHOUT STOP



pag. 298

**BUSSOLE CON BATTUTA
CONO MORSE**
MORSE TAPER WITH STOP



pag. 299

BUSSOLE BIGLIA
BIGLIA REDUCTION SLEEVES



pag. 300 - 301

BUSSOLE DOOSAN
DOOSAN REDUCTION SLEEVES



pag. 302 - 303

BUSSOLE MAZAK
MAZAK REDUCTION SLEEVES



pag. 304 - 305

BUSSOLE DMG MORI SEIKI
DMG MORI SEIKI REDUCTION SLEEVES



pag. 306 - 309

BUSSOLE NAKAMURA TOME
NAKAMURA TOME REDUCTION SLEEVES



pag. 309

BUSSOLE OKUMA
OKUMA REDUCTION SLEEVES



pag. 310 - 311

E 2.1
E 2.2

BUSSOLE DI RIDUZIONE UNIVERSALI SENZA BATTUTA
UNIVERSAL REDUCTION SLEEVES WITHOUT STOP

Figura 1	HRC 55-58
Figura 2	HRC 32-34



Figura 1



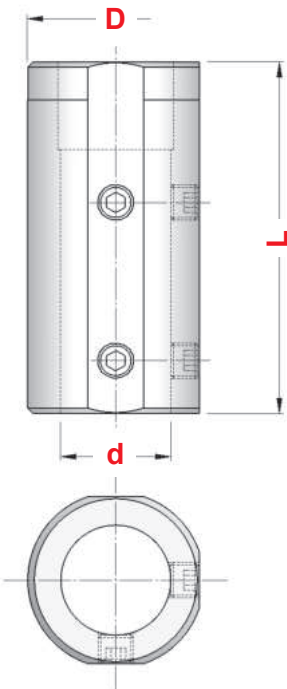

Figura 2

TIPO	Art.	D	d	L	A	Fig.	
E 2.1 - 20 x 6	2770	20	6	60	-	1	0365
E 2.1 - 20 x 8	2778	20	8	60	-	1	0368
E 2.1 - 20 x 10	2779	20	10	60	-	1	0367
E 2.1 - 20 x 12	2780	20	12	60	-	1	0367
E 2.1 - 25 x 6	2837	25	6	60	-	1	0365
E 2.1 - 25 x 8	4300	25	8	60	-	1	0020
E 2.1 - 25 x 10	4301	25	10	60	-	1	0020
E 2.1 - 25 x 12	4302	25	12	60	-	1	0368
E 2.1 - 25 x 14	2771	25	14	60	-	1	0367
E 2.2 - 25 x 16	4318	25	16	60	9	2	-
E 2.1 - 32 x 6	2838	32	6	70	-	1	0366
E 2.1 - 32 x 8	4303	32	8	70	-	1	4970
E 2.1 - 32 x 10	4304	32	10	70	-	1	4970
E 2.1 - 32 x 12	4305	32	12	70	-	1	0370
E 2.1 - 32 x 14	2839	32	14	70	-	1	0020
E 2.1 - 32 x 16	4306	32	16	70	-	1	0020
E 2.1 - 32 x 18	2841	32	18	70	-	1	0020
E 2.1 - 32 x 20	4307	32	20	70	-	1	0372
E 2.2 - 32 x 25	4319	32	25	70	14	2	-
E 2.1 - 40 x 6	7059	40	6	80	-	1	0366
E 2.1 - 40 x 8	4308	40	8	80	-	1	0181
E 2.1 - 40 x 10	4309	40	10	80	-	1	0371
E 2.1 - 40 x 12	4310	40	12	80	-	1	0371
E 2.1 - 40 x 14	2845	40	14	80	-	1	0371
E 2.1 - 40 x 16	4311	40	16	80	-	1	4970
E 2.1 - 40 x 18	2847	40	18	80	-	1	4970
E 2.1 - 40 x 20	4312	40	20	80	-	1	0021
E 2.1 - 40 x 25	4313	40	25	80	-	1	0372
E 2.2 - 40 x 32	4320	40	32	80	14	2	-
E 2.1 - 50 x 12	7061	50	12	90	-	1	0181
E 2.1 - 50 x 14	7062	50	14	90	-	1	0181
E 2.1 - 50 x 16	4314	50	16	90	-	1	0375
E 2.1 - 50 x 18	2792	50	18	90	-	1	0375
E 2.1 - 50 x 20	4315	50	20	90	-	1	0375
E 2.1 - 50 x 25	4316	50	25	90	-	1	4971
E 2.1 - 50 x 32	4317	50	32	90	-	1	0021
E 2.2 - 50 x 40	4321	50	40	90	14	2	-
E 2.1 - 60 x 16	8886	60	16	160	-	1	0183
E 2.1 - 60 x 20	8887	60	20	160	-	1	0183
E 2.1 - 60 x 25	8888	60	25	160	-	1	0377
E 2.1 - 60 x 32	8889	60	32	160	-	1	4972
E 2.1 - 60 x 40	8890	60	40	160	-	1	0385

EG.1
EG.2

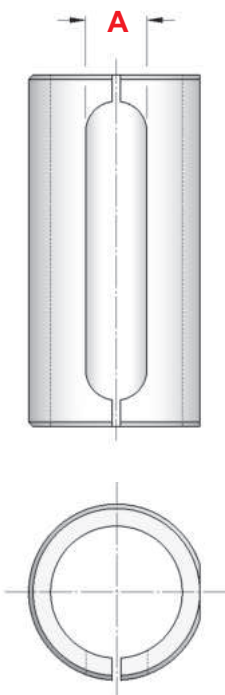
BUSSOLE DI RIDUZIONE UNIVERSALI CON BATTUTA
UNIVERSAL REDUCTION SLEEVES WITH STOP

Figura 1	HRC 55-58
Figura 2	HRC 32-34



Figura 1





Figura 2

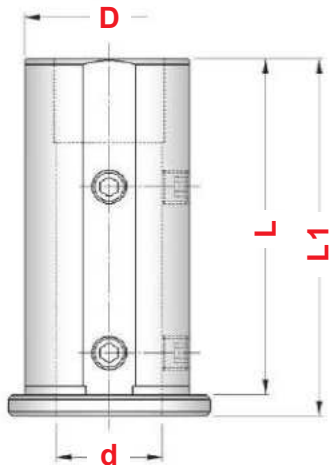

TIPO	Art.	D	d	L	L1	D1	A	Fig.	
EG.1 - 20 x 6	5964	20	6	50	55	28	—	1	0365
EG.1 - 20 x 8	5965	20	8	50	55	28	—	1	0368
EG.1 - 20 x 10	5966	20	10	50	55	28	—	1	0367
EG.1 - 20 x 12	5967	20	12	50	55	28	—	1	0367
EG.2 - 20 x 14	5994	20	14	50	55	28	9	2	—
EG.1 - 25 x 6	5968	25	6	60	65	33	—	1	0365
EG.1 - 25 x 8	5969	25	8	60	65	33	—	1	0020
EG.1 - 25 x 10	5970	25	10	60	65	33	—	1	0020
EG.1 - 25 x 12	5971	25	12	60	65	33	—	1	0368
EG.1 - 25 x 14	5972	25	14	60	65	33	—	1	0367
EG.2 - 25 x 16	5995	25	16	60	65	33	9	2	—
EG.2 - 25 x 18	5996	25	18	60	65	33	9	2	—
EG.1 - 32 x 6	5973	32	6	70	75	40	—	1	0366
EG.1 - 32 x 8	5974	32	8	70	75	40	—	1	4970
EG.1 - 32 x 10	5975	32	10	70	75	40	—	1	4970
EG.1 - 32 x 12	5976	32	12	70	75	40	—	1	0370
EG.1 - 32 x 14	5977	32	14	70	75	40	—	1	0020
EG.1 - 32 x 16	5978	32	16	70	75	40	—	1	0020
EG.1 - 32 x 18	5979	32	18	70	75	40	—	1	0020
EG.1 - 32 x 20	5980	32	20	70	75	40	—	1	0372
EG.2 - 32 x 25	5997	32	25	70	75	40	14	2	—
EG.1 - 40 x 6	5960	40	6	80	85	48	—	1	0366
EG.1 - 40 x 8	5981	40	8	80	85	48	—	1	0181
EG.1 - 40 x 10	5982	40	10	80	85	48	—	1	0371
EG.1 - 40 x 12	5983	40	12	80	85	48	—	1	0371
EG.1 - 40 x 14	5984	40	14	80	85	48	—	1	0371
EG.1 - 40 x 16	5985	40	16	80	85	48	—	1	4970
EG.1 - 40 x 18	5986	40	18	80	85	48	—	1	4970
EG.1 - 40 x 20	5987	40	20	80	85	48	—	1	0021
EG.1 - 40 x 25	5988	40	25	80	85	48	—	1	0372
EG.2 - 40 x 32	5998	40	32	80	85	48	14	2	—
EG.1 - 50 x 8	7063	50	8	90	95	58	—	1	0181
EG.1 - 50 x 10	7064	50	10	90	95	58	—	1	0371
EG.1 - 50 x 12	7065	50	12	90	95	58	—	1	0371
EG.1 - 50 x 14	7066	50	14	90	95	58	—	1	0371
EG.1 - 50 x 16	5989	50	16	90	95	58	—	1	0375
EG.1 - 50 x 18	5990	50	18	90	95	58	—	1	0375
EG.1 - 50 x 20	5991	50	20	90	95	58	—	1	0375
EG.1 - 50 x 25	5992	50	25	90	95	58	—	1	4971
EG.1 - 50 x 32	5993	50	32	90	95	58	—	1	0021
EG.2 - 50 x 40	5999	50	40	90	95	58	14	2	—

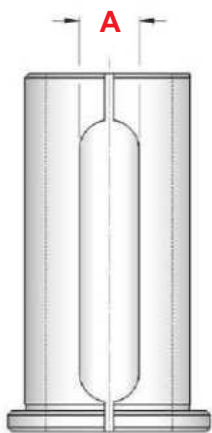
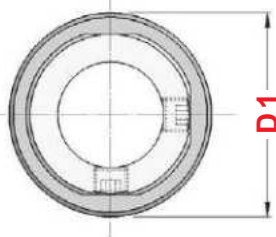
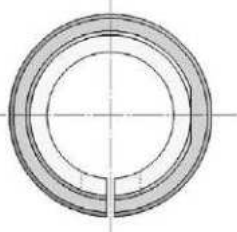
**EG.3
EG.4**

BUSSOLE DI RIDUZIONE UNIVERSALI LUNGHE CON BATTUTA
EXTENDED UNIVERSAL REDUCTION SLEEVES WITH STOP

Figura 1	HRC 55-58
Figura 2	HRC 32-34



Figura 1





Figura 2

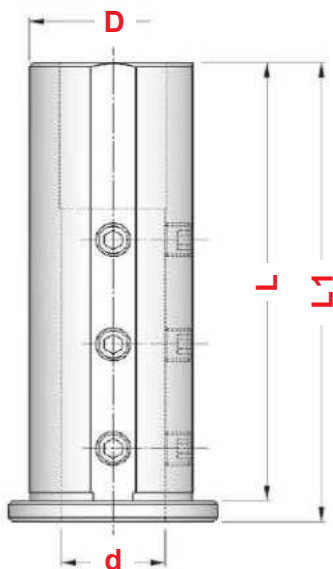

TIPO	Art.	D	d	L	L1	D1	A	Fig.	
EG.3 - 32 x 6	5315	32	6	85	90	40	-	1	0366
EG.3 - 32 x 8	5316	32	8	85	90	40	-	1	4970
EG.3 - 32 x 10	5317	32	10	85	90	40	-	1	0370
EG.3 - 32 x 12	5318	32	12	85	90	40	-	1	0370
EG.3 - 32 x 14	7042	32	14	85	90	40	-	1	0370
EG.3 - 32 x 16	5319	32	16	85	90	40	-	1	0020
EG.3 - 32 x 18	7043	32	18	85	90	40	-	1	0020
EG.3 - 32 x 20	5320	32	20	85	90	40	-	1	0367
EG.4 - 32 x 25	5333	32	25	85	90	40	11	2	-
EG.3 - 40 x 6	5321	40	6	105	110	50	-	1	0366
EG.3 - 40 x 8	5322	40	8	105	110	50	-	1	0181
EG.3 - 40 x 10	5323	40	10	105	110	50	-	1	0371
EG.3 - 40 x 12	5324	40	12	105	110	50	-	1	0371
EG.3 - 40 x 14	5918	40	14	105	110	50	-	1	0371
EG.3 - 40 x 16	5325	40	16	105	110	50	-	1	4971
EG.3 - 40 x 18	5919	40	18	105	110	50	-	1	4971
EG.3 - 40 x 20	5326	40	20	105	110	50	-	1	0021
EG.3 - 40 x 25	5327	40	25	105	110	50	-	1	0372
EG.4 - 40 x 32	5334	40	32	105	110	50	13	2	-
EG.3 - 50 x 12	5328	50	12	125	130	60	-	1	0382
EG.3 - 50 x 14	7044	50	14	125	130	60	-	1	0382
EG.3 - 50 x 16	5329	50	16	125	130	60	-	1	0375
EG.3 - 50 x 18	7045	50	18	125	130	60	-	1	0375
EG.3 - 50 x 20	5330	50	20	125	130	60	-	1	0375
EG.3 - 50 x 25	5331	50	25	125	130	60	-	1	4971
EG.3 - 50 x 32	5332	50	32	125	130	60	-	1	0021
EG.4 - 50 x 40	5335	50	40	125	130	60	13	2	-
EG.3 - 60 x 20	8840	60	20	135	140	70	-	1	0186
EG.3 - 60 x 25	8841	60	25	135	140	70	-	1	0377
EG.3 - 60 x 32	8842	60	32	135	140	70	-	1	4972
EG.3 - 60 x 40	8843	60	40	135	140	70	-	1	0385
EG.4 - 60 x 50	8844	60	50	135	140	70	13	2	-
EG.3 - 80 x 25	8845	80	25	145	150	90	-	1	4973
EG.3 - 80 x 32	8846	80	32	145	150	90	-	1	4973
EG.3 - 80 x 40	8847	80	40	145	150	90	-	1	4973
EG.3 - 80 x 50	8848	80	50	145	150	90	-	1	4973
EG.4 - 80 x 60	8849	80	60	145	150	90	14	2	-

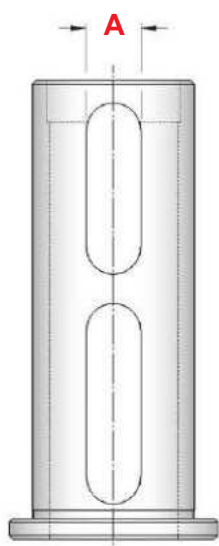
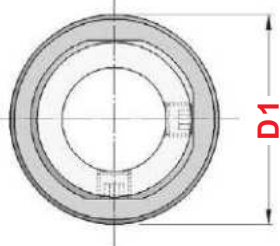
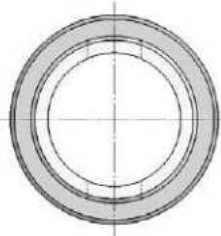
EG.5

BUSSOLE DI RIDUZIONE CON ASOLA E BATTUTA
SLOTTED REDUCTION SLEEVES WITH STOP

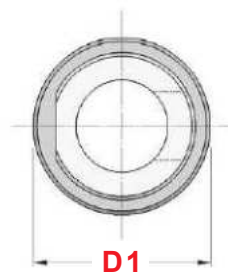
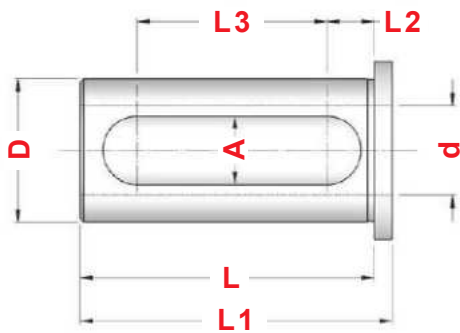

TIPO	Art.	D	d	L	L1	L2	L3	A	D1
EG.5 - 20 x 8	8796	20	8	44	47	9,5	25	11	25
EG.5 - 20 x 10	8797	20	10	44	47	9,5	25	11	25
EG.5 - 20 x 12	8798	20	12	44	47	9,5	25	11	25
EG.5 - 20 x 14	8880	20	14	44	47	9,5	25	11	25
EG.5 - 20 x 16	8799	20	16	44	47	9,5	25	11	25
EG.5 - 25 x 8	8557	25	8	54	57	8,5	33	13	30
EG.5 - 25 x 10	8558	25	10	54	57	8,5	33	13	30
EG.5 - 25 x 12	8559	25	12	54	57	8,5	33	13	30
EG.5 - 25 x 14	8560	25	14	54	57	8,5	33	13	30
EG.5 - 25 x 16	8561	25	16	54	57	8,5	33	13	30
EG.5 - 25 x 18	8562	25	18	54	57	8,5	33	13	30
EG.5 - 25 x 20	8563	25	20	54	57	8,5	33	13	30
EG.5 - 32 x 8	8564	32	8	64	68	8,5	42	13	37
EG.5 - 32 x 10	8565	32	10	64	68	8,5	42	13	37
EG.5 - 32 x 12	8566	32	12	64	68	8,5	42	13	37
EG.5 - 32 x 14	8567	32	14	64	68	8,5	42	13	37
EG.5 - 32 x 16	8568	32	16	64	68	8,5	42	13	37
EG.5 - 32 x 18	8569	32	18	64	68	8,5	42	13	37
EG.5 - 32 x 20	8570	32	20	64	68	8,5	42	13	37
EG.5 - 32 x 25	8571	32	25	64	68	8,5	42	13	37
EG.5 - 40 x 12	8835	40	12	74	79	9	51	14	45
EG.5 - 40 x 14	8836	40	14	74	79	9	51	14	45
EG.5 - 40 x 16	8837	40	16	74	79	9	51	14	45
EG.5 - 40 x 18	8838	40	18	74	79	9	51	14	45
EG.5 - 40 x 20	8897	40	20	74	79	9	51	14	45
EG.5 - 40 x 25	8898	40	25	74	79	9	51	14	45
EG.5 - 40 x 32	8899	40	32	74	79	9	51	14	45

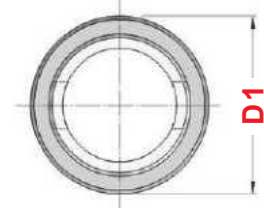
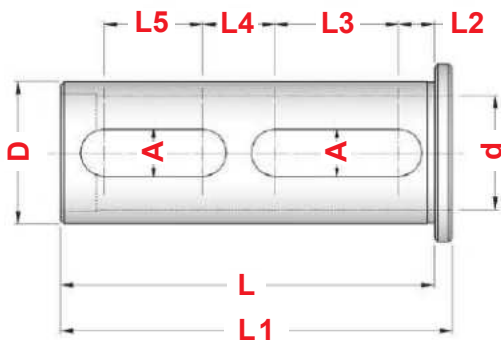



**VERSIONE LUNGA
CON DOPPIA ASOLA**
LONG TYPE WITH DOUBLE SLOT

TIPO	Art.	D	d	L	L1	L2	L3	L4	L5	A	D1
EG.4 - 25 x 16	8839	25	16	60	65	9	13	15	12	11	33
EG.4 - 32 x 25	5333	32	25	85	90	9	25	18	22	11	40
EG.4 - 40 x 32	5334	40	32	105	110	10	35	20	28	13	50
EG.4 - 50 x 40	5335	50	40	125	130	10	45	20	37	13	60
EG.4 - 60 x 50	8844	60	50	135	140	15	40	28	28	13	70
EG.4 - 80 x 60	8849	80	60	145	150	25	30	25	15	14	90

EG.6

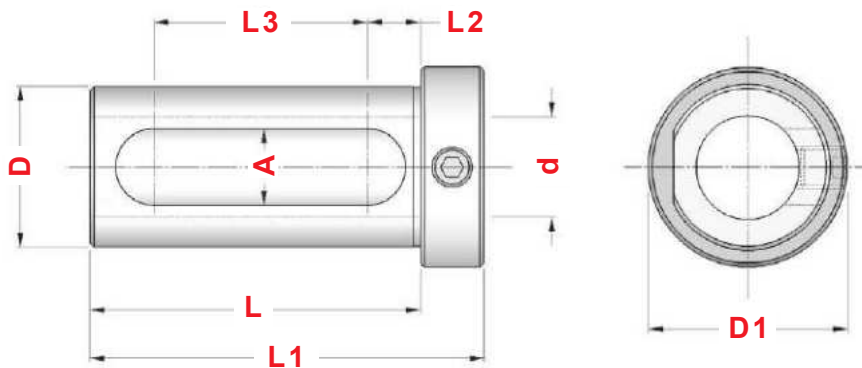
BUSSOLE DI RIDUZIONE CON ASOLA E GRANO SULLA BATTUTA
SLOTTED REDUCTION SLEEVES WITH GRAIN ON THE STOP



TIPO	Art.	D	d	L	L1	L2	L3	A	D1	
EG. 6 - 20 x 8	8754	20	8	49	59	7,5	29	11	27	0370
EG. 6 - 20 x 10	8755	20	10	49	59	7,5	29	11	27	0370
EG. 6 - 20 x 12	8756	20	12	49	59	7,5	29	11	27	0370
EG. 6 - 20 x 14	8757	20	14	49	59	7,5	29	11	27	0370
EG. 6 - 20 x 16	8758	20	16	49	59	7,5	29	11	27	0368
EG. 6 - 25 x 12	8759	25	12	54	66	8,5	32	13	32	0375
EG. 6 - 25 x 14	8760	25	14	54	66	8,5	32	13	32	0372
EG. 6 - 25 x 16	8761	25	16	54	66	8,5	32	13	32	0372
EG. 6 - 25 x 18	8762	25	18	54	66	8,5	32	13	32	0372
EG. 6 - 25 x 20	8763	25	20	54	66	8,5	32	13	32	0372
EG. 6 - 32 x 16	8764	32	16	64	76	8,5	42	13	39	0375
EG. 6 - 32 x 18	8765	32	18	64	76	8,5	42	13	39	0375
EG. 6 - 32 x 20	8766	32	20	64	76	8,5	42	13	39	0372
EG. 6 - 32 x 25	8767	32	25	64	76	8,5	42	13	39	0372
EG. 6 - 40 x 16	8768	40	16	74	88	9	51	14	48	0377
EG. 6 - 40 x 18	8769	40	18	74	88	9	51	14	48	0377
EG. 6 - 40 x 20	8770	40	20	74	88	9	51	14	48	0377
EG. 6 - 40 x 25	8771	40	25	74	88	9	51	14	48	0060
EG. 6 - 40 x 32	8772	40	32	74	88	9	51	14	48	0060
EG. 6 - 50 x 25	8773	50	25	84	98	9	61	14	59	0377
EG. 6 - 50 x 32	8774	50	32	84	98	9	61	14	59	0377
EG. 6 - 50 x 40	8775	50	40	84	98	9	61	14	59	0060
EG. 6 - 60 x 25	8881	60	25	94	108	9	71	14	69	0377
EG. 6 - 60 x 32	8882	60	32	94	108	9	71	14	69	0377
EG. 6 - 60 x 40	8883	60	40	94	108	9	71	14	69	0377
EG. 6 - 60 x 50	8884	60	50	94	108	9	71	14	69	0060



EG.7**BUSSOLE DI RIDUZIONE CON PROLUNGA**

REDUCTION SLEEVES WITH EXTENSION

HRC 55-58

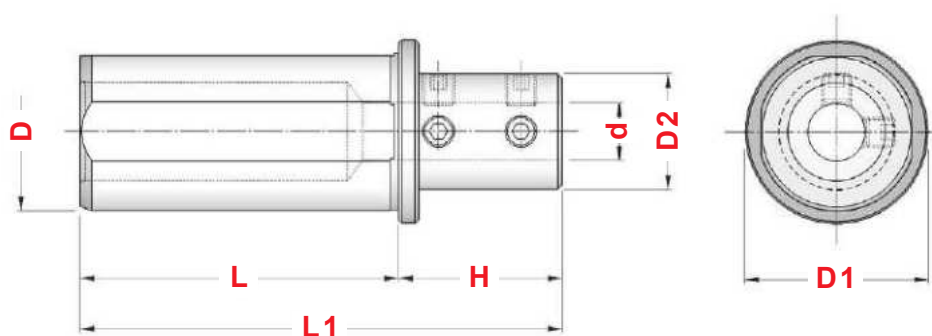

TIPO	Art.	D	d	L	H	L1	D1	D2	
EG.7 - 25 x 6	9567	25	6	54	30	84	30	20	0365
EG.7 - 25 x 8	9568	25	8	54	30	84	30	22	0370
EG.7 - 25 x 10	9569	25	10	54	30	84	30	24	0370
EG.7 - 25 x 12	9570	25	12	54	30	84	30	26	0370
EG.7 - 25 x 14	9571	25	14	54	30	84	30	28	0370
EG.7 - 25 x 16	9572	25	16	54	30	84	30	30	0370
EG.7 - 32 x 6	9573	32	6	64	30	94	37	20	0365
EG.7 - 32 x 8	9574	32	8	64	30	94	37	22	0370
EG.7 - 32 x 10	9575	32	10	64	30	94	37	24	0370
EG.7 - 32 x 12	9576	32	12	64	30	94	37	26	0370
EG.7 - 32 x 14	9577	32	14	64	30	94	37	28	0370
EG.7 - 32 x 16	9578	32	16	64	30	94	37	30	0370
EG.7 - 32 x 18	9579	32	18	64	30	94	37	32	0370
EG.7 - 32 x 20	9580	32	20	64	30	94	37	34	0370
EG.7 - 40 x 6	9581	40	6	74	40	114	45	20	0365
EG.7 - 40 x 8	9582	40	8	74	40	114	45	22	0370
EG.7 - 40 x 10	9583	40	10	74	40	114	45	24	0370
EG.7 - 40 x 12	9584	40	12	74	40	114	45	26	0370
EG.7 - 40 x 14	9585	40	14	74	40	114	45	28	0370
EG.7 - 40 x 16	9586	40	16	74	40	114	45	30	0370
EG.7 - 40 x 18	9587	40	18	74	40	114	45	32	0370
EG.7 - 40 x 20	9588	40	20	74	40	114	45	34	0372
EG.7 - 40 x 25	9589	40	25	74	40	114	45	39	0372
EG.7 - 50 x 12	9590	50	12	84	40	124	55	26	0370
EG.7 - 50 x 14	9591	50	14	84	40	124	55	28	0370
EG.7 - 50 x 16	9592	50	16	84	40	124	55	30	0370
EG.7 - 50 x 18	9593	50	18	84	40	124	55	32	0370
EG.7 - 50 x 20	9594	50	20	84	40	124	55	34	0372
EG.7 - 50 x 25	9595	50	25	84	40	124	55	39	0372



p.259

RZ

BUSSOLE DI RIDUZIONE TAGLIATE CON BATTUTA - TIPO RZ
SPLITTED REDUCTION SLEEVES WITH STOP - RZ TYPE

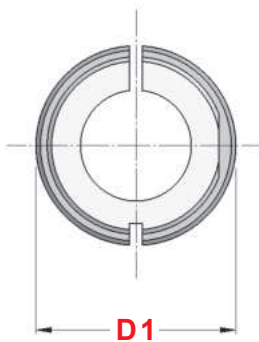
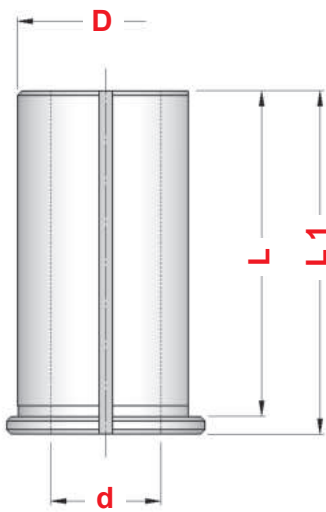

TIPO	Art.	D	d	L	L1	D1
RZ - 20 x 8	5920	20	8	36	40	25
RZ - 20 x 10	5921	20	10	36	40	25
RZ - 20 x 12	5922	20	12	36	40	25
RZ - 20 x 14	5923	20	14	36	40	25
RZ - 20 x 16	5924	20	16	36	40	25
RZ - 25 x 8	5925	25	8	46	50	30
RZ - 25 x 10	5926	25	10	46	50	30
RZ - 25 x 12	5927	25	12	46	50	30
RZ - 25 x 14	5928	25	14	46	50	30
RZ - 25 x 16	5929	25	16	46	50	30
RZ - 25 x 18	5930	25	18	46	50	30
RZ - 25 x 20	5931	25	20	46	50	30
RZ - 32 x 8	5932	32	8	56	60	37
RZ - 32 x 10	5933	32	10	56	60	37
RZ - 32 x 12	5934	32	12	56	60	37
RZ - 32 x 14	5935	32	14	56	60	37
RZ - 32 x 16	5936	32	16	56	60	37
RZ - 32 x 18	5937	32	18	56	60	37
RZ - 32 x 20	5938	32	20	56	60	37
RZ - 32 x 25	5939	32	25	56	60	37
RZ - 40 x 10	5941	40	10	74	78	45
RZ - 40 x 12	5942	40	12	74	78	45
RZ - 40 x 14	5943	40	14	74	78	45
RZ - 40 x 16	5944	40	16	74	78	45
RZ - 40 x 18	5945	40	18	74	78	45
RZ - 40 x 20	5946	40	20	74	78	45
RZ - 40 x 25	5947	40	25	74	78	45
RZ - 40 x 32	5948	40	32	74	78	45
RZ - 50 x 20	5951	50	20	84	88	55
RZ - 50 x 25	5952	50	25	84	88	55
RZ - 50 x 32	5953	50	32	84	88	55
RZ - 50 x 40	5954	50	40	84	88	55
RZ - 60 x 25	5956	60	25	88	92	65
RZ - 60 x 32	5957	60	32	88	92	65
RZ - 60 x 40	5958	60	40	88	92	65
RZ - 60 x 50	5959	60	50	88	92	65

Il doppio taglio aumenta la capacità elastica della bussola riducendo le vibrazioni dell'utensile

The double cut increases the bush elastic capacity reducing thus tool vibrations

E2.LAV**BUSSOLE TENERE LAVORABILI RETTIFICATE CON BATTUTA**

GRINDED NOT HARDENED REDUCTION SLEEVES WITH STOP

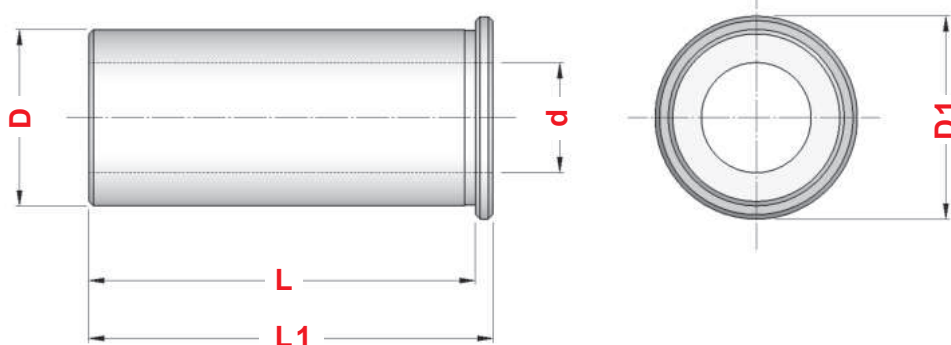

TIPO	Art.	D	d	L	L1	D1
E2.LAV - 25 x 8	1509	25	8	70	74	32
E2.LAV - 25 x 10	1511	25	10	70	74	32
E2.LAV - 25 x 12	1513	25	12	70	74	32
E2.LAV - 25 x 16	1517	25	16	70	74	32
E2.LAV - 25 x 20	1519	25	20	70	74	32
E2.LAV - 32 x 10	2284	32	10	88	92	36
E2.LAV - 32 x 12	2286	32	12	88	92	36
E2.LAV - 32 x 16	2289	32	16	88	92	36
E2.LAV - 32 x 20	2291	32	20	88	92	36
E2.LAV - 32 x 25	2293	32	25	88	92	36
E2.LAV - 40 x 12	2440	40	12	88	92	46
E2.LAV - 40 x 16	2442	40	16	88	92	46
E2.LAV - 40 x 20	2446	40	20	88	92	46
E2.LAV - 40 x 25	2460	40	25	88	92	46
E2.LAV - 40 x 32	2466	40	32	88	92	46

EG.R

BUSSOLE DI RIDUZIONE PER PORTABARENI

REDUCTION SLEEVES FOR BORING BAR HOLDERS

Figura 1



Figura 2



Utilizzabili con portabareni VDI, HSK, Poligonali, etc. La battuta è sagomata per evitare interferenza con gli ugelli di refrigerazione

Usable with boring bar holders VDI, HSK, Polygonal, etc. The stop is shaped to avoid interference with the refrigeration nozzles

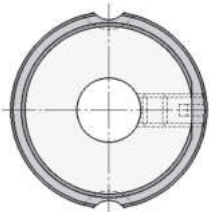
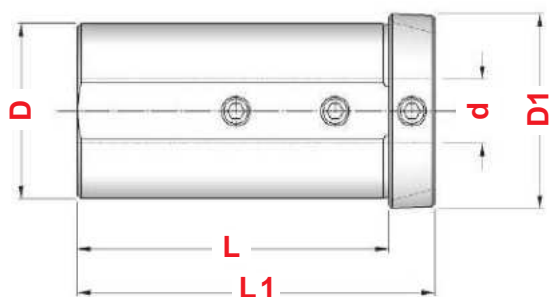
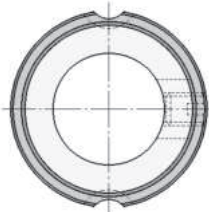
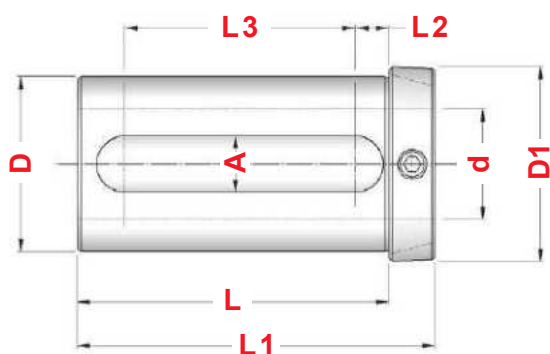
TIPO	Art.	D	d	L	L1	L2	L3	A	D1	Fig.
EG.R - 25 x 8	9600	25	8	51	61	-	-	-	30	1
EG.R - 25 x 10	9601	25	10	51	61	-	-	-	30	1
EG.R - 25 x 12	9602	25	12	51	61	-	-	-	30	1
EG.R - 25 x 14	9603	25	14	51	61	-	-	-	30	1
EG.R - 25 x 16	9604	25	16	51	61	8	34	13	30	2
EG.R - 25 x 18	9605	25	18	51	61	8	34	13	30	2
EG.R - 25 x 20	9606	25	20	51	61	8	34	13	30	2
EG.R - 32 x 8	9607	32	8	57,5	67,5	-	-	-	37	1
EG.R - 32 x 10	9608	32	10	57,5	67,5	-	-	-	37	1
EG.R - 32 x 12	9609	32	12	57,5	67,5	-	-	-	37	1
EG.R - 32 x 14	9610	32	14	57,5	67,5	-	-	-	37	1
EG.R - 32 x 16	9611	32	16	57,5	67,5	8	40	13	37	2
EG.R - 32 x 18	9612	32	18	57,5	67,5	8	40	13	37	2
EG.R - 32 x 20	9613	32	20	57,5	67,5	8	40	13	37	2
EG.R - 32 x 25	9614	32	25	57,5	67,5	8	40	13	37	2
EG.R - 40 x 8	9615	40	8	71	81	-	-	-	45	1
EG.R - 40 x 10	9616	40	10	71	81	-	-	-	45	1
EG.R - 40 x 12	9617	40	12	71	81	-	-	-	45	1
EG.R - 40 x 14	9618	40	14	71	81	-	-	-	45	1
EG.R - 40 x 16	9619	40	16	71	81	8	52	13	45	2
EG.R - 40 x 18	9620	40	18	71	81	8	52	13	45	2
EG.R - 40 x 20	9621	40	20	71	81	8	52	13	45	2
EG.R - 40 x 25	9622	40	25	71	81	8	52	13	45	2
EG.R - 40 x 32	9623	40	32	71	81	8	52	13	45	2

E 2.3**BUSSOLE DI RIDUZIONE A CONO MORSE SENZA BATTUTA**

MORSE TAPER REDUCTION SLEEVES WITHOUT STOP

Figura 1 **HRC 55-58**Figura 2 **HRC 55-58**

Figura 1



Figura 2



TIPO	Art.	D	CM	d	L	Fig.
E 2.3 - 20 x 1	5217	20	1	12,065	60	2
E 2.3 - 20 x 2	5218	20	2	17,780	90	1
E 2.3 - 25 x 1	5219	25	1	12,065	60	2
E 2.3 - 25 x 2	5220	25	2	17,780	90	1
E 2.3 - 32 x 1	5221	32	1	12,065	60	2
E 2.3 - 32 x 2	4322	32	2	17,780	90	1
E 2.3 - 32 x 3	4323	32	3	23,825	100	2
E 2.3 - 40 x 2	4324	40	2	17,780	90	1
E 2.3 - 40 x 3	4325	40	3	23,825	100	2
E 2.3 - 40 x 4	2857	40	4	31,267	120	2
E 2.3 - 50 x 2	4326	50	2	17,780	90	1
E 2.3 - 50 x 3	4327	50	3	23,825	100	2
E 2.3 - 50 x 4	4328	50	4	31,267	120	2
E 2.3 - 60 x 3	8891	60	3	23,825	160	1
E 2.3 - 60 x 4	8892	60	4	31,267	160	1
E 2.3 - 60 x 5	8893	60	5	44,399	160	2

E 2.G6**BUSSOLE DI RIDUZIONE A CONO MORSE CON BATTUTA**
MORSE TAPER REDUCTION SLEEVES WITH STOP

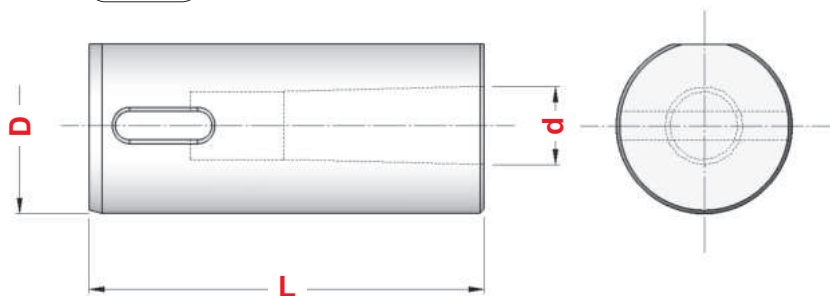
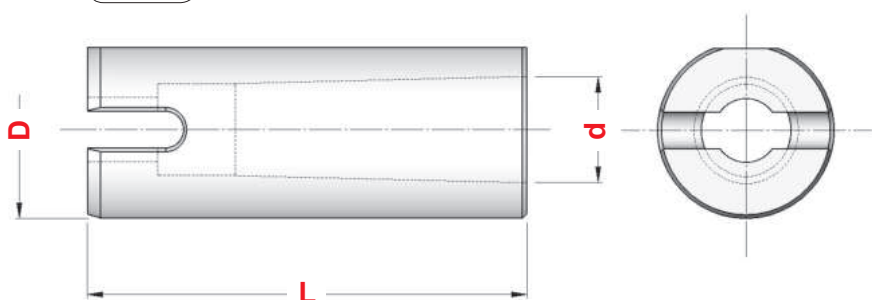
Figura 1	HRC 55-58
Figura 2	HRC 55-58

Figura 1



Figura 2



TIPO	Art.	D	CM	d	L	L1	D1	Fig.
E2.G6 - 20 x 1	1722	20	1	12,065	65	70	28	2
E2.G6 - 20 x 2	1723	20	2	17,780	70	75	28	2
E2.G6 - 25 x 1	1786	25	1	12,065	70	75	33	2
E2.G6 - 25 x 2	1787	25	2	17,780	70	75	33	2
E2.G6 - 25 x 3	1788	25	3	23,825	79	98	33	2
E2.G6 - 32 x 1	1376	32	1	12,065	85	90	40	1
E2.G6 - 32 x 2	1377	32	2	17,780	85	90	40	1
E2.G6 - 32 x 3	1378	32	3	23,825	95	100	40	2
E2.G6 - 40 x 2	3245	40	2	17,780	105	110	50	1
E2.G6 - 40 x 3	1232	40	3	23,825	105	110	50	1
E2.G6 - 40 x 4	5603	40	4	31,267	120	125	50	2
E2.G6 - 50 x 2	5961	50	2	17,780	125	130	63	1
E2.G6 - 50 x 3	5962	50	3	23,825	125	130	63	1
E2.G6 - 50 x 4	5963	50	4	31,267	125	130	63	1
E2.G6 - 60 x 3	8894	60	3	23,825	130	140	70	1
E2.G6 - 60 x 4	8895	60	4	31,267	130	140	70	1
E2.G6 - 60 x 5	8896	60	5	44,399	145	155	70	2

BG.1

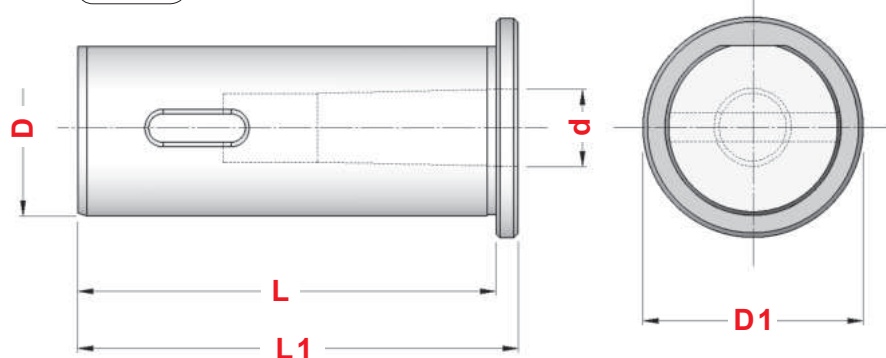
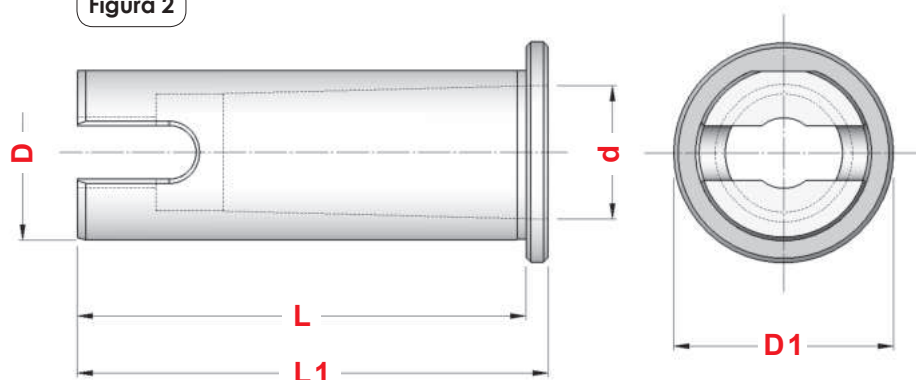
BUSSOLE DI RIDUZIONE PER BIGLIA etc.

REDUCTION SLEEVES FOR BIGLIA etc.

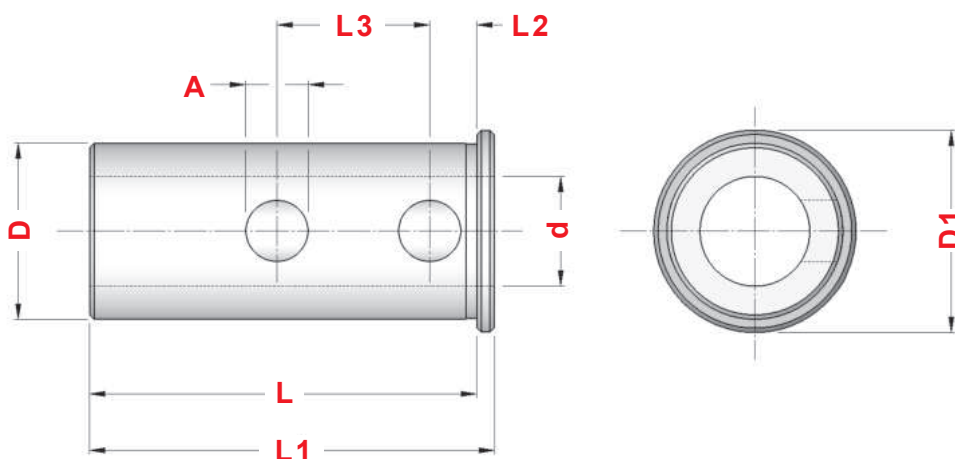

TIPO	Art.	D	d	L	L1	L2	L3	A	D1
BG.1 - 25 x 8	2823	25	8	70	74	7	28	9	32
BG.1 - 25 x 10	2824	25	10	70	74	7	28	9	32
BG.1 - 25 x 12	1064	25	12	70	74	7	28	9	32
BG.1 - 25 x 16	2198	25	16	70	74	7	28	9	32
BG.1 - 25 x 20	1212	25	20	70	74	7	28	9	32
BG.1 - 32 x 8	3229	32	8	88	92	9	35	14	36
BG.1 - 32 x 10	3230	32	10	88	92	9	35	14	36
BG.1 - 32 x 12	3231	32	12	88	92	9	35	14	36
BG.1 - 32 x 16	3232	32	16	88	92	9	35	14	36
BG.1 - 32 x 20	3233	32	20	88	92	9	35	14	36
BG.1 - 32 x 25	3234	32	25	88	92	9	35	14	36
BG.1 - 40 x 10	3240	40	10	88	92	9	35	14	46
BG.1 - 40 x 12	3239	40	12	88	92	9	35	14	46
BG.1 - 40 x 16	3238	40	16	88	92	9	35	14	46
BG.1 - 40 x 20	3235	40	20	88	92	9	35	14	46
BG.1 - 40 x 25	3236	40	25	88	92	9	35	14	46
BG.1 - 40 x 32	3237	40	32	88	92	9	35	14	46

BG.2

BUSSOLE DI RIDUZIONE CORTE PER BIGLIA etc.
SHORT REDUCTION SLEEVES FOR BIGLIA etc.

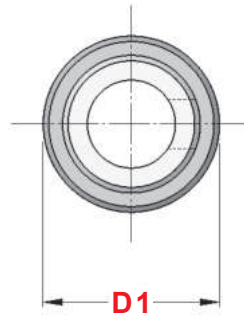
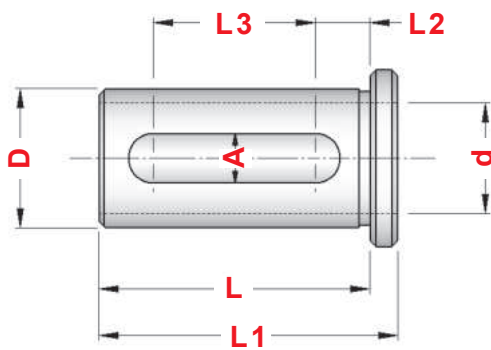

TIPO	Art.	D	d	L	L1	L2	L3	A	D1
BG.2 - 25 x 8	0022	25	8	49	54	10	29,5	9	32
BG.2 - 25 x 10	0024	25	10	49	54	10	29,5	9	32
BG.2 - 25 x 12	0025	25	12	49	54	10	29,5	9	32
BG.2 - 25 x 14	0091	25	14	49	54	10	29,5	9	32
BG.2 - 25 x 16	0026	25	16	49	54	10	29,5	9	32
BG.2 - 25 x 18	0092	25	18	49	54	10	29,5	9	32
BG.2 - 25 x 20	0034	25	20	49	54	10	29,5	9	32

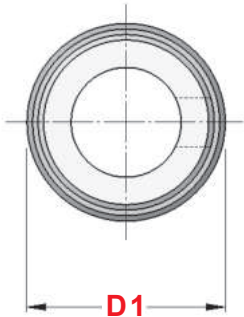
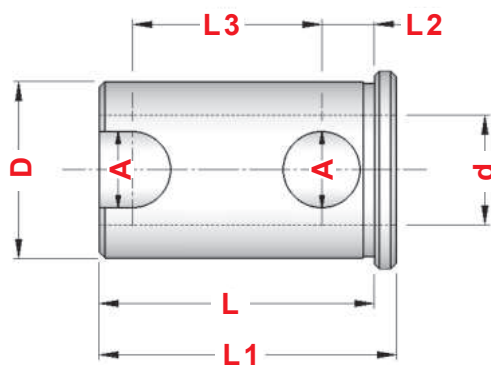

TIPO	Art.	D	d	L	L1	L2	L3	A	D1
BG.2 - 32 x 8	1083	32	8	50	54	9	35	14	36
BG.2 - 32 x 10	1236	32	10	50	54	9	35	14	36
BG.2 - 32 x 12	3246	32	12	50	54	9	35	14	36
BG.2 - 32 x 14	2604	32	14	50	54	9	35	14	36
BG.2 - 32 x 16	3247	32	16	50	54	9	35	14	36
BG.2 - 32 x 18	2605	32	18	50	54	9	35	14	36
BG.2 - 32 x 20	3248	32	20	50	54	9	35	14	36
BG.2 - 32 x 25	3249	32	25	50	54	9	35	14	36
BG.2 - 40 x 8	9558	40	8	50	54	9	35	14	44
BG.2 - 40 x 10	9559	40	10	50	54	9	35	14	44
BG.2 - 40 x 12	9560	40	12	50	54	9	35	14	44
BG.2 - 40 x 14	9561	40	14	50	54	9	35	14	44
BG.2 - 40 x 16	9562	40	16	50	54	9	35	14	44
BG.2 - 40 x 18	9563	40	18	50	54	9	35	14	44
BG.2 - 40 x 20	9564	40	20	50	54	9	35	14	44
BG.2 - 40 x 25	9565	40	25	50	54	9	35	14	44
BG.2 - 40 x 32	9566	40	32	50	54	9	35	14	44

DW.1

BUSSOLE DI RIDUZIONE CON GRANO SULLA BATTUTA PER DOOSAN DAEWOO etc.

REDUCTION SLEEVES WITH GRAIN ON STOP FOR DOOSAN DAEWOO etc.

Figura 1



Figura 2



TIPO	Art.	D	d	L	L1	L2	L3	A	D1	Fig.	G1	G2
DW.1- 32 x 10	8672	32	10	79	94	-	-	-	40	1	4972	0385
DW.1- 32 x 12	8673	32	12	79	94	-	-	-	40	1	4972	0385
DW.1- 32 x 16	8674	32	16	79	94	-	-	-	40	1	4972	0385
DW.1- 32 x 20	8675	32	20	79	94	9,5	60	11	40	2	0385	-
DW.1- 32 x 25	8676	32	25	79	94	9,5	60	11	40	2	0385	-
DW.1- 40 x 10	8916	40	10	74	89	-	-	-	48	1	0377	4972
DW.1- 40 x 12	8917	40	12	74	89	-	-	-	48	1	0377	4972
DW.1- 40 x 16	8918	40	16	74	89	-	-	-	48	1	0377	0060
DW.1- 40 x 20	8919	40	20	84	99	9	56	14	48	2	4972	-
DW.1- 40 x 25	8920	40	25	84	99	9	56	14	48	2	4972	-
DW.1- 40 x 32	8921	40	32	84	99	9	56	14	48	2	0385	-

DW.2

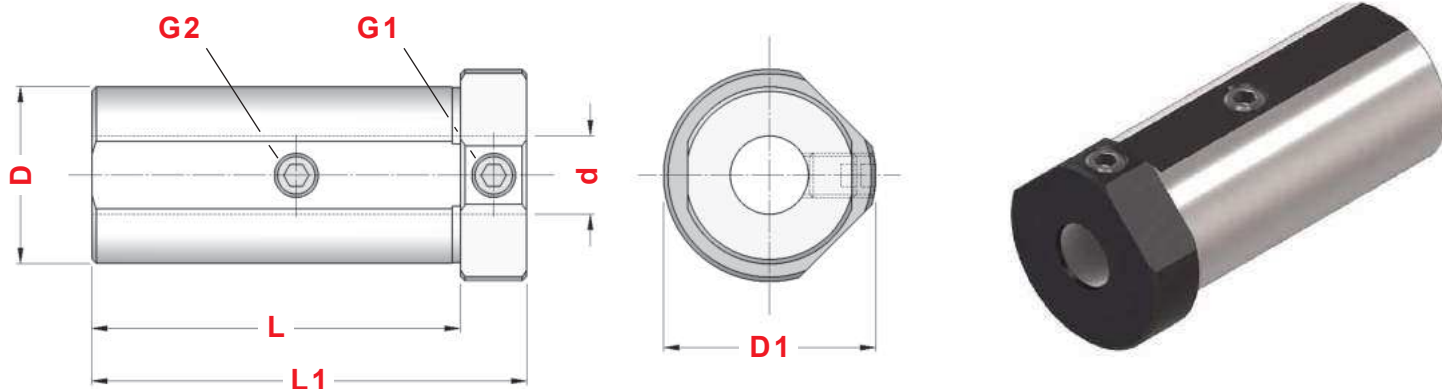
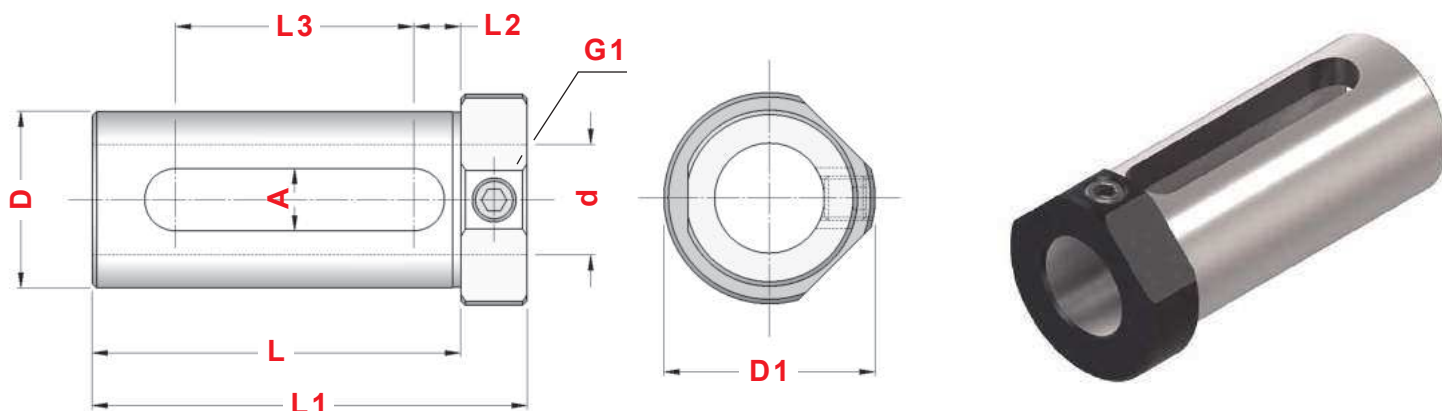
**BUSSOLE DI RIDUZIONE CON ASOLA E BATTUTA PER
DOOSAN DAEWOO etc.**
SLOTTED REDUCTION SLEEVES WITH STOP FOR DOOSAN DAEWOO etc.

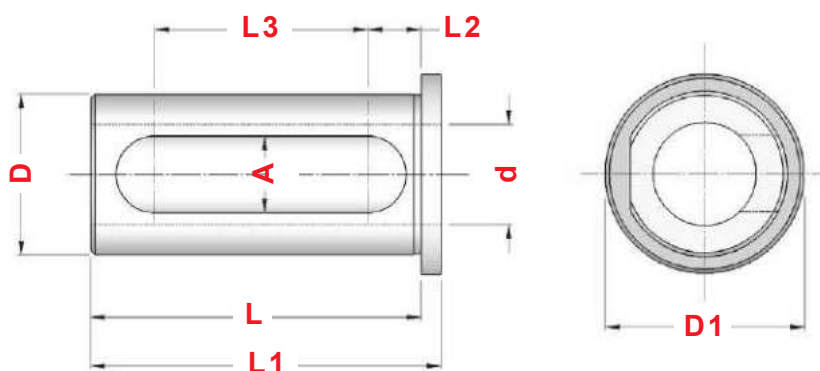

TIPO	Art.	D	d	L	L1	L2	L3	A	D1
DW.2- 20 x 8	8796	20	8	44	47	9,5	25	11	25
DW.2- 20 x 10	8797	20	10	44	47	9,5	25	11	25
DW.2- 20 x 12	8798	20	12	44	47	9,5	25	11	25
DW.2- 20 x 14	8880	20	14	44	47	9,5	25	11	25
DW.2- 20 x 16	8799	20	16	44	47	9,5	25	11	25
DW.2- 25 x 8	8557	25	8	54	57	8,5	33	13	30
DW.2- 25 x 10	8558	25	10	54	57	8,5	33	13	30
DW.2- 25 x 12	8559	25	12	54	57	8,5	33	13	30
DW.2- 25 x 14	8560	25	14	54	57	8,5	33	13	30
DW.2- 25 x 16	8561	25	16	54	57	8,5	33	13	30
DW.2- 25 x 18	8562	25	18	54	57	8,5	33	13	30
DW.2- 25 x 20	8563	25	20	54	57	8,5	33	13	30
DW.2- 32 x 8	8564	32	8	64	68	8,5	42	13	37
DW.2- 32 x 10	8565	32	10	64	68	8,5	42	13	37
DW.2- 32 x 12	8566	32	12	64	68	8,5	42	13	37
DW.2- 32 x 14	8567	32	14	64	68	8,5	42	13	37
DW.2- 32 x 16	8568	32	16	64	68	8,5	42	13	37
DW.2- 32 x 18	8569	32	18	64	68	8,5	42	13	37
DW.2- 32 x 20	8570	32	20	64	68	8,5	42	13	37
DW.2- 32 x 25	8571	32	25	64	68	8,5	42	13	37
DW.2- 40 x 12	8835	40	12	74	79	9	51	14	45
DW.2- 40 x 14	8836	40	14	74	79	9	51	14	45
DW.2- 40 x 16	8837	40	16	74	79	9	51	14	45
DW.2- 40 x 18	8838	40	18	74	79	9	51	14	45
DW.2- 40 x 20	8897	40	20	74	79	9	51	14	45
DW.2- 40 x 25	8898	40	25	74	79	9	51	14	45
DW.2- 40 x 32	8899	40	32	74	79	9	51	14	45

MZ.1

BUSSOLE DI RIDUZIONE PER MAZAK etc.

REDUCTION SLEEVES FOR MAZAK etc.

Figura 1	HRC 55-58
Figura 2	HRC 55-58

Figura 1





Figura 2



TIPO	Art.	D	d	L	L1	D1	Fig.	
MZ.1 - 32 x 8	8926	32	8	60	85	50	1	0371
MZ.1 - 32 x 10	8927	32	10	60	85	50	1	0371
MZ.1 - 32 x 12	8928	32	12	60	85	50	1	0375
MZ.1 - 32 x 16	8929	32	16	60	85	50	1	4971
MZ.1 - 32 x 20	8930	32	20	60	85	50	2	0375
MZ.1 - 32 x 25	8931	32	25	60	85	50	2	0375
MZ.1 - 40 x 8	5581	40	8	75	105	58	1	0371
MZ.1 - 40 x 10	5582	40	10	75	105	58	1	0371
MZ.1 - 40 x 12	5583	40	12	75	105	58	1	0375
MZ.1 - 40 x 16	5585	40	16	75	105	58	1	4971
MZ.1 - 40 x 20	5587	40	20	75	105	58	1	0183
MZ.1 - 40 x 25	5594	40	25	75	105	58	2	0021
MZ.1 - 40 x 32	5595	40	32	75	105	58	2	0021

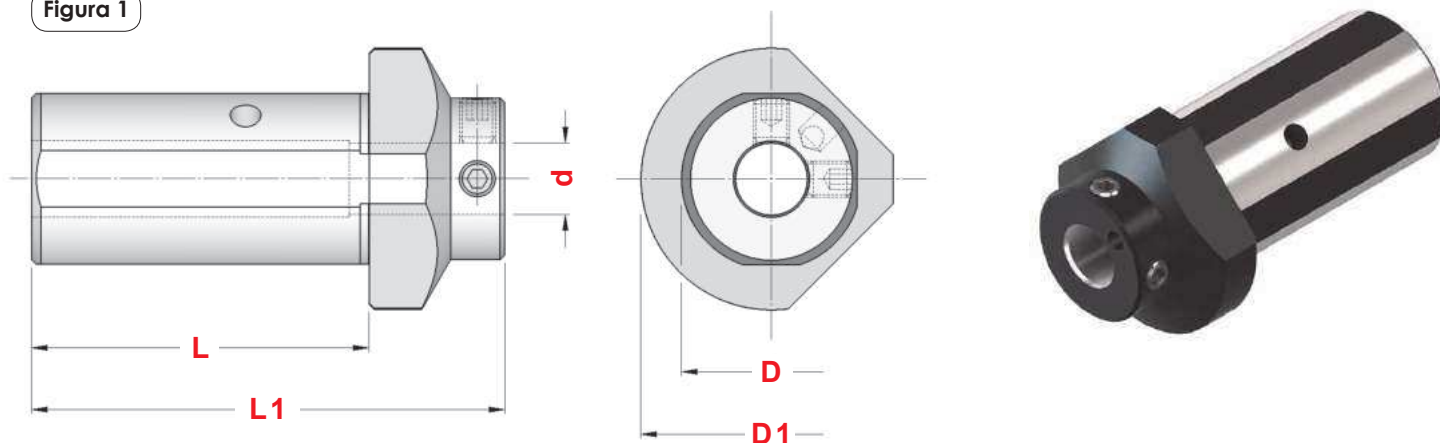
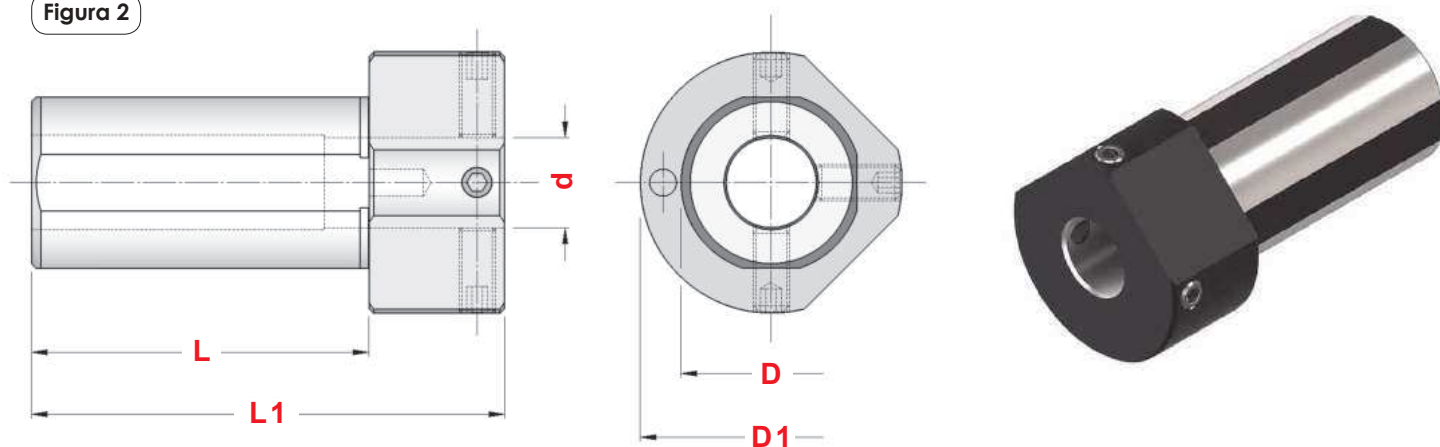

MZ.2

BUSSOLE DI RIDUZIONE CORTE PER MAZAK etc. SHORT REDUCTION SLEEVES FOR MAZAK etc.

HRC 55-58

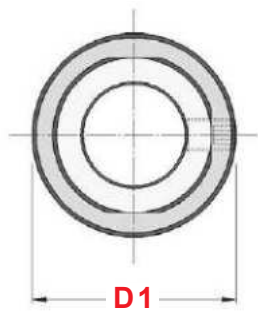
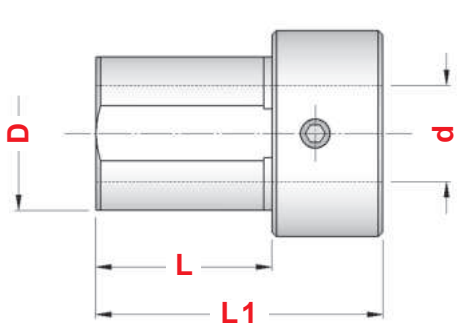

TIPO	Art.	D	d	L	L1	D1	
MZ.2 - 32 x 20	8932	32	20	40	65	42	4971
MZ.2 - 32 x 25	8933	32	25	40	65	42	0021
MZ.2 - 40 x 20	5596	40	20	40	65	50	0382
MZ.2 - 40 x 25	5597	40	25	40	65	50	0375
MZ.2 - 40 x 32	5598	40	32	40	65	50	4971



MZ.3

BUSSOLE DI RIDUZIONE A CONO MORSE PER MAZAK etc. MORSE TAPER REDUCTION SLEEVES FOR MAZAK etc.

Figura 1 HRC 55-58

Figura 2 HRC 55-58

Figura 1



Figura 2



TIPO	Art.	D	CM	d	L	L1	D1	Fig.
MZ.3 - 32 x 1	8983	32	1	12,065	54	66	42	2
MZ.3 - 32 x 2	8984	32	2	17,780	58	70	42	2
MZ.3 - 40 x 1	8985	40	1	12,065	97	105	50	1
MZ.3 - 40 x 2	8986	40	2	17,780	97	105	50	1
MZ.3 - 40 x 3	8987	40	3	23,825	97	105	50	2

MS.1

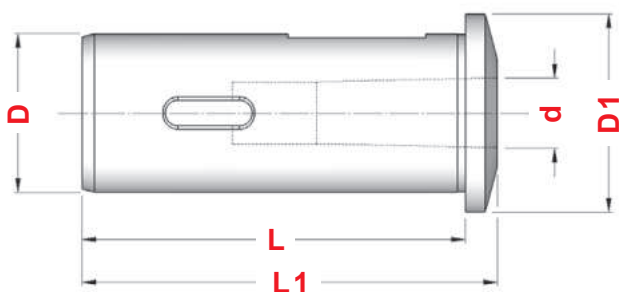
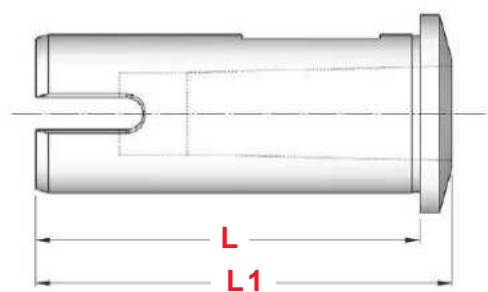
BUSSOLE DI RIDUZIONE PER DMG MORI SEIKI etc.

REDUCTION SLEEVES FOR DMG MORI SEIKI etc.

Figura 1



Figura 2



TIPO	Art.	D	d	L	L1	L2	L3	L4	A	D1	Fig.
MS.1 - 32 x 6	7035	32	6	79	86	10	29,5	-	10	38	1
MS.1 - 32 x 8	8941	32	8	79	86	10	29,5	-	10	38	1
MS.1 - 32 x 10	8942	32	10	79	86	10	29,5	-	10	38	1
MS.1 - 32 x 12	8943	32	12	79	86	10	29,5	29,5	10	38	2
MS.1 - 32 x 16	8944	32	16	79	86	10	29,5	29,5	10	38	2
MS.1 - 32 x 20	8945	32	20	79	86	10	29,5	29,5	10	38	2
MS.1 - 32 x 25	8946	32	25	79	86	10	29,5	29,5	10	38	2
MS.1 - 40 x 8	5900	40	8	89	96	10	33	-	12	46	1
MS.1 - 40 x 10	5901	40	10	89	96	10	33	-	12	46	1
MS.1 - 40 x 12	5902	40	12	89	96	10	33	-	12	46	1
MS.1 - 40 x 16	5903	40	16	89	96	10	33	33	12	46	2
MS.1 - 40 x 20	5904	40	20	89	96	10	33	33	12	46	2
MS.1 - 40 x 25	5905	40	25	89	96	10	33	33	12	46	2
MS.1 - 40 x 32	5906	40	32	89	96	10	33	33	12	46	2

MS.2

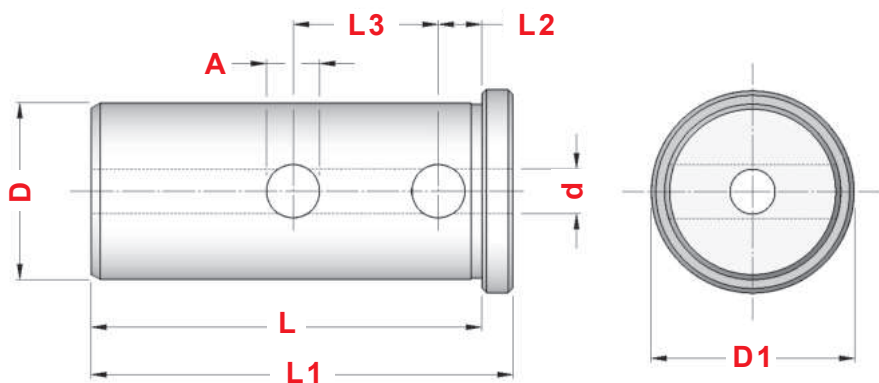
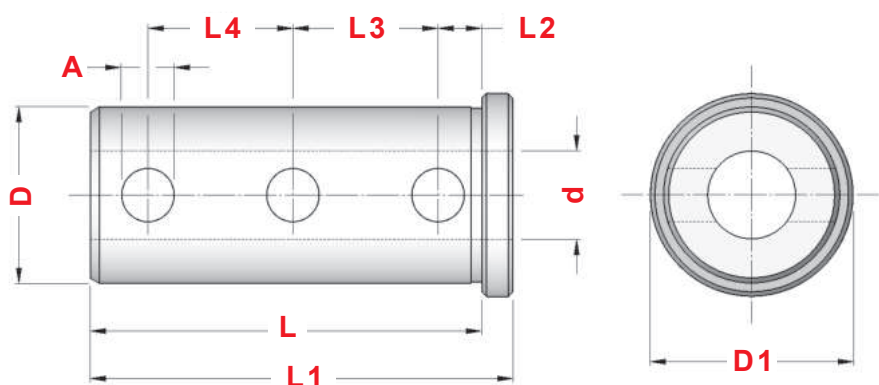
BUSSOLE DI RIDUZIONE CORTE PER DMG MORI SEIKI etc.
 SHORT REDUCTION SLEEVES FOR DMG MORI SEIKI etc.

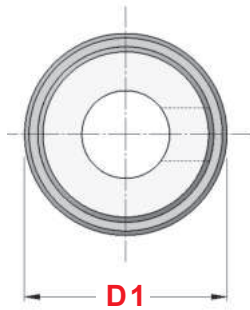
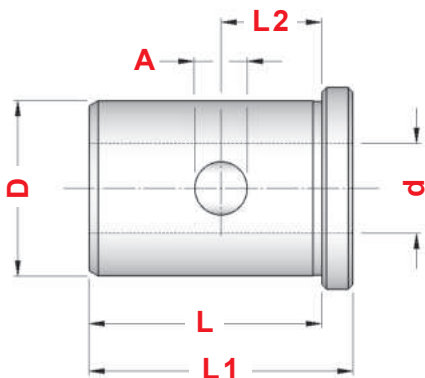

TIPO	Art.	D	d	L	L1	L2	A	D1
MS.2 - 32 x 16	8947	32	16	53	60	20	12	38
MS.2 - 32 x 20	8948	32	20	53	60	20	12	38
MS.2 - 32 x 25	8949	32	25	53	60	20	12	38
MS.2 - 40 x 16	8950	40	16	53	60	23	12	46
MS.2 - 40 x 20	8951	40	20	53	60	23	12	46
MS.2 - 40 x 25	8952	40	25	53	60	23	12	46
MS.2 - 40 x 32	8953	40	32	53	60	23	12	46

MS.2A

BUSSOLE DI RIDUZIONE CORTE CON PASSAGGIO REFRIGERANTE PER DMG MORI SEIKI etc.
 THROUGH COOLANT SHORT REDUCTION SLEEVES FOR DMG MORI SEIKI etc.

HRC 55-58

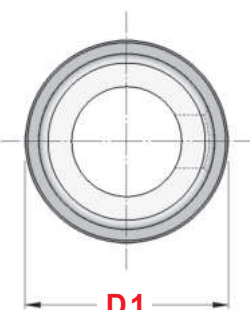
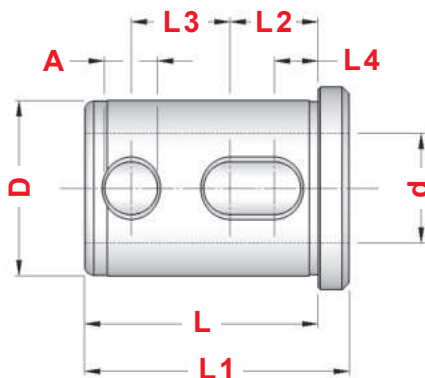

TIPO	Art.	D	d	L	L1	L2	L3	L4	A	D1
MS.2A - 40 x 16	8922	40	16	53	60	20	22,5	-	12	46
MS.2A - 40 x 20	8923	40	20	53	60	20	22,5	-	12	46
MS.2A - 40 x 25	8924	40	25	53	60	20	22,5	10	12	46
MS.2A - 40 x 32	8925	40	32	53	60	20	22,5	10	12	46

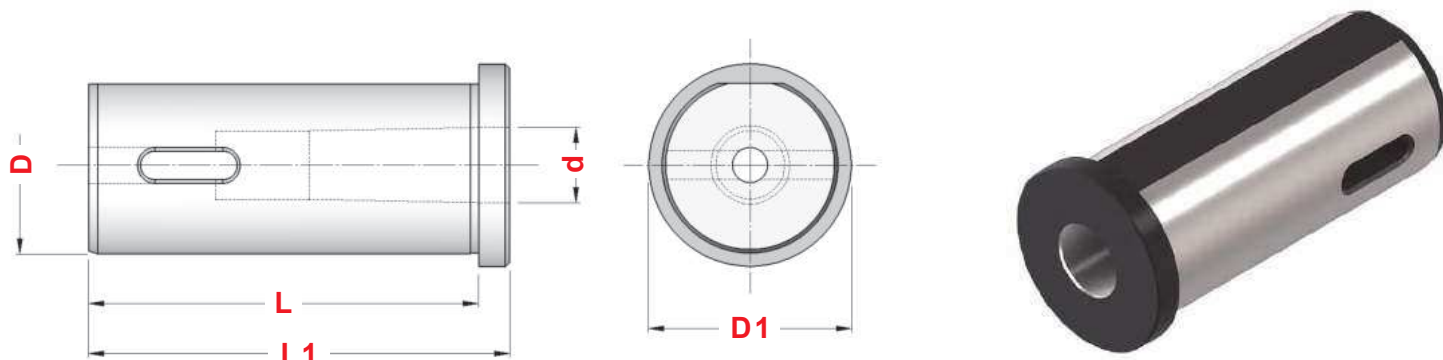
MS.4**BUSSOLE DI RIDUZIONE A CONO MORSE PER
DMG MORI SEIKI etc.***MORSE TAPER REDUCTION SLEEVES FOR DMG MORI SEIKI etc.***HRC 55-58**

TIPO	Art.	D	CM	d	L	L1	D1
MS.4 - 40 x 1	8958	40	1	12,065	89	96	46
MS.4 - 40 x 2	8959	40	2	17,780	89	96	46
MS.4 - 40 x 3	8960	40	3	23,825	89	108	46
MS.4 - 50 x 4	8961	50	4	31,267	89	135	56

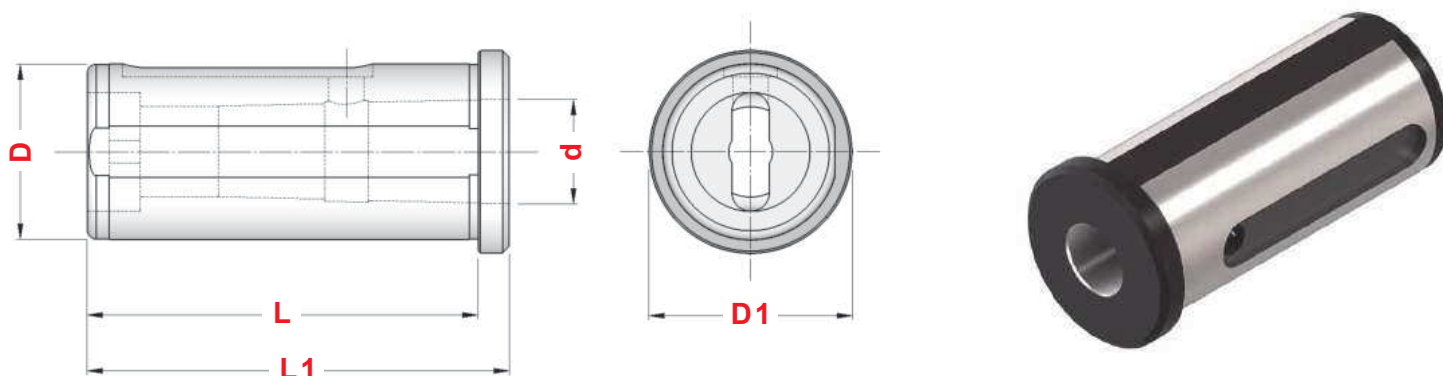
MS.4A**BUSSOLE DI RIDUZIONE A CONO MORSE CON PASSAGGIO REFRIGERANTE
PER DMG MORI SEIKI etc.***THROUGH COOLANT MORSE TAPER REDUCTION SLEEVES FOR DMG MORI SEIKI etc.***HRC 55-58**

TIPO	Art.	D	CM	d	L	L1	D1
MS.4A - 32 x 1	8868	32	1	12,065	78	85	40
MS.4A - 32 x 2	8869	32	2	17,780	78	85	40
MS.4A - 40 x 1	8870	40	1	12,065	89	96	46
MS.4A - 40 x 2	8871	40	2	17,780	89	96	46
MS.4A - 40 x 3	8872	40	3	23,825	89	96	46
MS.4A - 40 x 4	8873	40	4	31,267	109	116	46

MS.3A

BUSSOLE DI RIDUZIONE PROLUNGATE CON PASSAGGIO REFRIGERANTE PER DMG MORI SEIKI etc.

THROUGH COOLANT EXTENDED REDUCTION SLEEVES FOR DMG MORI SEIKI etc.

HRC 55-58

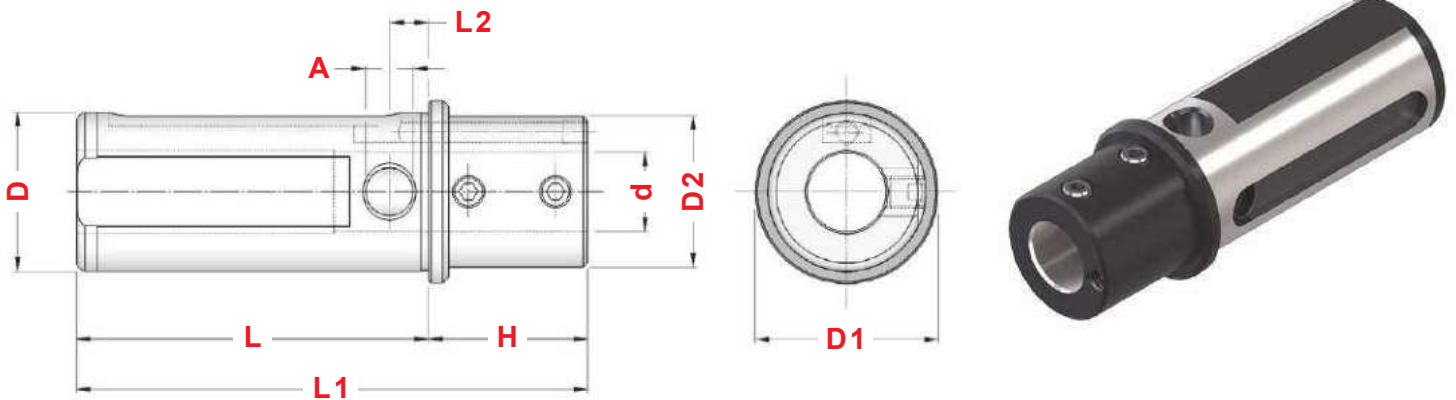

TIPO	Art.	D	d	L	H	L1	L2	A	D1	D2	
MS.3A - 40 x 8	8863	40	8	89	40	129	10	12	46	38	0375
MS.3A - 40 x 10	8864	40	10	89	40	129	10	12	46	38	0375
MS.3A - 40 x 12	8865	40	12	89	40	129	10	12	46	38	0375
MS.3A - 40 x 16	8866	40	16	89	40	129	10	12	46	38	4971
MS.3A - 40 x 20	8867	40	20	89	40	129	10	12	46	38	0021

NT.1

BUSSOLE DI RIDUZIONE PER NAKAMURA TOME etc.

REDUCTION SLEEVES FOR NAKAMURA TOME etc.

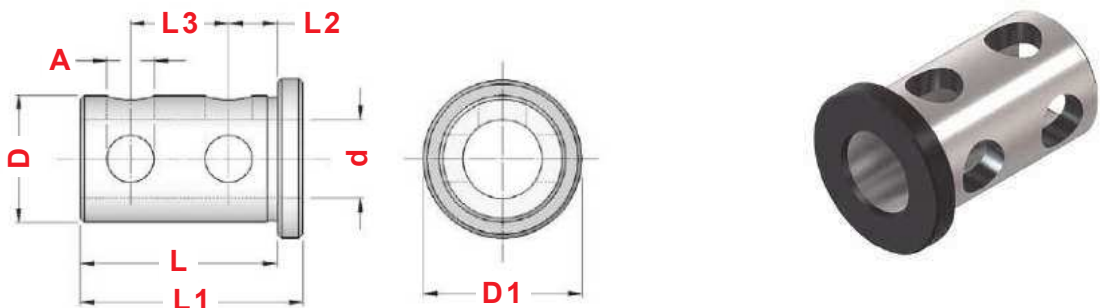

TIPO	Art.	D	d	L	L1	L2	L3	A	D1
NT.1 - 25 x 10	8876	25	10	40	45	10	20	10,5	32
NT.1 - 25 x 12	8877	25	12	40	45	10	20	10,5	32
NT.1 - 25 x 16	8878	25	16	40	45	10	20	10,5	32
NT.1 - 25 x 20	8879	25	20	40	45	10	20	10,5	32

OK.1

BUSSOLE DI RIDUZIONE PER OKUMA LT 10M / LT 200M etc.

REDUCTION SLEEVES FOR OKUMA LT10M/LT200M etc.

Figura 1



Figura 2



TIPO	Art.	D	d	L	L1	L2	L3	L4	A	D1	Fig.	G1	G2
OK.1 - 32 x 8	8900	32	8	57	69	-	-	-	-	40	1	0382	4971
OK.1 - 32 x 10	8901	32	10	57	69	-	-	-	-	40	1	0382	4971
OK.1 - 32 x 12	8902	32	12	57	69	-	-	-	-	40	1	0375	0021
OK.1 - 32 x 16	8904	32	16	59	71	11,5	35	4	13	40	2	0375	-
OK.1 - 32 x 20	8906	32	20	59	71	11,5	35	4	13	40	2	4971	-
OK.1 - 32 x 25	8907	32	25	59	71	11,5	35	4	13	40	2	0021	-

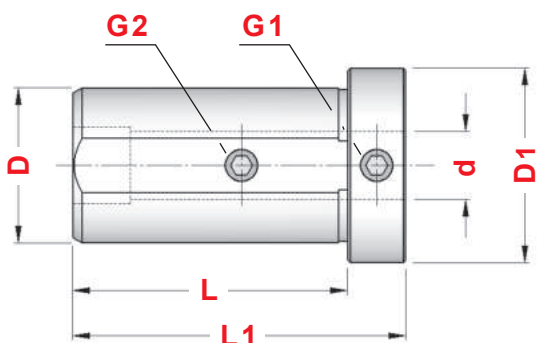
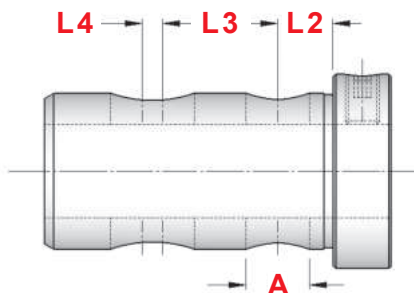

OK.2

BUSSOLE DI RIDUZIONE PER OKUMA LT 15M / LT 300M etc.

REDUCTION SLEEVES FOR OKUMA LT15M/LT300M etc.

Figura 1



Figura 2



TIPO	Art.	D	d	L	L1	L2	L3	L4	A	D1	Fig.	G1	G2
OK.2 - 40 x 12	8963	40	12	82	94	-	-	-	-	48	1	0382	0375
OK.2 - 40 x 16	8964	40	16	82	94	-	-	-	-	48	1	0382	4971
OK.2 - 40 x 20	8965	40	20	82	94	-	-	-	-	48	1	0375	0021
OK.2 - 40 x 25	8966	40	25	82	94	10	40	25	13	48	2	0375	-
OK.2 - 40 x 32	8967	40	32	82	94	10	40	25	13	48	2	0021	-

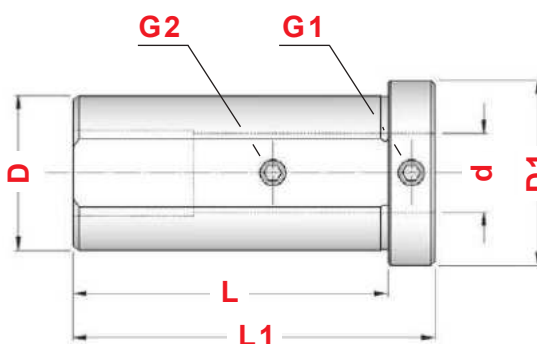
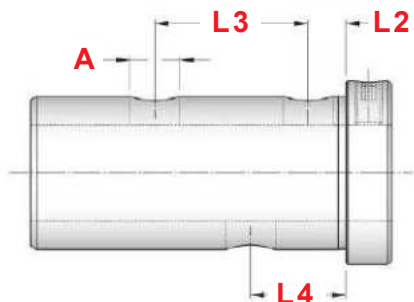

OK.4

BUSSOLE DI RIDUZIONE PER OKUMA LB 15 II etc.
REDUCTION SLEEVES FOR OKUMA LB 15 II etc.

Figura 1



Figura 2



TIPO	Art.	D	d	L	L1	L2	L3	L4	A	A1	D1	Fig.	G1	G2
OK.4 - 40 x 10	8971	40	10	80	95	-	-	-	-	-	48	1	0183	0375
OK.4 - 40 x 12	8972	40	12	80	95	-	-	-	-	-	48	1	0377	4972
OK.4 - 40 x 16	8973	40	16	80	95	-	-	-	-	-	48	1	0377	0060
OK.4 - 40 x 20	8974	40	20	80	95	-	-	-	-	-	48	1	4972	0385
OK.4 - 40 x 25	8975	40	25	68	80	11,5	42	15	16	13	48	2	4971	-
OK.4 - 40 x 32	8976	40	32	68	80	11,5	42	15	16	13	48	2	0021	-

OK.7

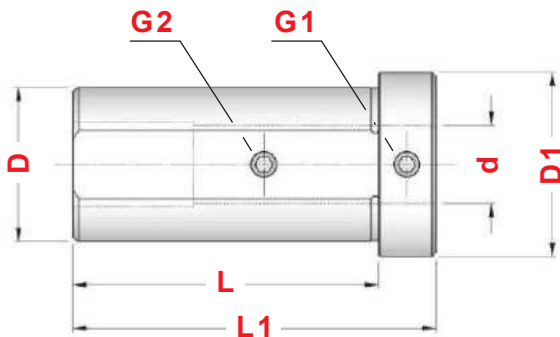
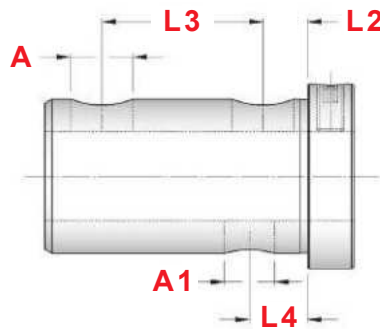
BUSSOLE DI RIDUZIONE PER OKUMA MACTURN 250 / MULTUS etc.
REDUCTION SLEEVES FOR OKUMA MACTURN 250 / MULTUS etc.

Figura 1



Figura 2



TIPO	Art.	D	d	L	L1	L2	L3	A	D1	Fig.	G1	G2
OK.7 - 40 x 10	8910	40	10	62	74	-	-	-	48	1	0382	0375
OK.7 - 40 x 12	8911	40	12	62	74	-	-	-	48	1	0382	0375
OK.7 - 40 x 16	8912	40	16	62	74	-	-	-	48	1	0382	0060
OK.7 - 40 x 20	8913	40	20	62	74	-	-	-	48	1	0375	0060
OK.7 - 40 x 25	8914	40	25	62	74	11,5	40	13	48	2	0375	-
OK.7 - 40 x 32	8915	40	32	62	74	11,5	40	13	48	2	0021	-

INDICE DELL' ATTACCO VDI - DIN 69880 (ISO 10889)

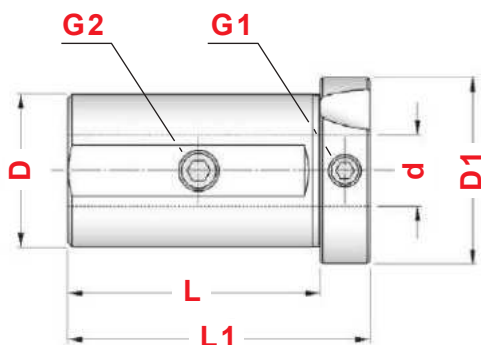
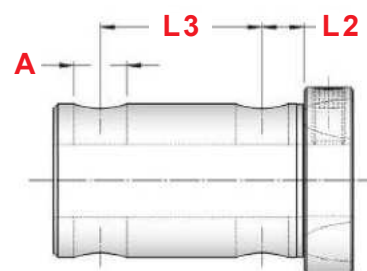
INDEX OF VDI - DIN 69880 SHANK (ISO 10889)

A1



pag. 315

A2



pag. 315

B1



pag. 316

B2



pag. 316

B3



pag. 317

B4



pag. 317

B5



pag. 318

B6



pag. 318

B7



pag. 319

B8



pag. 319

C1



pag. 320

C2



pag. 320

C3



pag. 321

C4



pag. 321

D1



pag. 322

D2



pag. 322

E1



pag. 324

E2



pag. 325

E2s



pag. 326

E7



pag. 327

E8



pag. 327

➔ segue
continue

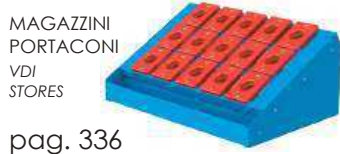

IMPIEGO DEI PORTAUTENSILI VDI RADIALI

USE OF RADIAL VDI TOOLHOLDERS

CON ROTAZIONE M4 DEL MANDRINO

WITH M4 SPINDLE ROTATION

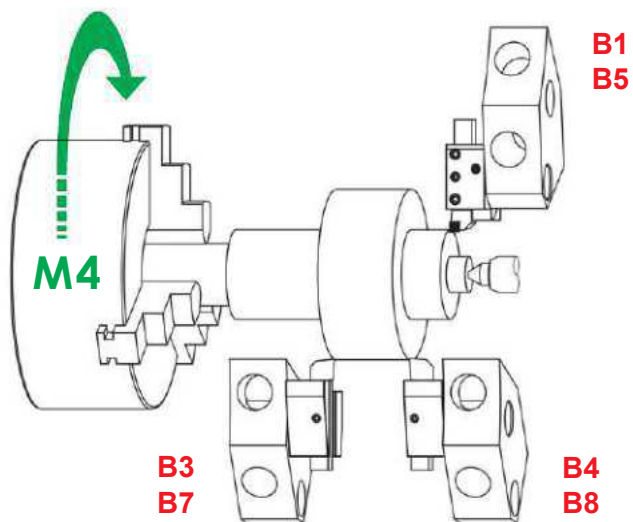

CON ROTAZIONE M3 DEL MANDRINO

WITH M3 SPINDLE ROTATION

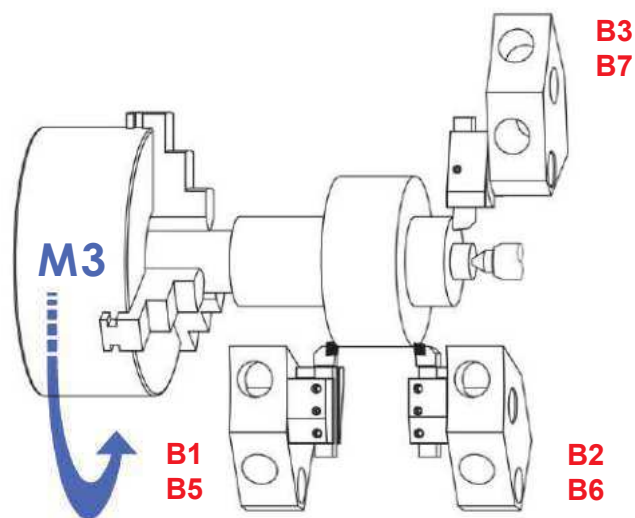

IMPIEGO DEI PORTAUTENSILI VDI ASSIALI

USE OF AXIAL VDI TOOLHOLDERS

CON ROTAZIONE M4 DEL MANDRINO

WITH M4 SPINDLE ROTATION

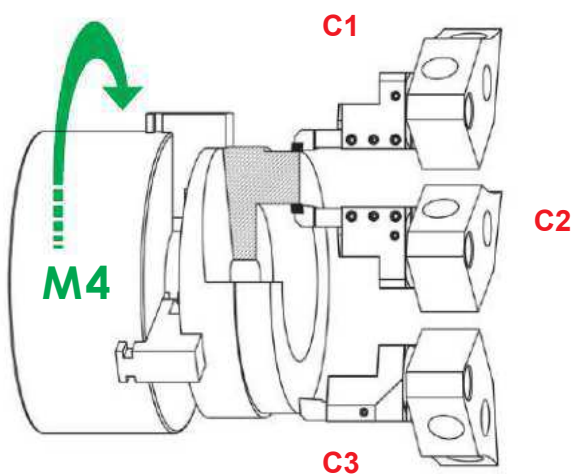

CON ROTAZIONE M3 DEL MANDRINO

WITH M3 SPINDLE ROTATION

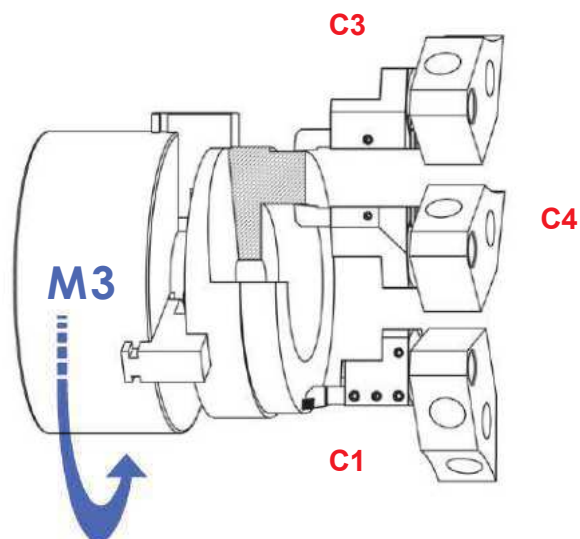

VDI DIN 69880 / ISO 10889	PORTAUTENSILI LAVORABILI A SEZIONE RETTANGOLARE RECTANGULAR SECTION BLANK TOOLHOLDERS
-------------------------------------	---

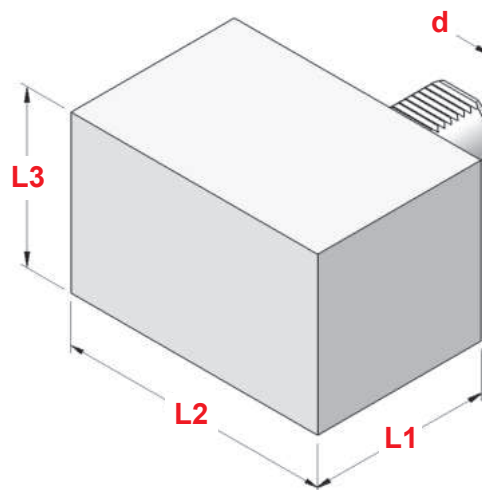
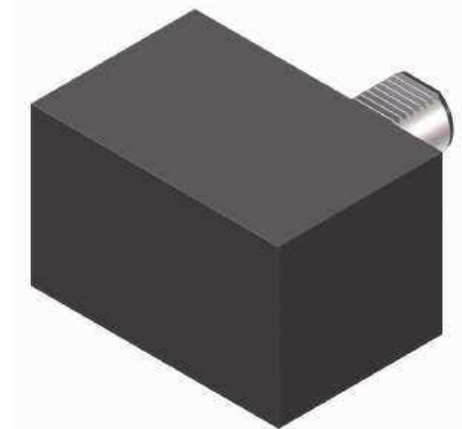

DIN ISO 10889-2 A1

TIPO	Art.	d	L1	L2	L3
A1- 30x85	5616	30	85	130	76
A1- 40x100	5635	40	100	151	96
A1- 50x125	5636	50	125	160	120
A1- 60x160	9356	60	160	165	125

VDI DIN 69880 / ISO 10889	PORTAUTENSILI LAVORABILI A SEZIONE TONDA ROUND SECTION BLANK TOOLHOLDERS
-------------------------------------	--

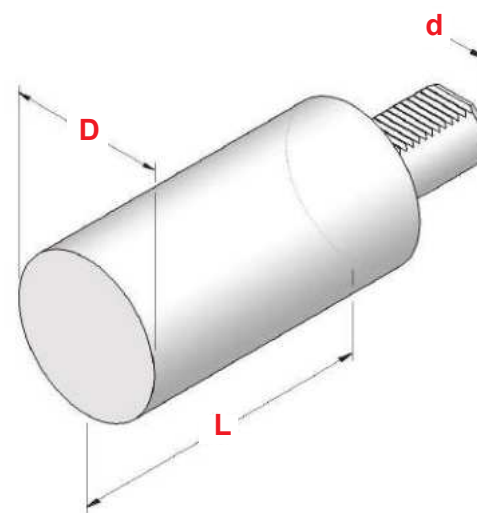

DIN ISO 10889-2 A2

TIPO	Art.	d	D	L
A2- 16x60	5602	16	40	60
A2- 20x70	5637	20	50	70
A2- 30x100	5615	30	68	100
A2- 30x240	5638			240
A2- 40x120	5639	40	83	120
A2- 40x320	5640			320
A2- 50x135	5641	50	98	135
A2- 50x400	5642			400
A2- 60x150	9357	60	123	150
A2- 60x480	9358			480

VDI
DIN 69880 / ISO 10889

PORTAUTENSILI CON SEDE TRASVERSALE DESTRI CORTI
RADIAL TOOL HOLDERS - RIGHT HAND - SHORT TYPE

B1

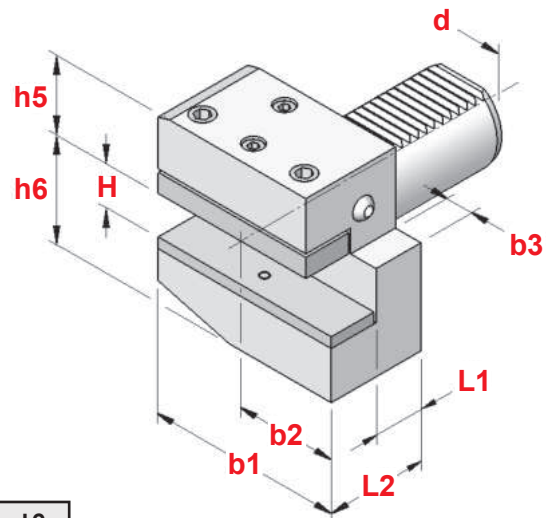

DIN ISO 10889-3 B1

TIPO	Art.	d	b1	b2	b3	H	h5	h6	L1	L2
B1 - 16x12x24	5605	16	42	23	5	12	20	22	13	24
B1 - 20x16x30	5643	20	55	30	7	16/12	25	30	16	30
B1 - 30x20x40	5617	30	70	35	10	20/16	28	38	22	40
B1 - 30x20x 60	5738	30	70	35	10	20/16	28	38	42	60
B1 - 40x25x44	5649	40	85	42,5	12,5	25/20	32,5	48	22	44
B1 - 50x32x55	5795	50	100	50	16	32/25	35	60	30	55
B1 - 60x32x60	9359	60	125	62,5	16	32/25	42,5	62,5	30	60

VDI
DIN 69880 / ISO 10889

PORTAUTENSILI CON SEDE TRASVERSALE SINISTRI CORTI
RADIAL TOOL HOLDERS - LEFT HAND - SHORT TYPE

B2

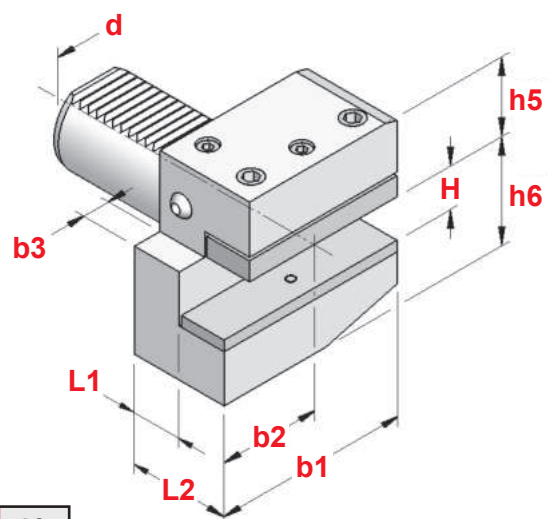

DIN ISO 10889-3 B2

TIPO	Art.	d	b1	b2	b3	H	h5	h6	L1	L2
B2 - 16x12x24	9324	16	42	23	5	12	20	22	13	24
B2 - 20x16x30	5650	20	55	30	7	16/12	25	30	16	30
B2 - 30x20x40	5624	30	70	35	10	20/16	28	38	22	40
B2 - 30x20x 60	5739	30	70	35	10	20/16	28	38	42	60
B2 - 40x25x44	5656	40	85	42,5	12,5	25/20	32,5	48	22	44
B2 - 50x32x55	5796	50	100	50	16	32/25	35	60	30	55
B2 - 60x32x60	9360	60	125	62,5	16	32/25	42,5	62,5	30	60

VDI
DIN 69880 / ISO 10889

PORTAUTENSILI CON SEDE TRASVERSALE ROVESCIA TI DESTRI CORTI
RADIAL UPSIDE-DOWN TOOLHOLDERS - RIGHT HAND - SHORT TYPE

B3

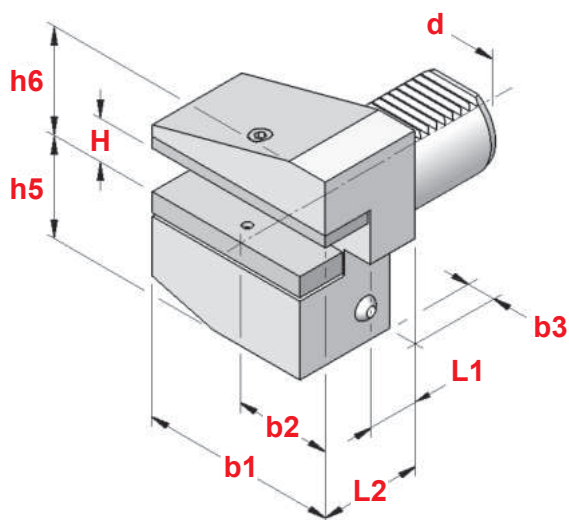

DIN ISO 10889-3 B3

TIPO	Art.	d	b1	b2	b3	H	h5	h6	L1	L2
B3 - 16x12x24	5654	16	42	23	5	12	20	22	13	24
B3 - 20x16x30	5657	20	55	30	7	16/12	25	30	16	30
B3 - 30x20x40	5621	30	70	35	10	20/16	35	38	22	40
B3 - 40x25x44	5663	40	85	42,5	12,5	25/20	40,5	48	22	44
B3 - 50x32x55	5797	50	100	50	16	32/25	50	60	30	55
B3 - 60x32x60	9361	60	125	62,5	16	32/25	62,5	62,5	30	60

VDI
DIN 69880 / ISO 10889

PORTAUTENSILI CON SEDE TRASVERSALE ROVESCIA TI SINISTRI CORTI
RADIAL UPSIDE-DOWN TOOLHOLDERS - LEFT HAND - SHORT TYPE

B4

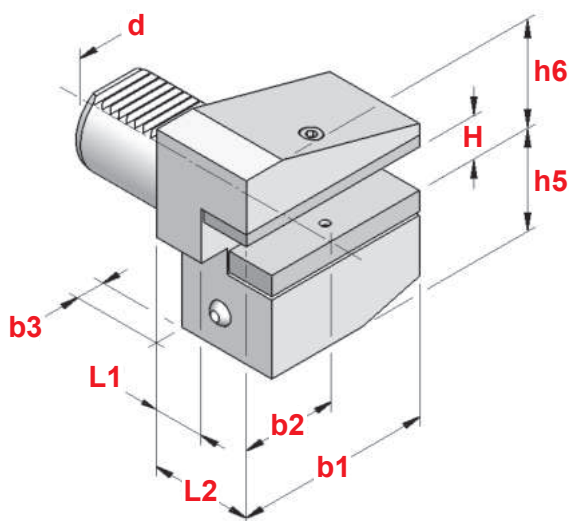

DIN ISO 10889-3 B4

TIPO	Art.	d	b1	b2	b3	H	h5	h6	L1	L2
B4 - 16x12x24	9326	16	42	23	5	12	20	22	13	24
B4 - 20x16x30	5664	20	55	30	7	16/12	25	30	16	30
B4 - 30x20x40	5627	30	70	35	10	20/16	35	38	22	40
B4 - 40x25x44	5670	40	85	42,5	12,5	25/20	42,5	48	22	44
B4 - 50x32x55	5798	50	100	50	16	32/25	50	60	30	55
B4 - 60x32x60	9362	60	125	62,5	16	32/25	62,5	62,5	30	60

VDI
DIN 69880 / ISO 10889

PORTAUTENSILI CON SEDE TRASVERSALE DESTRI LUNGHI
RADIAL TOOLHOLDERS - RIGHT HAND - LONG TYPE

B5

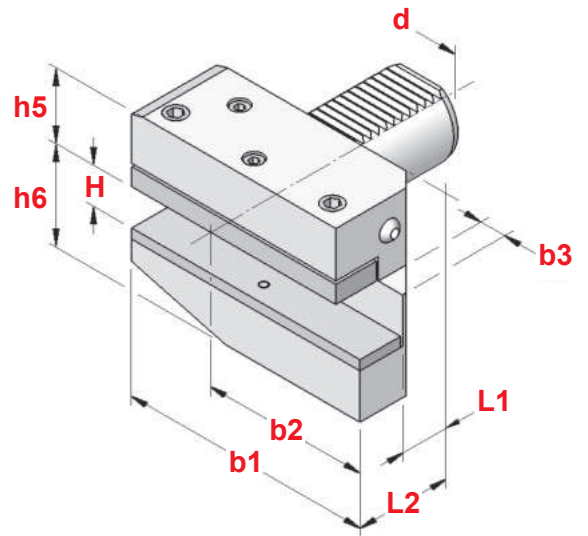

DIN ISO 10889-3 B5

TIPO	Art.	d	b1	b2	b3	H	h5	h6	L1	L2
B5 - 30x20x40	5620	30	100	65	10	20/16	28	38	22	40
B5 - 40x25x44	5677	40	118	75,5	12,5	25/20	32,5	48	22	44
B5 - 50x32x55	5802	50	130	80	16	32/25	35	60	30	55
B5 - 60x32x60	9363	60	145	82,5	16	32/25	42,5	62,5	30	60

VDI
DIN 69880 / ISO 10889

PORTAUTENSILI CON SEDE TRASVERSALE SINISTRI LUNGHI
RADIAL TOOLHOLDERS - LEFT HAND - LONG TYPE

B6

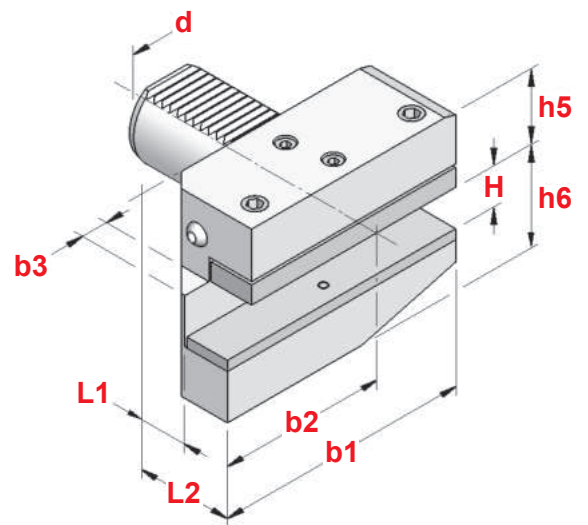

DIN ISO 10889-3 B6

TIPO	Art.	d	b1	b2	b3	H	h5	h6	L1	L2
B6 - 30x20x40	5619	30	100	65	10	20/16	28	38	22	40
B6 - 40x25x44	5684	40	118	75,5	12,5	25/20	32,5	48	22	44
B6 - 50x32x55	5791	50	130	80	16	32/25	35	60	30	55
B6 - 60x32x60	9364	60	145	82,5	16	32/25	42,5	62,5	30	60

VDI
DIN 69880 / ISO 10889

PORTAUTENSILI CON SEDE TRASVERSALE ROVESCIAI DESTRI LUNGH
RADIAL UPSIDE-DOWN TOOLHOLDERS - RIGHT HAND - LONG TYPE

B7

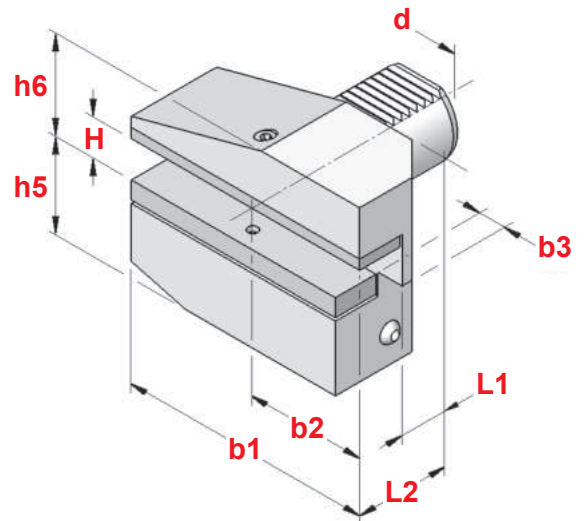

DIN ISO 10889-3 B7

TIPO	Art.	d	b1	b2	b3	H	h5	h6	L1	L2
B7 - 30x20x40	5689	30	100	65	10	20/16	35	38	22	40
B7 - 40x25x44	5692	40	118	75,5	12,5	25/20	42,5	48	22	44
B7 - 50x32x55	5803	50	130	80	16	32/25	50	60	30	55

VDI
DIN 69880 / ISO 10889

PORTAUTENSILI CON SEDE TRASVERSALE ROVESCIAI SINISTRI LUNGH
RADIAL UPSIDE-DOWN TOOLHOLDERS - LEFT HAND - LONG TYPE

B8

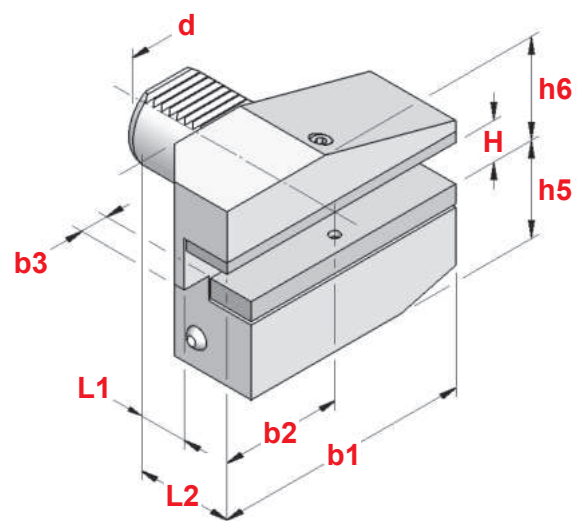

DIN ISO 10889-3 B8

TIPO	Art.	d	b1	b2	b3	H	h5	h6	L1	L2
B8 - 30x20x40	5697	30	100	65	10	20/16	35	38	22	40
B8 - 40x25x44	5700	40	118	75,5	12,5	25/20	42,5	48	22	44
B8 - 50x32x55	5804	50	130	80	16	32/25	50	60	30	55

VDI
DIN 69880 / ISO 10889

PORTAUTENSILI CON SEDE LONGITUDINALE DESTRI
AXIAL TOOLHOLDERS - RIGHT HAND

C1

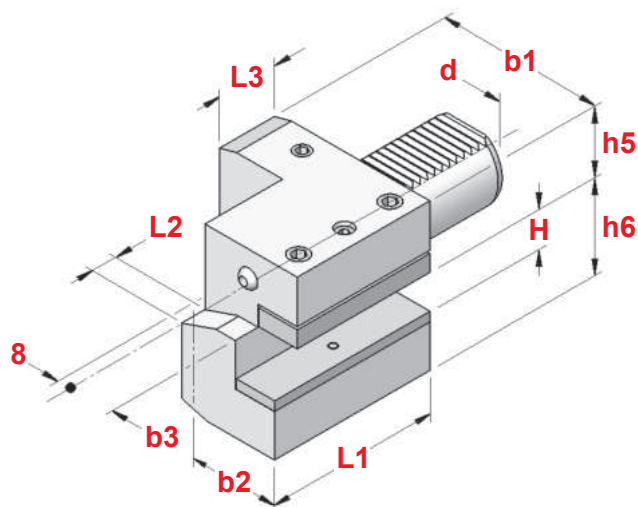

TIPO	Art.	d	b1	b2	b3	H	h5	h6	L1	L2	L3
C1- 20x16x55	5704	20	52	27	13	16/12	25	30	55	7	30
C1- 30x20x70	5703	30	70	35	17	20/16	28	38	70	10	30
C1- 40x25x85	5705	40	85	42,5	21	25/20	32,5	48	85	12,5	30
C1- 50x32x100	5806	50	100	50	26	32/25	35	60	100	16	40
C1- 60x32x125	9367	60	125	62,5	33	32/25	42,5	62,5	125	16	40

DIN ISO 10889-4 C1

VDI
DIN 69880 / ISO 10889

PORTAUTENSILI CON SEDE LONGITUDINALE SINISTRI
AXIAL TOOLHOLDERS - LEFT HAND

C2

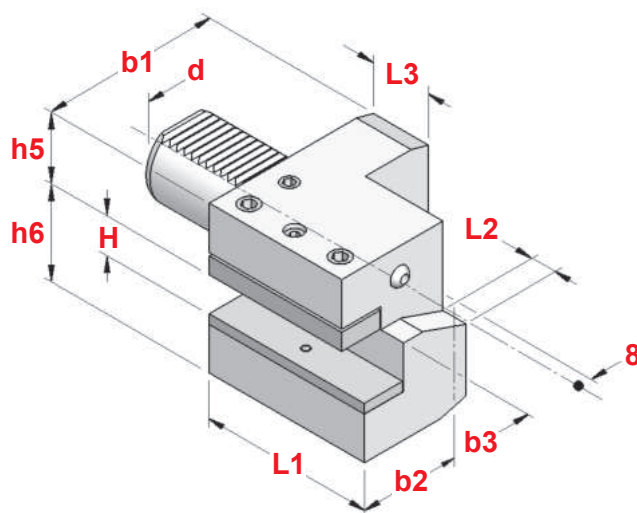

TIPO	Art.	d	b1	b2	b3	H	h5	h6	L1	L2	L3
C2- 20x16x55	5722	20	65	40	26	16/12	25	30	55	7	30
C2- 30x20x70	5724	30	76	41	23	20/16	28	38	70	10	30
C2- 40x25x85	5727	40	90	47,5	25,5	25/20	32,5	48	85	12,5	30
C2- 50x32x100	5807	50	105	55	30,5	32/25	35	60	100	16	40
C2- 60x32x125	9368	60	125	62,5	33	32/25	42,5	62,5	125	16	40

DIN ISO 10889-4 C2

VDI
DIN 69880 / ISO 10889

PORTAUTENSILI CON SEDE LONGITUDINALE ROVESCIA TI DESTRI
AXIAL UPSIDE-DOWN TOOLHOLDERS - RIGHT HAND

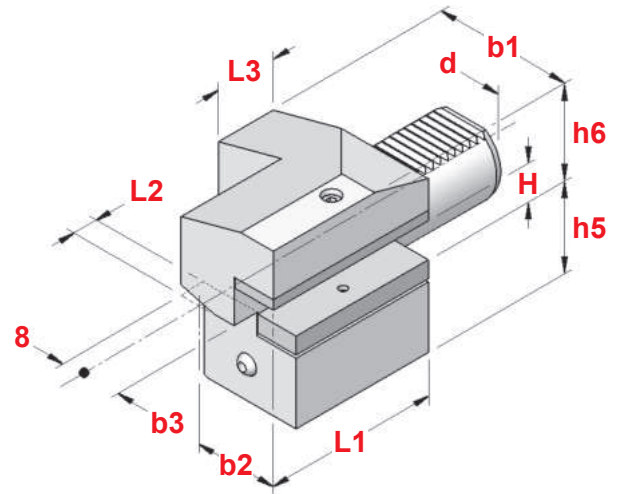

DIN ISO 10889-4 C3

TIPO	Art.	d	b1	b2	b3	H	h5	h6	L1	L2	L3
C3- 30x20x70	5740	30	70	35	17	20/16	35	38	70	10	30
C3- 40x25x85	5742	40	85	42,5	21	25/20	42,5	48	85	12,5	30
C3- 50x32x100	5808	50	100	50	26	32/25	50	60	100	16	40

VDI
DIN 69880 / ISO 10889

PORTAUTENSILI CON SEDE LONGITUDINALE ROVESCIA TI SINISTRI
AXIAL UPSIDE-DOWN TOOLHOLDERS - LEFT HAND

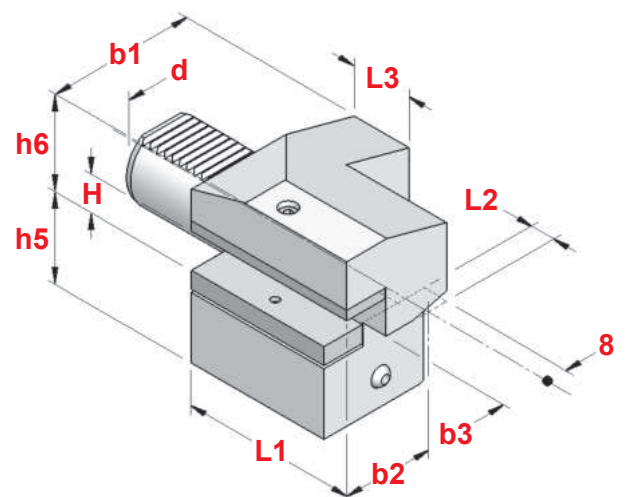

DIN ISO 10889-4 C4

TIPO	Art.	d	b1	b2	b3	H	h5	h6	L1	L2	L3
C4- 30x20x70	5618	30	76	41	23	20/16	35	38	70	10	30
C4- 40x25x85	5746	40	90	47,5	25,5	25/20	42,5	48	85	12,5	30
C4- 50x32x100	5809	50	105	55	30,5	32/25	50	60	100	16	40

VDI
DIN 69880 / ISO 10889

PORTAUTENSILI A PIU' SEDI RETTANGOLARI
TOOLHOLDERS WITH MULTIPLE SEATS

D1

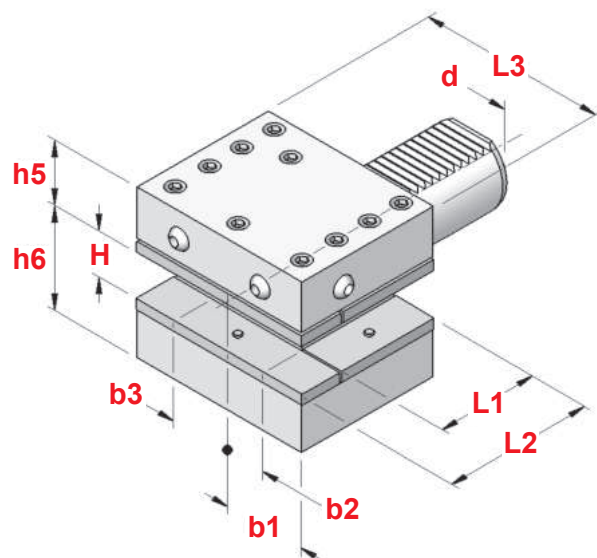

DIN ISO 10889-5 D1

TIPO	Art.	d	b1	b2	b3	H	h5	h6	L1	L2	L3
D1- 30x20x60	5748	30	35	17	23	20/16	28	38	42	60	76
D1- 40x25x72	5750	40	42,5	21	25,5	25/20	32,5	48	50	72	90
D1- 50x32x85	5810	50	50	26	30,5	32/25	35	60	60	85	105
D1- 60x32x110	9371	60	57,5	33	33	32/25	42,5	62,5	85	110	115

VDI
DIN 69880 / ISO 10889

PORTAUTENSILI A PIU' SEDI RETTANGOLARI ROVESCIA TI
UPSIDE-DOWN TOOLHOLDERS WITH MULTIPLE SEATS

D2

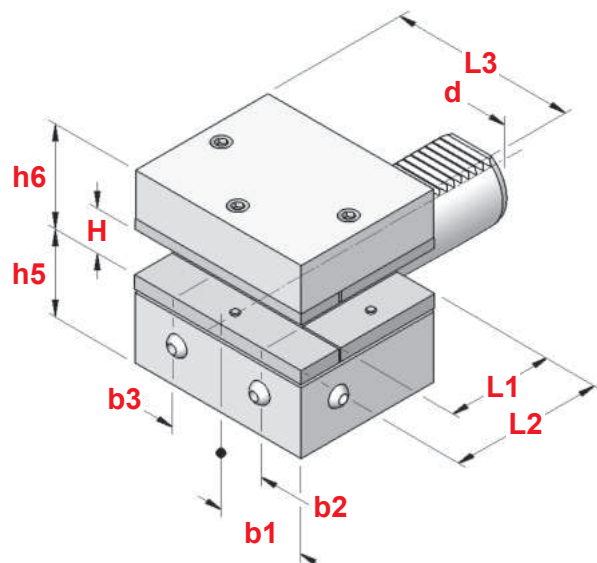

DIN ISO 10889-5 D2

TIPO	Art.	d	b1	b2	b3	H	h5	h6	L1	L2	L3
D2- 30x20x60	5752	30	35	17	23	20/16	35	38	42	60	76
D2- 40x25x72	5754	40	42,5	21	25,5	25/20	42,5	48	50	72	90
D2- 50x32x85	5811	50	50	26	30,5	32/25	50	60	60	85	105
D2- 60x32x110	9372	60	57,5	33	33	32/25	62,5	62,5	85	110	115

VDI

DIN 69880 / ISO 10889

FERMOBARRA ROTANTI REGOLABILI

ROTARY ADJUSTABLE BAR-STOP

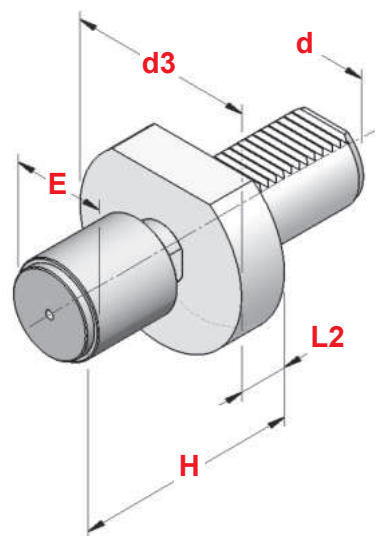
BS 1

TIPO	Art.	d	H	d3	L2	E
BS 1 - 20 x 34	7943	20	74 - 87	50	30	34
BS 1 - 20 x 42	7944	20	82 - 95	50	30	42
BS 1 - 30 x 42	7945	30	68 - 100	68	16	42
BS 1 - 30 x 56	7946	30	68 - 100	68	16	56
BS 1 - 40 x 42	7947	40	74 - 100	83	22	42
BS 1 - 40 x 56	7948	40	74 - 100	83	22	56

VDI

DIN 69880 / ISO 10889

FERMOBARRA ROTANTI REGOLABILI AMMORTIZZATI

DAMPED ROTARY ADJUSTABLE BAR-STOP

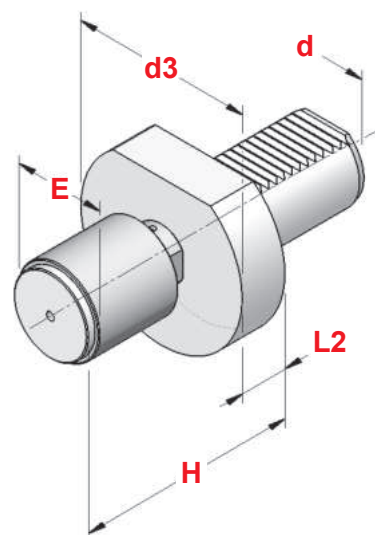
BS 2

TIPO	Art.	d	H	d3	L2	E
BS 2 - 20 x 34	5787	20	82 - 95	50	30	34
BS 2 - 20 x 42	5788	20	82 - 95	50	30	42
BS 2 - 30 x 42	5789	30	68 - 100	68	16	42
BS 2 - 30 x 56	3586	30	68 - 100	68	16	56
BS 2 - 40 x 42	5790	40	74 - 100	83	22	42
BS 2 - 40 x 56	3587	40	74 - 100	83	22	56

CARATTERISTICHE : a differenza del normale fermobarra rotante, nel modello ammortizzato, oltre al cuscinetto radiale ed al reggispira, è presente una serie di molle a tazza per meglio assorbire eventuali urti della barra

CHARACTERISTICS: unlike normal rotary bar stop, inside damped model, besides radial bearing and thrust bearing, there is a set of spring washers in order to absorb well any bar shoves

VDI
DIN 69880 / ISO 10889

PORTAUTENSILI CON REFRIGERAZIONE INTERNA PER PUNTE AD INSERTI
INDEXABLE DRILL HOLDERS WITH INSIDE COOLING

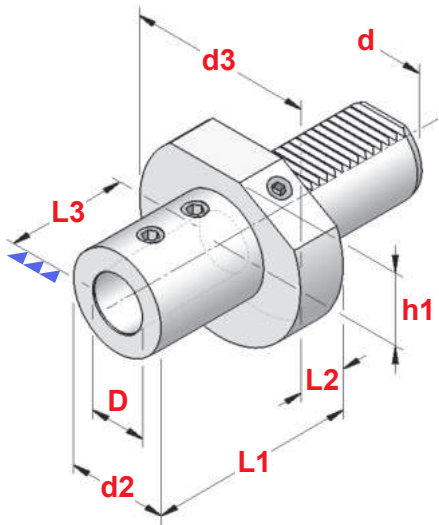

DIN ISO 10889-6 E1

TIPO	Art.	d	D	d2	d3	h1	L1	L2	L3	
E1 - 20x16	5728	20	16	36	50	-	64	18	51	0403
E1 - 20x20	5729	20	20	40	50	-	67	18	54	0403
E1 - 20x25	5730	20	25	45	50	-	71	18	59	0417
E1 - 30x6	9347	30	6	36	68	28	64	22	46	4970
E1 - 30x8	9348	30	8	36	68	28	64	22	46	4970
E1 - 30x10	9349	30	10	36	68	28	64	22	46	4970
E1 - 30x12	9350	30	12	36	68	28	64	22	55	0403
E1 - 30x16	5731	30	16	36	68	28	64	22	51	0403
E1 - 30x20	5732	30	20	40	68	28	67	22	54	0403
E1 - 30x25	5733	30	25	45	68	28	71	22	59	0417
E1 - 30x32	5734	30	32	52	68	28	75	22	63	0417
E1 - 30x40	5735	30	40	68	68	28	85	-	73	0493
E1 - 40x6	9351	40	6	36	83	32,5	64	22	46	4970
E1 - 40x8	9352	40	8	36	83	32,5	64	22	46	4970
E1 - 40x10	9353	40	10	36	83	32,5	64	22	46	4971
E1 - 40x12	9354	40	12	36	83	32,5	64	22	55	4971
E1 - 40x16	5833	40	16	36	83	32,5	64	22	51	0403
E1 - 40x20	5834	40	20	40	83	32,5	67	22	54	0403
E1 - 40x25	5835	40	25	45	83	32,5	75	22	59	0417
E1 - 40x32	5836	40	32	52	83	32,5	75	22	63	0417
E1 - 40x40	5837	40	40	65	83	32,5	90	22	73	0493
E1 - 40x50	9355	40	50	75	83	32,5	100	22	83	0493
E1 - 50x20	5839	50	20	40	98	35	67	30	54	0403
E1 - 50x25	5840	50	25	45	98	35	80	30	59	0417
E1 - 50x32	5841	50	32	52	98	35	80	30	63	0417
E1 - 50x40	5842	50	40	65	98	35	90	30	73	0493
E1 - 50x50	5843	50	50	75	98	35	100	30	83	0493
E1 - 60x32	9376	60	32	52	123	42,5	80	30	63	0417
E1 - 60x40	9377	60	40	65	123	42,5	90	30	73	0493
E1 - 60x50	9378	60	50	75	123	42,5	100	30	83	0493



VDI
DIN 69880 / ISO 10889

PORTABARENI CON REFRIGERAZIONE INTERNA E ESTERNA
BORING BAR HOLDERS WITH INSIDE AND OUTSIDE COOLING



E2

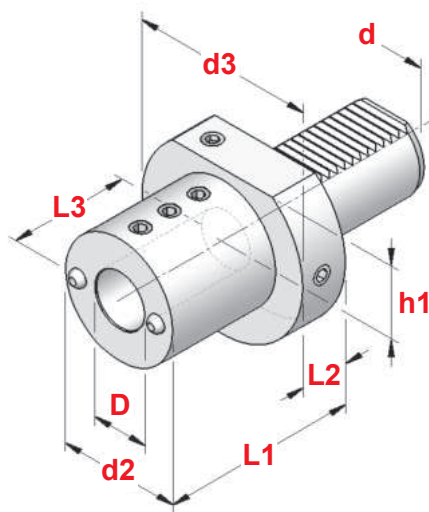

DIN ISO 10889-6 E2

TIPO	Art.	d	D	d2	d3	h1	L1	L2	L3	
E2-16x6	9336	16	6	32	40	18	44	13	34	0371
E2-16x8	9337	16	8	32	40	18	44	13	34	0371
E2-16x10	9338	16	10	32	40	18	44	13	34	0371
E2-16x12	9339	16	12	40	40	18	44	-	34	0375
E2-16x16	9340	16	16	40	40	18	44	-	34	0375
E2-20x6	5725	20	6	40	50	-	50	18	42	0208
E2-20x8	5762	20	8	40	50	-	50	18	42	0208
E2-20x10	5763	20	10	40	50	-	50	18	42	0208
E2-20x12	5764	20	12	40	50	-	50	18	42	0375
E2-20x16	5765	20	16	40	50	-	50	18	42	0375
E2-20x20	5766	20	20	50	50	-	50	-	42	0375
E2-20x25	5767	20	25	50	50	-	60	-	52	0375
E2-30x6	5741	30	6	55	68	28	60	22	42	0248
E2-30x8	5768	30	8	55	68	28	60	22	51	0248
E2-30x10	5769	30	10	55	68	28	60	22	51	0248
E2-30x12	5631	30	12	55	68	28	60	22	51	0183
E2-30x16	5632	30	16	55	68	28	60	22	51	0183
E2-30x20	5633	30	20	55	68	28	60	22	51	0382
E2-30x25	5622	30	25	60	68	28	60	22	51	0382
E2-30x32	5629	30	32	68	68	28	75	-	61	0382
E2-30x40	5628	30	40	68	68	28	88	-	76	0382
E2-40x6	5747	40	6	55	83	32,5	75	22	42	0248
E2-40x8	5749	40	8	55	83	32,5	75	22	61	0248
E2-40x10	5751	40	10	55	83	32,5	75	22	61	0183
E2-40x12	5770	40	12	55	83	32,5	75	22	61	0183
E2-40x16	5771	40	16	55	83	32,5	75	22	61	0186
E2-40x20	5772	40	20	55	83	32,5	75	22	61	0186
E2-40x25	5773	40	25	55	83	32,5	75	22	61	0377
E2-40x32	5774	40	32	83	83	32,5	75	-	61	0186
E2-40x40	5775	40	40	83	83	32,5	90	-	76	0377
E2-40x50	5785	40	50	83	83	32,5	100	-	86	0260
E2-50x12	5805	50	12	68	98	35	90	30	61	0249
E2-50x16	5812	50	16	68	98	35	90	30	76	0250
E2-50x20	5813	50	20	68	98	35	90	30	76	0257
E2-50x25	5814	50	25	68	98	35	90	30	76	0257
E2-50x32	5815	50	32	68	98	35	90	30	76	0277
E2-50x40	5816	50	40	98	98	35	90	-	76	4973
E2-50x50	5817	50	50	98	98	35	100	-	86	0260
E2-60x20	9380	60	20	68	123	42,5	90	30	76	0257
E2-60x25	9381	60	25	68	123	42,5	90	30	76	0257
E2-60x32	9382	60	32	68	123	42,5	90	30	76	0277
E2-60x40	9383	60	40	98	123	42,5	90	30	76	0277
E2-60x50	9384	60	50	98	123	42,5	100	30	86	0277

Bussole di riduzione
Reduction sleeves



p.297



p.337



p.259

VDI
DIN 69880 / ISO 10889

**PORTABARENI CON REFRIGERAZIONE ESTERNA - INTERNA
A CHIUSURA ELASTICA**
ELASTIC GRIPPING BORING BAR HOLDERS WITH OUTSIDE - INSIDE COOLING



E2s



TIPO	Art.	d	D	d2	d3	h1	L1	L2	L3	
E2 S - 30x 8	7952	30	8	34	68	28	75	22	65	0371
E2 S - 30x 10	7953	30	10	38	68	28	75	22	65	0375
E2 S - 30x 12	7954	30	12	38	68	28	75	22	65	0375
E2 S - 30x 16	7955	30	16	42	68	28	75	22	70	4972
E2 S - 30x 20	7956	30	20	42	68	28	75	22	66	4972
E2 S - 30x 25	7957	30	25	48	68	28	75	22	66	4972
E2 S - 30x 32	7958	30	32	56	68	28	75	22	65	4972
E2 S - 40x 8	7961	40	8	34	83	32,5	75	22	65	0371
E2 S - 40x 10	7962	40	10	38	83	32,5	75	22	65	0375
E2 S - 40x 12	7963	40	12	38	83	32,5	75	22	65	0375
E2 S - 40x 16	7964	40	16	42	83	32,5	75	22	68	4972
E2 S - 40x 20	7965	40	20	42	83	32,5	85	22	80	4972
E2 S - 40x 25	7966	40	25	48	83	32,5	85	22	76	4972
E2 S - 40x 32	7967	40	32	56	83	32,5	85	22	76	4972
E2 S - 40x 40	7968	40	40	65	83	32,5	97	22	90	0390
E2 S - 50x 32	7972	50	32	56	98	35	98	30	90	4972
E2 S - 50x 40	7973	50	40	65	98	35	115	30	105	0390
E2 S - 50x 50	7974	50	50	76	98	35	125	30	112	0390

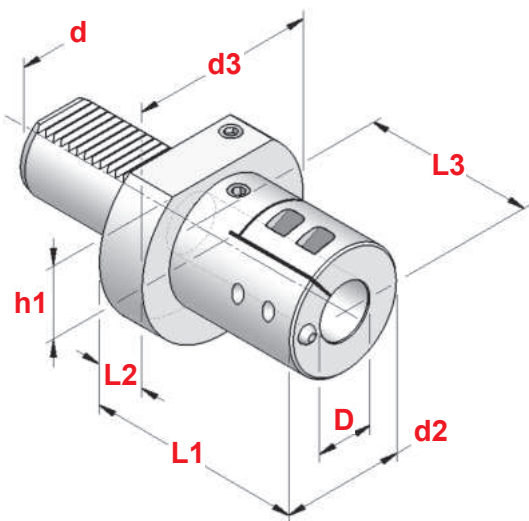

CARATTERISTICHE

- La chiusura a collare è consigliata per il bloccaggio di utensili che lavorano a sbalzo e di bareni antivibranti
- Fissaggio effettuato con viti : una direttamente sul piano dell'utensile mentre le altre ne stringono lo stelo

CHARACTERISTICS

- The collar closure is recommended for locking tools that work cantilever and anti-vibration boring bars
- Fixing carried out with screws: one directly on the tool plane while the others tighten the shank



VDI DIN 69880 / ISO 10889	PORTABARENI DOPPI DESTRI DOUBLE BORING BAR HOLDERS - RIGHT HAND
-------------------------------------	---

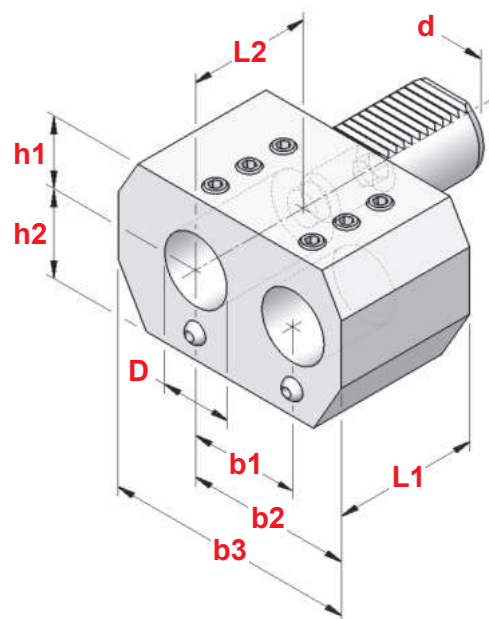

TIPO	Art.	d	D	h1	h2	L1	L2	b1	b2	b3
E7 - 30x25	7981	30	25	28	32	56	52	45	65	95
E7 - 40x32	7982	40	32	32,5	40	66	60	50	75	115
E7 - 50x50	7984	50	50	35	49	115	100	68	103	152

VDI DIN 69880 / ISO 10889	PORTABARENI DOPPI SINISTRI DOUBLE BORING BAR HOLDERS - LEFT HAND
-------------------------------------	--

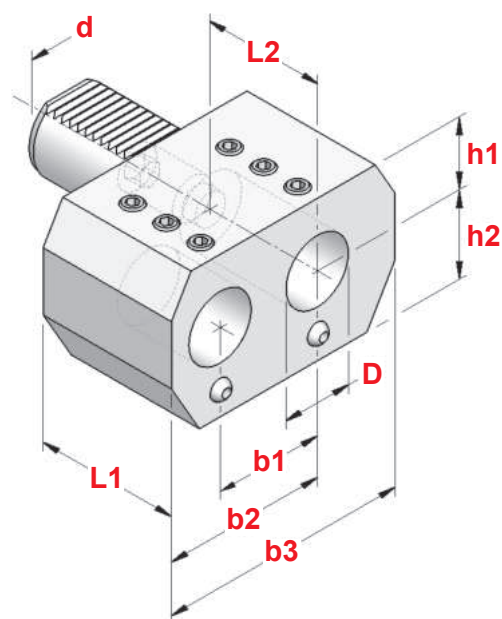

TIPO	Art.	d	D	h1	h2	L1	L2	b1	b2	b3
E8 - 30x25	7987	30	25	28	32	56	52	50	65	95
E8 - 40x32	7988	40	32	32,5	40	66	60	50	75	115
E8 - 50x50	7990	50	50	35	49	115	100	68	103	152

VDI
DIN 69880 / ISO 10889

AUTOSERRANTI CON PASSAGGIO CENTRALE DEL REFRIGERANTE
MONOLITHIC DRILL CHUCKS WITH CENTRAL COOLANT FLOW

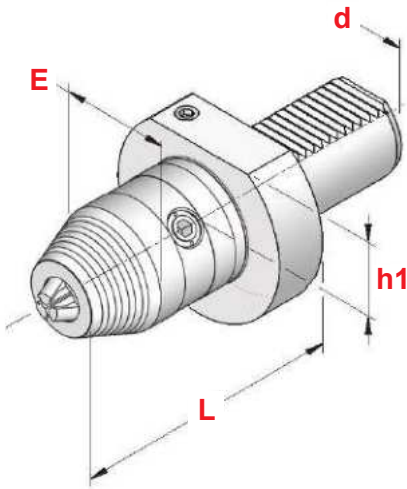

TIPO	Art.	d	E	h1	L	RANGE	
VDI 30 - DCU 13 C	9304	30	50	28	93	0,5 ÷ 13	2372
VDI 30 - DCU 16 C	9305	30	50	28	98	3 ÷ 16	
VDI 40 - DCU 13 C	9306	40	50	32,5	93	0,5 ÷ 13	2372
VDI 40 - DCU 16 C	9307	40	50	32,5	98	3 ÷ 16	

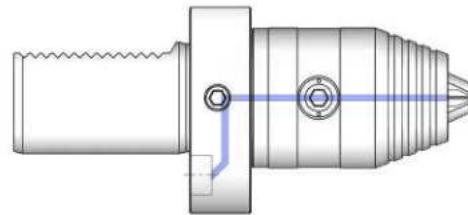

Uscita del refrigerante dalla sede utensile

Coolant exit through the tool seat



Forniti completi dell'apposita chiave
Supplied complete with suitable wrench

VDI
DIN 69880 / ISO 10889

AUTOSERRANTI CON UGELLI DI REFRIGERAZIONE
MONOLITHIC DRILL CHUCKS WITH COOLING NOZZLES

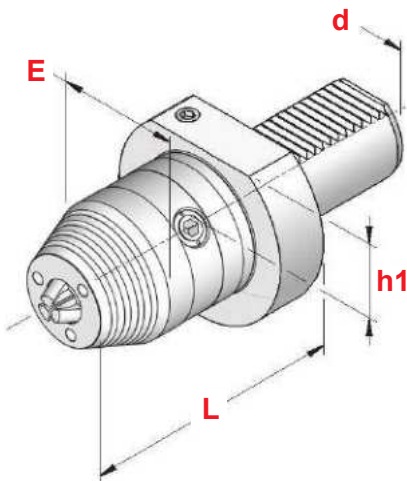

TIPO	Art.	d	E	h1	L	RANGE	
VDI 30 - DCU 13 E	9312	30	57	28	87	0,5 ÷ 13	2372
VDI 30 - DCU 16 E	9313	30	57	28	92	3 ÷ 16	
VDI 40 - DCU 13 E	9314	40	57	32,5	87	0,5 ÷ 13	2372
VDI 40 - DCU 16 E	9315	40	57	32,5	92	3 ÷ 16	

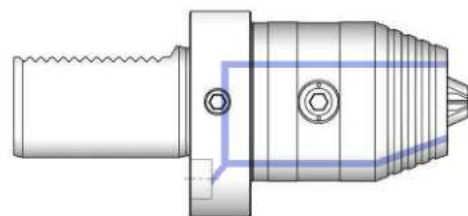

Uscita del refrigerante attraverso ugelli frontali

Coolant exit through front nozzles



Forniti completi dell'apposita chiave
Supplied complete with suitable wrench

VDI
DIN 69880 / ISO 10889

PORTAPINZA PER PINZE ER

DIN 6499 ER COLLET CHUCKS

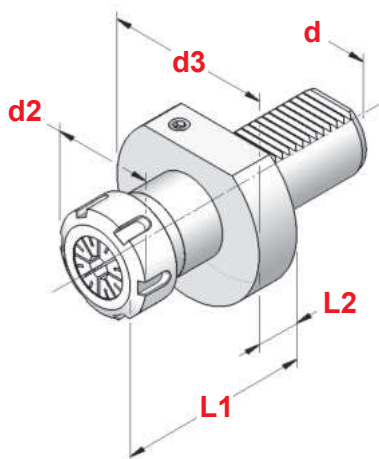

TIPO	Art.	d	d2	d3	RANGE	L1	L2			
E4 -16x16 (ER 16)	3076	16	32	40	ER16 1÷12	38	13	4993	3698	0364
E4 -16x20 (ER 20)	3078	16	35	40	ER20 1÷15	44	13	4994	3699	0787
E4 -20x16 (ER 16)	3547	20	32	50	ER16 1÷12	44	18	4993	3698	0364
E4 -20x20 (ER 20)	3303	20	35	50	ER20 1÷15	44	18	4994	3699	0787
E4 -20x25 (ER 25)	3304	20	42	50	ER25 1÷20	50	18	4995	3669	0996
E4 -20x32 (ER 32)	3549	20	50	50	ER32 2÷25	62	18	4996	3670	0988
E4 -30x16 (ER 16)	3550	30	32	68	ER16 1÷12	48	22	4993	3698	0364
E4 -30x20 (ER 20)	3551	30	35	68	ER20 1÷15	59	22	4994	3699	0787
E4 -30x25 (ER 25)	3305	30	42	68	ER25 1÷20	57	22	4995	3669	0996
E4 -30x32 (ER 32)	3306	30	50	68	ER32 2÷25	62	22	4996	3670	0988
E4 -30x40 (ER 40)	3307	30	63	68	ER40 3÷32	70	22	4997	3671	0821
E4 -40x20 (ER 20)	3553	40	35	83	ER20 1÷15	59	22	4994	3699	0787
E4 -40x25 (ER 25)	3554	40	42	83	ER25 1÷20	62	22	4995	3669	0996
E4 -40x32 (ER 32)	3308	40	50	83	ER32 2÷25	62	22	4996	3670	0988
E4 -40x40 (ER 40)	3309	40	63	83	ER40 3÷32	75	22	4997	3671	0821
E4 -50x25 (ER 25)	2304	50	42	98	ER25 1÷20	67	30	4995	3669	0996
E4 -50x32 (ER 32)	2320	50	50	98	ER32 2÷25	75	30	4996	3670	0988
E4 -50x40 (ER 40)	3311	50	63	98	ER40 3÷32	75	30	4997	3671	0821
E4 -60x32 (ER 32)	9387	60	50	123	ER32 2÷25	78	30	4996	3670	0988
E4 -60x40 (ER 40)	9388	60	63	123	ER40 3÷32	75	30	4997	3671	0821

DIN ISO 10889-6 E4



VDI
DIN 69880 / ISO 10889

PORTAPINZA PER PINZE EOC

DIN 6388 EOC COLLET CHUCKS

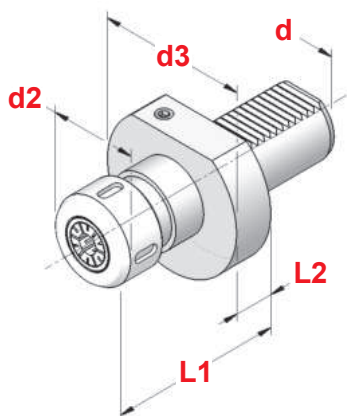

TIPO	Art.	d	d2	RANGE	L1	L2			
E3-40x25 (EOC 25)	5645	40	60	EOC25 2÷25	75	22	4068	2909	0769
E3-40x32 (EOC 32)	5646	40	72	EOC32 3÷32	90	22	4069	2910	0770

DIN ISO 10889-6 E3



VDI
DIN 69880 / ISO 10889

PORTAUTENSILI CON SEDE CONO MORSE
MORSE TAPER TOOLHOLDERS

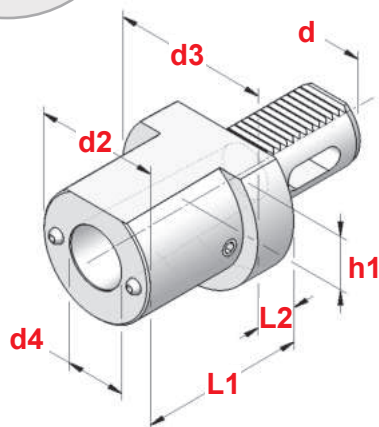

DIN ISO 10889-7 F

TIPO	Art.	d	CM	d2	d3	d4	h1	L1	L2
F30-MK-D1	5630	30	1	68	68	12,065	28	27	-
F30-MK-D2	5625	30	2	68	68	17,780	28	27	-
F30-MK-D3	5818	30	3	68	68	23,825	28	73	-
F40-MK-D1	5723	40	1	55	83	12,065	32,5	36	22
F40-MK-D2	5777	40	2	55	83	17,780	32,5	36	22
F40-MK-D3	5778	40	3	58	83	23,825	32,5	36	22
F40-MK-D4	5779	40	4	68	83	31,267	32,5	80	22
F50-MK-D2	5819	50	2	55	98	17,780	35	36	30
F50-MK-D3	5820	50	3	58	98	23,825	35	36	30
F50-MK-D4	5821	50	4	68	98	31,267	35	50	30
F60-MK-D3	9390	60	3	58	123	23,825	42,5	36	30
F60-MK-D4	9391	60	4	68	123	31,267	42,5	50	30
F60-MK-D5	9392	60	5	98	123	44,399	42,5	63	30



VDI
DIN 69880 / ISO 10889

BARRE DI CONTROLLO
TEST ARBORS



TIPO	Art.	d	D	H
VDI 30	7896	30	40	230
VDI 40	7897	40	50	300
VDI 50	7898	50	50	300
VDI 60	7899	60	60	300

Dati costruttivi

- Costruite in acciaio da cementazione certificato
- Cementate con profondità 0,6 - 0,8 mm
- Temprate, rinvenute, brunite
- Durezza HRC 58 ± 2, resistenza 800-1000 N/mm²
- Rotondità in rotazione 0,005
- Cilindricità 0,003

Constructive Features

- Manufactured with hardening steel
- Hardened 0,6 - 0,8 mm depth
- Hardened, tempered, burnished
- Hardness HRC 58 ± 2, strenght 800-1000 N/mm²
- Runout accuracy 0,005
- Cylindricity 0,003



Fornite con apposito contenitore
Supplied with suitable case

VDI
DIN 69880 / ISO 10889

STRINGIBARRA CON ATTACCO VDI
VDI SHANK BAR PULLERS

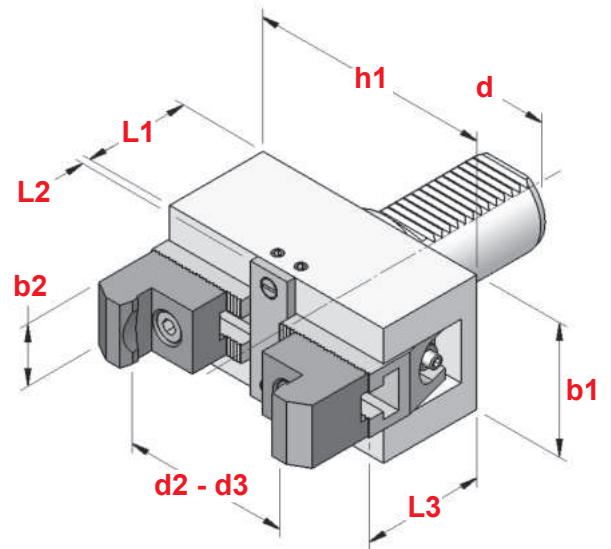

TIPO	Art.	d	d2	d3	b1	b2	h1	L1	L2	L3
H1-VDI 20	5679	20	6 ÷ 56	–	50	28	72	46	4	51
H1-VDI 30	5680	30	6 ÷ 56	54 ÷ 110	50	28	72	46	4	51
H1-VDI 40	5681	40	6 ÷ 66	54 ÷ 110	60	28	110	48	4	53

La confezione dello Stringibarra comprende le griffe per poter stringere l'intera gamma delle misure (d2-d3).

Bar Puller wrapping includes jaws to clamp the complete range of dimensions (d2-d3).

DIN 1835 A

STRINGIBARRA CON ATTACCO CILINDRICO
STRAIGHT SHANK BAR PULLERS

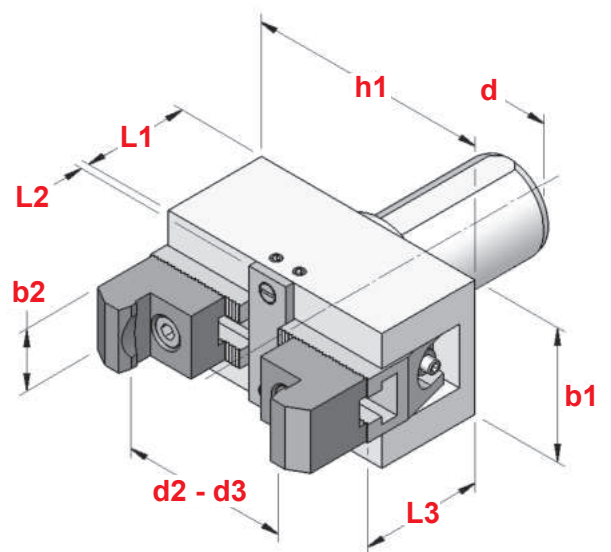

TIPO	Art.	d	d2	d3	b1	b2	h1	L1	L2	L3
H1-CIL 25	5422	25	6 ÷ 56	54 ÷ 110	50	28	72	46	4	51
H1-CIL 32	5423	32	6 ÷ 56	54 ÷ 110	50	28	72	46	4	51
H1-CIL 40	5424	40	6 ÷ 66	54 ÷ 110	60	28	110	48	4	53
H1-CIL 50	5425	50	10 ÷ 75	62 ÷ 125	65	28	130	67	5	73

La confezione dello Stringibarra comprende le griffe per poter stringere l'intera gamma delle misure (d2-d3).

Bar Puller wrapping includes jaws to clamp the complete range of dimensions (d2-d3).

VDI
DIN 69880 / ISO 10889

PORTAUTENSILI REGOLABILI CON SEDE PER LAMA DA TAGLIO - DESTRI
ADJUSTABLE HEIGHT CUT OFF TOOLHOLDERS - RIGHT HAND

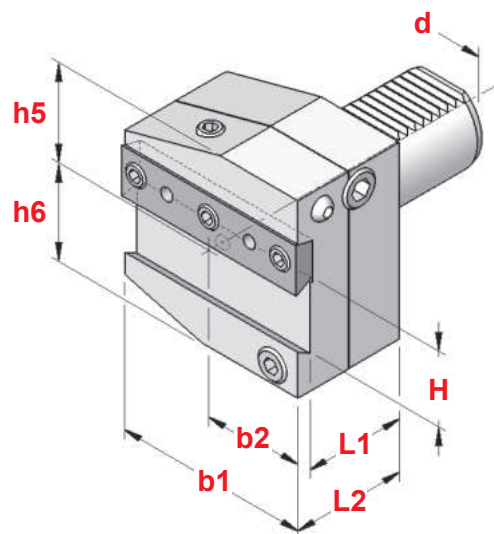

TIPO	Art.	d	b1	b2	H	h5	h6	L1	L2
AR - 30x26	7918	30	70	35	26	32	39	44	50
AR - 40x26	7919	40	85	42,5	26	43	41,5	44	50
AR - 40x32	7920	40	85	42,5	32	43	41,5	44	50
AR - 50x32	7922	50	100	50	32	43	45	44	50

VDI
DIN 69880 / ISO 10889

PORTAUTENSILI REGOLABILI CON SEDE PER LAMA DA TAGLIO - SINISTRI
ADJUSTABLE HEIGHT CUT OFF TOOLHOLDERS - LEFT HAND

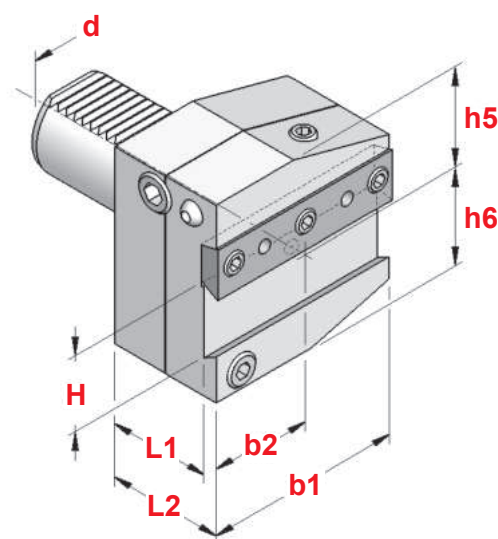
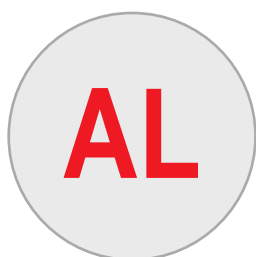

TIPO	Art.	d	b1	b2	H	h5	h6	L1	L2
AL - 30x26	7925	30	70	35	26	32	39	44	50
AL - 40x32	7927	40	85	42,5	32	43	41,5	44	50

VDI
DIN 69880 / ISO 10889

**PORTAUTENSILI REGOLABILI CON SEDE PER LAMA DA TAGLIO
ROVESCIA TI DESTRI**

UPSIDE-DOWN ADJUSTABLE HEIGHT CUT OFF TOOLHOLDERS - RIGHT HAND

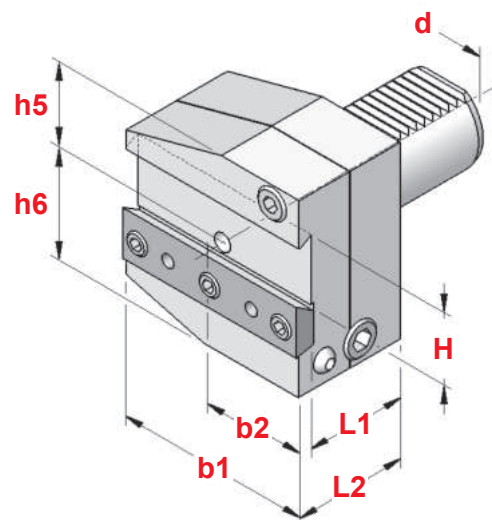

TIPO	Art.	d	b1	b2	H	h5	h6	L1	L2
ARU - 30x26	7931	30	70	35	26	38	35	44	50
ARU - 40x32	7933	40	85	42,5	32	43	41,5	44	50

VDI
DIN 69880 / ISO 10889

**PORTAUTENSILI REGOLABILI CON SEDE PER LAMA DA TAGLIO
ROVESCIA TI SINISTRI**

UPSIDE-DOWN ADJUSTABLE HEIGHT CUT OFF TOOLHOLDERS- LEFT HAND

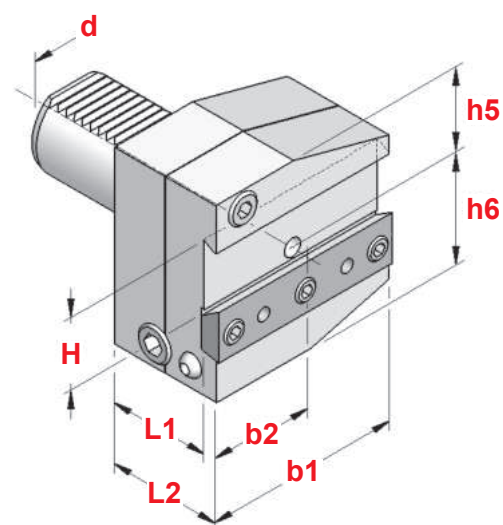

TIPO	Art.	d	b1	b2	H	h5	h6	L1	L2
ALU - 40x32	7939	40	85	42,5	32	43	41,5	44	50

VDI
DIN 69880 / ISO 10889

BROCCIATORI
BROACH TOOLHOLDERS

TIPO	Art.	d	D	P	d2	d3	L
VDI 20 - G 12	9319	20	12	25	44	50	57
VDI 30 - G 12	9320	30	12	25	58	68	83
VDI 30 - G 16	9321	30	16	40	58	68	83
VDI 40 - G 12	9322	40	12	25	58	83	83
VDI 40 - G 16	9323	40	16	40	58	83	83

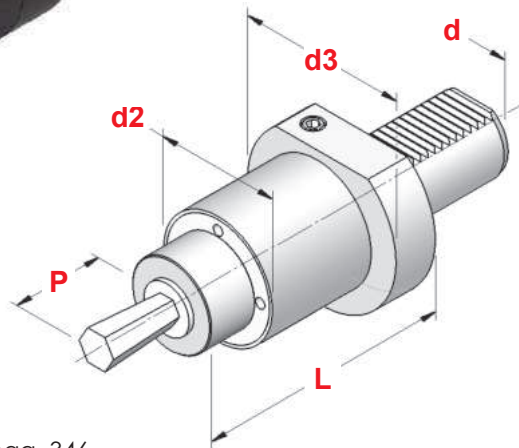

Per il corretto funzionamento del brocciatore è importante rispettare la quota **P** della broccia

For the right broaching toolholder working is important to respect broach **P** dimension

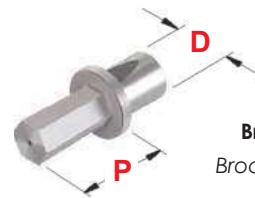



Brocche da pag. 348
Broaches from page 348





Informazioni da pag. 346
Informations from page 346

VDI
DIN 69880 / ISO 10889

PORTA ALESATORI FLOTTANTI CON PINZE ER
FLOATING REAMER HOLDERS WITH ER COLLETS

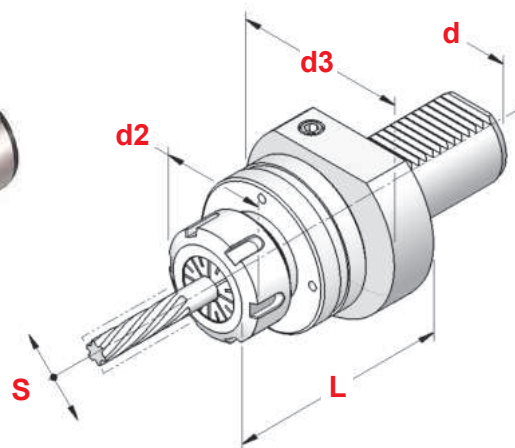
TIPO	Art.	d	d2	d3	S	L	RANGE			
VDI 20 RM - ER 25	9300	20	42	57	1	57	ER 25 1÷20	4995	3669	0996
VDI 30 RM - ER 32	9301	30	50	68	1,5	72	ER 32 2÷25	4996	3670	0988
VDI 40 RM - ER 32	9302	40	50	83	1,5	74	ER 32 2÷25	4996	3670	0988



 Passaggio centrale del refrigerante
Central coolant flow

S = scostamento radiale.
Il movimento radiale consente l'allineamento dell'asse dell'utensile

S = radial shift.
Radial movement allows the tool axis alignment



VDI
DIN 69880 / ISO 10889

**MASCHIATORI A CAMBIO RAPIDO CON
DOPPIA COMPENSAZIONE**
DOUBLE COMPENSATION QUICK CHANGE TAPPING CHUCKS

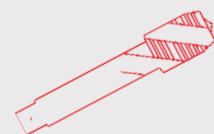

TIPO	Art.	d	L	D	D1	COMPENSAZIONE	
VDI 20 - B.1	5760	20	55	38	19	- 9 + 9	M 3 ÷ M 12 (*M18)
VDI 30 - B.1	5780	30	55	38	19	- 9 + 9	M 3 ÷ M 12 (*M18)
VDI 30 - B.2	5781	30	77	55	31	-15 + 15	M 6 ÷ M 20 (*M30)
VDI 40 - B.1	5782	40	55	38	19	- 9 + 9	M 3 ÷ M 12 (*M18)
VDI 40 - B.2	5783	40	77	55	31	-15 + 15	M 6 ÷ M 20 (*M30)
VDI 40 - B.3	5784	40	120	79	48	-24 + 24	M14 ÷ M 33 (*M48)
VDI 50 - B.2	5793	50	77	55	31	-15 + 15	M 6 ÷ M 20 (*M30)
VDI 50 - B.3	5794	50	108	79	48	-24 + 24	M14 ÷ M 33 (*M48)

* Bussole con GRANI
Adapters with SCREWS

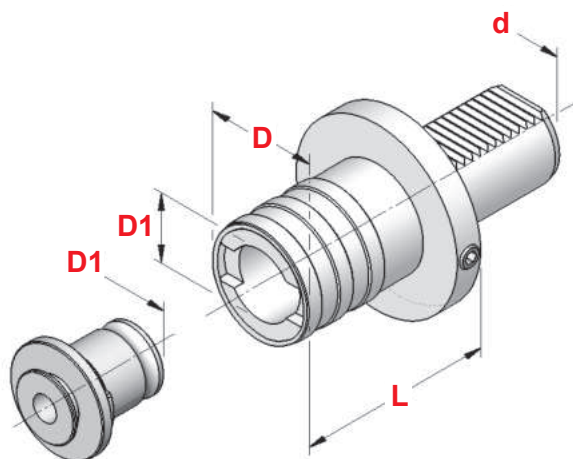

Bussole SENZA FRIZIONE
Adapters without clutch



Bussole CON FRIZIONE
Adapters with clutch



Bussole PORTAPINZA ER
Adapters ER collet holders



Bussole PORTA FILIERA
Adapters Threading Die holders

VDI
DIN 69880 / ISO 10889

TAMPONI DI PROTEZIONE IN PLASTICA O IN ACCIAIO
PLASTIC OR STEEL BLANKING PLUGS

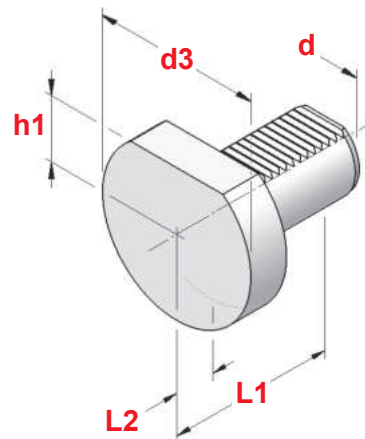

DIN ISO 10889-8 Z2

IN PLASTICA PLASTIC TYPE		IN ACCIAIO STEEL TYPE		d	d3	h1	L1	L2
TIPO	Art.	TIPO	Art.					
Z2 - 16	7991	Z2 - 16 S	7993	16	40	18	45	13
Z2 - 20	5826	Z2 - 20 S	7994	20	50	23	56	16
Z2 - 30	5827	Z2 - 30 S	7995	30	68	28	71	16
Z2 - 40	5828	Z2 - 40 S	7996	40	83	32,5	83	20
Z2 - 50	5829	Z2 - 50 S	7997	50	98	35	98	20
Z2 - 60	7992	Z2 - 60 S	7998	60	123	42,5	114	20

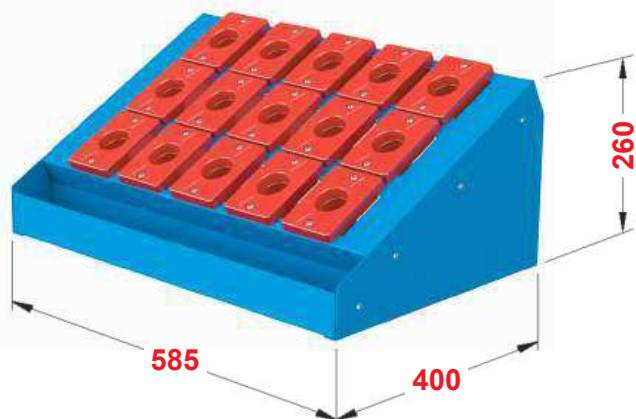

Forniti completi di boccole
Supplied complete of
tool holder bushings

MAGAZZINI PORTAUTENSILI VDI
VDI TOOLHOLDERS STORES



TIPO	Art.	N° SEDI	
MAGAZZINO VDI 30 - Ø 32	3705	15	5531
MAGAZZINO VDI 40 - Ø 40	3706	15	5532
MAGAZZINO VDI 50 - Ø 50	5557	12	5533



Fornite complete di boccole
Supplied complete of
tool holder bushings

UNITA' DA BANCO VDI
VDI BENCH UNITIES



TIPO	Art.	N° SEDI	
UNITA' VDI 30 - Ø 32	5369	5	5531
UNITA' VDI 40 - Ø 40	5370	5	5532
UNITA' VDI 50 - Ø 50	5371	4	5533

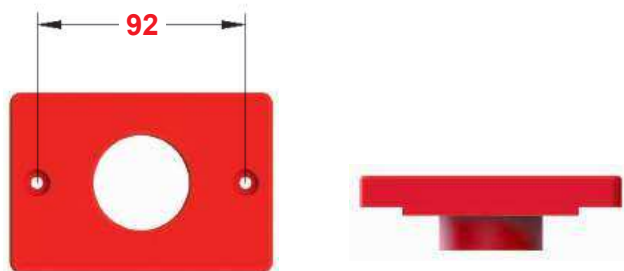

BOCCOLE VDI
VDI PLASTIC BUSHES



TIPO	Art.	
BOCCOLA VDI 30 - Ø 32	5531	0033
BOCCOLA VDI 40 - Ø 40	5532	0033
BOCCOLA VDI 50 - Ø 50	5533	0033

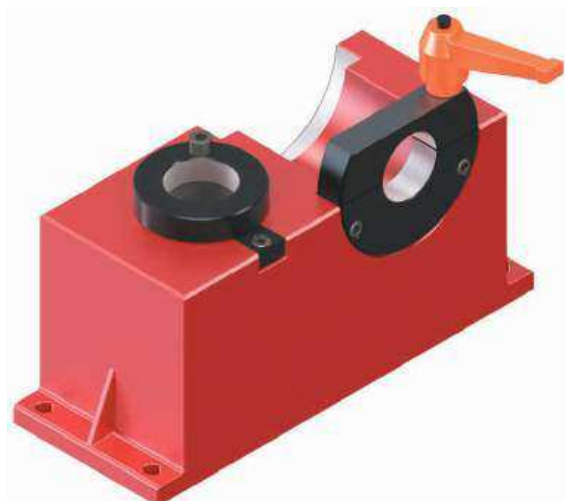

SUPPORTI DI MONTAGGIO VDI
VDI TIGHTENING FIXTURES

TIPO	Art.	L x P x H
SMD - VDI 30/DIN 69880	4615	350 x 135 x 155
SMD - VDI 40/DIN 69880	4616	
SMD - VDI 50/DIN 69880	4617	

UGELLI A SFERA
SPHERE COOLANT NOZZLES

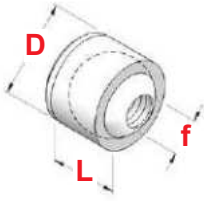

Art.	D	L	f
9200	6	5	M 2,5
9201	8	6	M 4
9202	10	7	M 5
9203	12	8	M 5
9204	12	8	M 6
9205	14	9	M 8
9206	16	10	M 10x1



PROLUNGHE PER UGELLI
EXTENSIONS FOR COOLANT NOZZLES

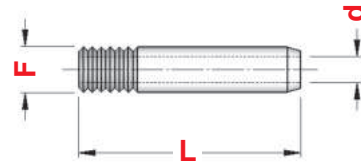

Art.	F	d	L
9210	M 3	1,5	25
9211	M 4	1	30
9212	M 4	2	30
9213	M 5	2	30
9214	M 5	3	40
9215	M 6	2	35
9216	M 6	3	35
9217	M 6	4	50
9218	M 8	2	40
9219	M 8	3	40
9220	M 8	4	40
9221	M 8	5	50
9222	M10x1	2	40
9223	M10x1	4	40
9224	M10x1	6	50
9225	M10x1	8	50

UGELLI A SFERA PER ALTA PRESSIONE
SPHERE COOLANT NOZZLES FOR HIGH PRESSURE

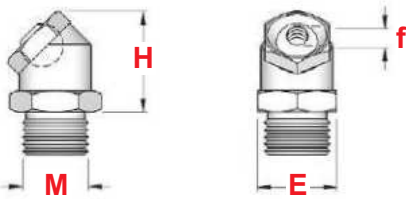

Art.	f	E	M	H
9235	M 3	16	1/8	19
9236	M 5	18	1/4	21
9237	M 6	20	3/8	23
9238	M 8	23	3/8	27



UGELLI PER ALTA PRESSIONE ORIENTABILI
ORIENTABLE COOLANT NOZZLES FOR HIGH PRESSURE

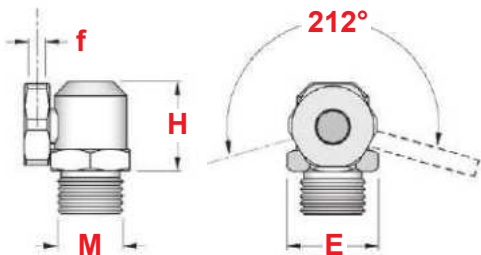

Art.	f	E	M	H
9240	M 4	12	1/8	17
9241	M 5	14	1/8	18
9242	M 6	17	1/4	21



PROLUNGHE PER UGELLI A 45°
45° EXTENSIONS FOR COOLANT NOZZLES

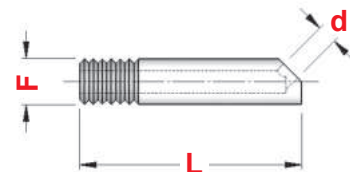

Art.	F	d	L
9230	M 5	2,5	23
9231	M 6	3	30
9232	M 8	4	35

PORTABARENI A MONTAGGIO LONGITUDINALE PER TORRETTE
 LONGITUDINAL MOUNTING BORING BAR HOLDERS FOR TURRETS

PU1

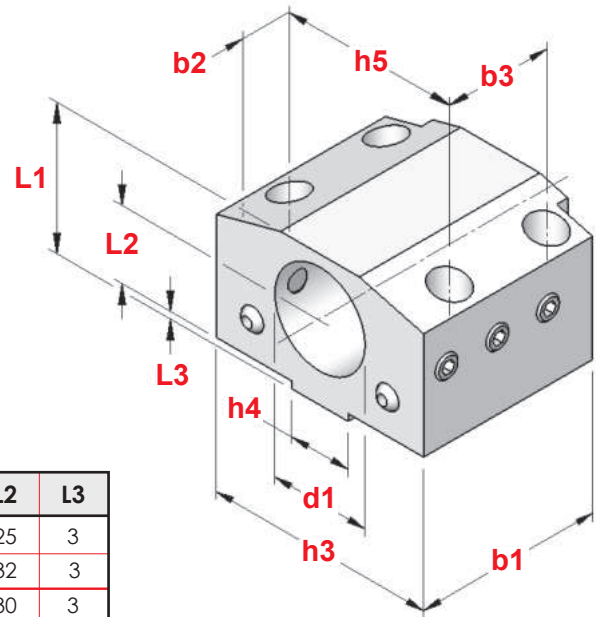

TIPO	Art.	d1	h3	h4	h5	b1	b2	b3	L1	L2	L3
PU1 20-32	7902	32	74	20	57	60	17,5	34	48	25	3
PU1 20-40	7903	40	74	20	57	60	17,5	34	60	32	3
PU1 25-20	7904	20	92	25	71	75	22	43	58	30	3
PU1 25-25	7905	25	92	25	71	75	22	43	58	30	3
PU1 25-32	7906	32	92	25	71	75	22	43	58	30	3
PU1 25-40	7907	40	92	25	71	75	22	43	58	30	3
PU1 25-50	7908	50	92	25	71	75	22	43	73	38	3
PU1 32-25	7909	25	115	32	90	95	26	57	73	35	3
PU1 32-32	7910	32	115	32	90	95	26	57	73	35	3
PU1 32-40	7911	40	115	32	90	95	26	57	73	35	3
PU1 32-50	7912	50	115	32	90	95	26	57	73	35	3
PU1 32-60	7913	60	115	32	90	95	26	57	83	40	3

PORTAUTENSILI QUADRI A MONTAGGIO LONGITUDINALE PER TORRETTE
 LONGITUDINAL MOUNTING SQUARE TOOL HOLDERS FOR TURRETS

PU2

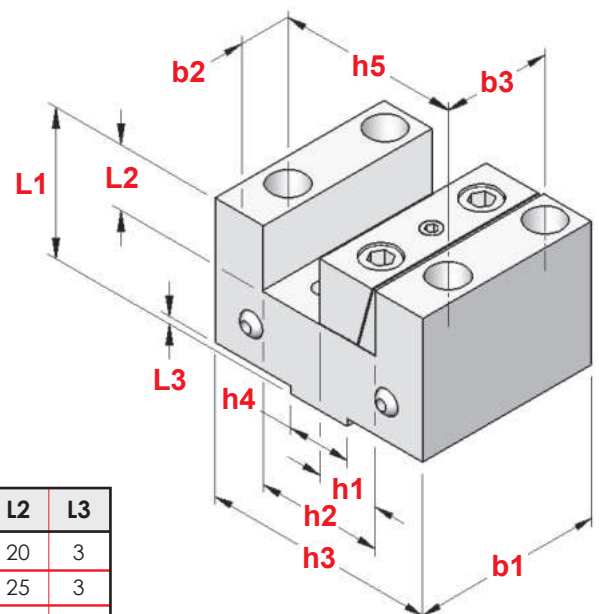

TIPO	Art.	h1	h2	h3	h4	h5	b1	b2	b3	L1	L2	L3
PU2 20-20	7914	20	40	74	20	57	60	17,5	34	43	20	3
PU2 25-25	7915	25	50	92	25	71	75	22	43	53	25	3
PU2 32-32	7916	32	64	115	32	90	95	26	57	63	32	3



PORTABARENI PER TORNI BIGLIA B 1000

BORING BAR HOLDERS FOR BIGLIA B 1000 LATHES

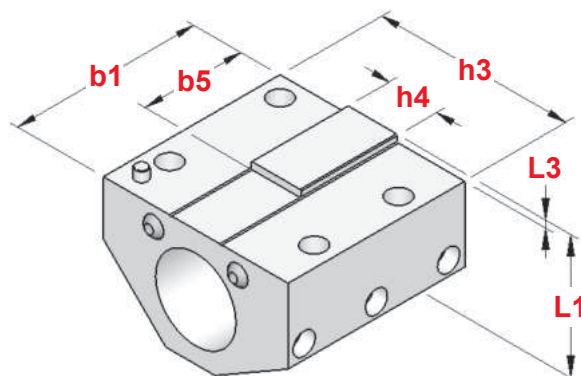
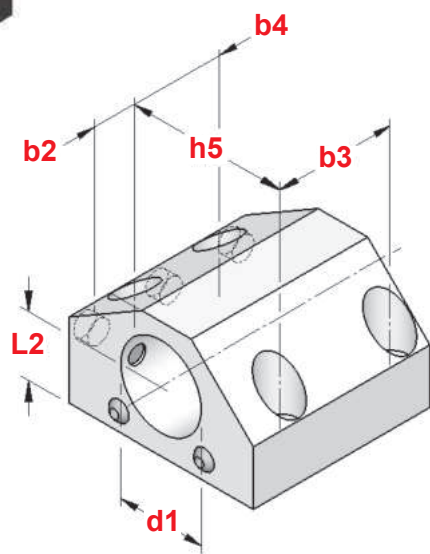

TIPO	Art.	d1	h3	h4	h5	b1	b2	b3	b4	b5	L1	L2	L3
BIGLIA 10.57.20.01	5799	32	92	25	72	88	23	55	42	48	61,5	30	3,5
BIGLIA 10.57.20.02	5800	40	92	25	72	88	23	55	42	48	61,5	30	3,5



PORTABARENI PER TORNI BIGLIA B 56 e B 500

BORING BAR HOLDERS FOR BIGLIA B 56 AND B 500 LATHES

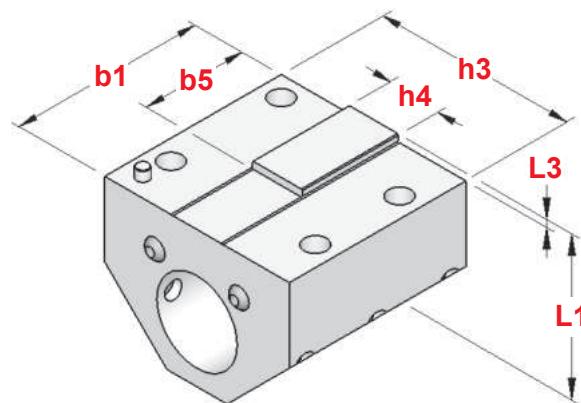
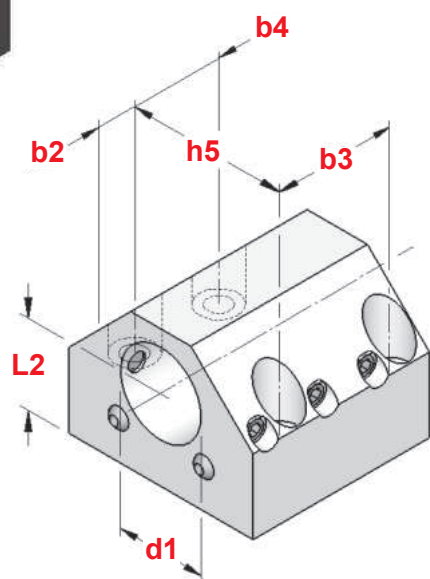

TIPO	Art.	d1	h3	h4	h5	b1	b2	b3	b4	b5	L1	L2	L3
BIGLIA 10.57.20.14	5830	32	92	25	72	88	23	55	42	48	71,5	40	3,5
BIGLIA 10.57.20.16	5831	40	92	25	72	88	23	55	42	48	71,5	40	3,5

FERMOBARRA ROTANTI REGOLABILI
 STRAIGHT SHANK ROTARY ADJUSTABLE BAR-STOP

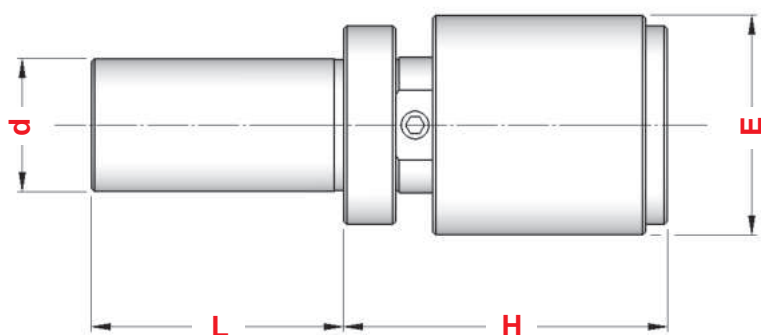

Art.	d	L	H	E
1520	16,00	32	36 - 62	20
1719	19,05	32	36 - 62	20
1720	19,05	46	45 - 75	26
1447	20,00	50	62-100	34
1448	22,00	50	62-100	34
1449	25,00	50	62-100	34
1459	25,00	50	62-100	42
1460	25,00	50	62-100	56
1450	25,40	50	62-100	34
1730	30,00	50	62-100	42
1735	30,00	50	62-100	56
1732	32,00	50	62-100	42
1773	32,00	50	62-100	56
1736	40,00	70	62-100	42
1797	40,00	70	62-100	56

FERMOBARRA ROTANTI REGOLABILI AMMORTIZZATI
 DAMPED STRAIGHT SHANK ROTARY ADJUSTABLE BAR-STOP

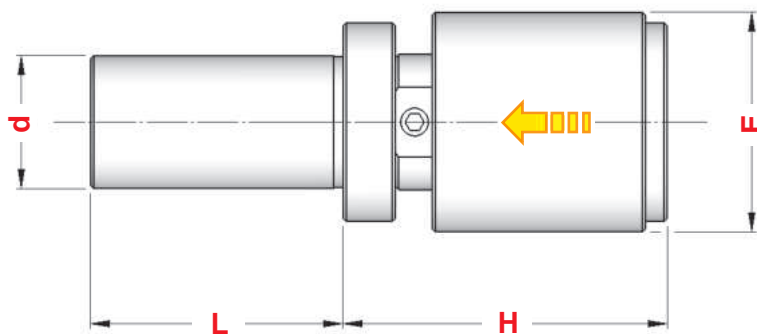

Art.	d	L	H	E
2629	20,00	35	62 - 90	34
2630	20,00	50	62 -100	34
2635	25,00	50	62 -100	34
2421	25,00	50	62 -100	42
2447	25,00	50	62 -100	56
0985	25,40	50	62 -100	34
1024	25,40	50	62 -100	42
1062	25,40	50	62 -100	56
1537	30,00	50	62 -100	42
1552	30,00	50	62 -100	56
1560	31,75	50	62 -100	42
1565	31,75	50	62 -100	56
1025	32,00	50	62 -100	42
1063	32,00	50	62 -100	56
1061	40,00	70	62 -100	42
1073	40,00	70	62 -100	56

CARATTERISTICHE : a differenza del normale fermobarra rotante, nel modello ammortizzato, oltre al cuscinetto radiale ed al reggispinta, è presente una serie di molle a tazza per meglio assorbire eventuali urti della barra.



CHARACTERISTICS: unlike normal rotary bar stop, inside damped model, besides radial bearing and thrust bearing, there is a set of spring washers in order to absorb well any bar shoves.

**DIN
1835 A**

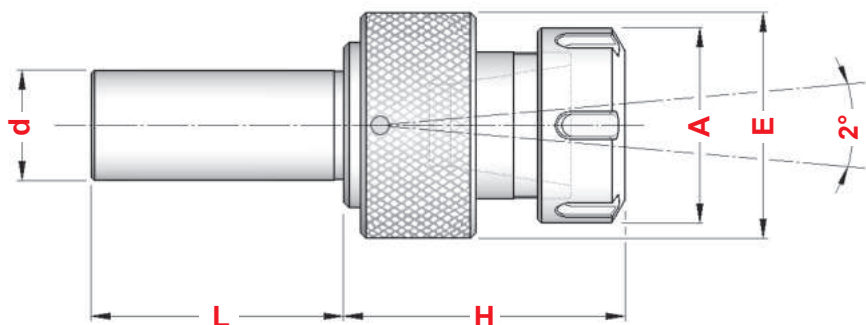

PORTA ALESATORI OSCILLANTI CON PINZA ER
STRAIGHT SHANK FLOATING REAMER HOLDERS WITH ER COLLET

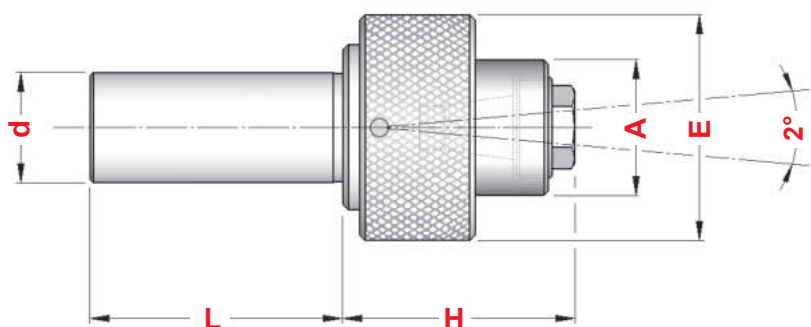

p.10

TIPO	Art.	d	A	E	H	L	RANGE			
d 16 RM - ER 16	1152	16	32	40	50	46	ER 16 1÷12	4993	3698	0364
d 16 RM - ER 20	1173	16	35	40	55	46	ER 20 1÷15	4994	3699	0787
d 19,05 RM - ER 16	1176	19,05	32	40	50	46	ER 16 1÷12	4993	3698	0364
d 19,05 RM - ER 20	1340	19,05	35	40	55	46	ER 20 1÷15	4994	3699	0787
d 20 RM - ER 16	1227	20	32	40	50	46	ER 16 1÷12	4993	3698	0364
d 20 RM - ER 20	1573	20	35	40	55	46	ER 20 1÷15	4994	3699	0787
d 20 RM - ER 25	1237	20	42	61	58	46	ER 25 1÷20	4995	3669	0996
d 25 RM - ER 20	1241	25	35	40	55	46	ER 20 1÷15	4994	3699	0787
d 25 RM - ER 25	1242	25	42	61	58	46	ER 25 1÷20	4995	3669	0996
d 25 RM - ER 32	1341	25	50	61	70	46	ER 32 2÷25	4996	3670	0988
d 25,4 RM - ER 32	1342	25,4	50	61	70	46	ER 32 2÷25	4996	3670	0988
d 32 RM - ER 32	1895	32	50	61	70	50	ER 32 2÷25	4996	3670	0988



TIPO	Art.	d	A	E	H	L	RANGE			
d 16 RM - ER 11	1141	16	24	40	42	46	ER 11 1÷8	2601	3169	5573
d 20 RM - ER 11	1213	20	24	40	42	46	ER 11 1÷8	2601	3169	5573

ME

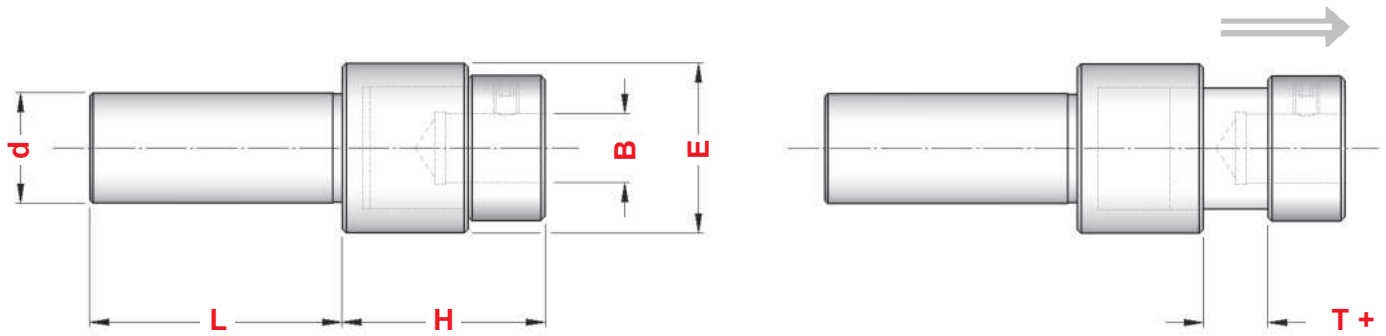

PORTA MASCHI AD ESTRAZIONE
STRAIGHT SHANK DRAW-OUT TAPPING CHUCKS



TIPO	Art.	d	L	H	E	T+	B
d 16 ME	1658	16,00	32	29	29	+ 8	10
d 19,05 ME	1451	19,05	50	38	34	+ 12	12
d 20 ME	1452	20,00	50	38	34	+ 12	12
d 25 ME	1725	25,00	50	49	42	+ 16	18
d 25,4 ME	1453	25,40	50	49	42	+ 16	18

MEP

PORTA MASCHI AD ESTRAZIONE CON PINZA ER
STRAIGHT SHANK DRAW-OUT TAPPING CHUCKS WITH ER COLLET

TIPO	Art.	d	L	H	T+	A	RANGE			
d 16 MEP - ER 20	3152	16,00	32	63	+ 11	35	ER20 1÷15	4994	3699	0787
d 19,05 MEP - ER 20	3163	19,05	50	63	+ 11	35	ER20 1÷15	4994	3699	0787
d 20 MEP - ER 20	3164	20,00	50	63	+ 11	35	ER20 1÷15	4994	3699	0787
d 25 MEP - ER 25	3552	25,00	50	61	+ 15	42	ER25 1÷20	4995	3669	0996
d 25 MEP - ER 32	3165	25,00	50	65	+ 15	50	ER32 2÷25	4996	3670	0988
d 25,4 MEP - ER 25	3166	25,40	50	61	+ 15	42	ER25 1÷20	4995	3669	0996
d 25,4 MEP - ER 32	3555	25,40	50	65	+ 15	50	ER32 2÷25	4996	3670	0988
d 32 MEP - ER 32	3559	32,00	50	65	+ 16	50	ER32 2÷25	4996	3670	0988
d 40 MEP - ER 32	3560	40,00	70	65	+ 16	50	ER32 2÷25	4996	3670	0988

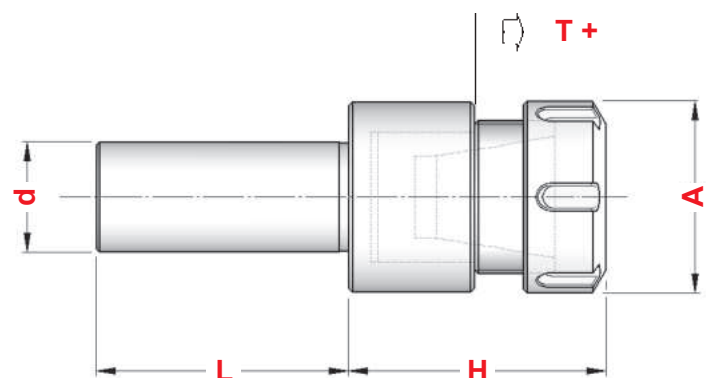

MCP

PORTA MASCHI A DOPPIA COMPENSAZIONE CON PINZA ER

DOUBLE COMPENSATION TAPPING CHUCKS WITH ER COLLET



TIPO	Art.	d	L	H	COMPENSAZIONE	A	RANGE			
d 16 MCP - ER 20	3561	16,00	32	67	- 4 + 7	35	ER20 1÷15	4994	3699	0787
d 19,05 MCP - ER 20	3562	19,05	50	67	- 4 + 7	35	ER20 1÷15	4994	3699	0787
d 20 MCP - ER 20	3563	20,00	50	67	- 4 + 7	35	ER20 1÷15	4994	3699	0787
d 25 MCP - ER 25	3572	25,00	50	67	- 6 + 9	42	ER25 1÷20	4995	3669	0996
d 25 MCP - ER 32	3573	25,00	50	71	- 6 + 9	50	ER32 2÷25	4996	3670	0988
d 25,4 MCP - ER 25	3574	25,40	50	67	- 6 + 9	42	ER25 1÷20	4995	3669	0996
d 25,4 MCP - ER 32	3575	25,40	50	71	- 6 + 9	50	ER32 2÷25	4996	3670	0988
d 32 MCP - ER 32	3578	32,00	50	71	- 6 + 10	50	ER32 2÷25	4996	3670	0988
d 40 MCP - ER 32	3579	40,00	70	71	- 6 + 10	50	ER32 2÷25	4996	3670	0988

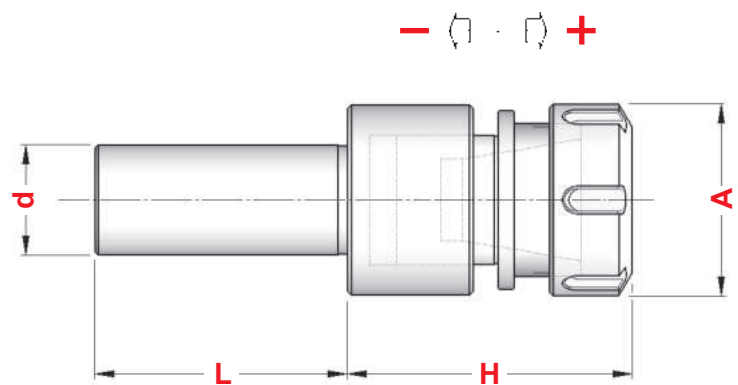

Maschiatori Doppia Compensazione a CAMBIO RAPIDO - pag. 44

Double Compensation QUICK CHANGE Tapping chucks - page 44



PFE

PORTA FILIERE AD ESTRAZIONE
 STRAIGHT SHANK DRAW-OUT THREADING DIE HOLDERS

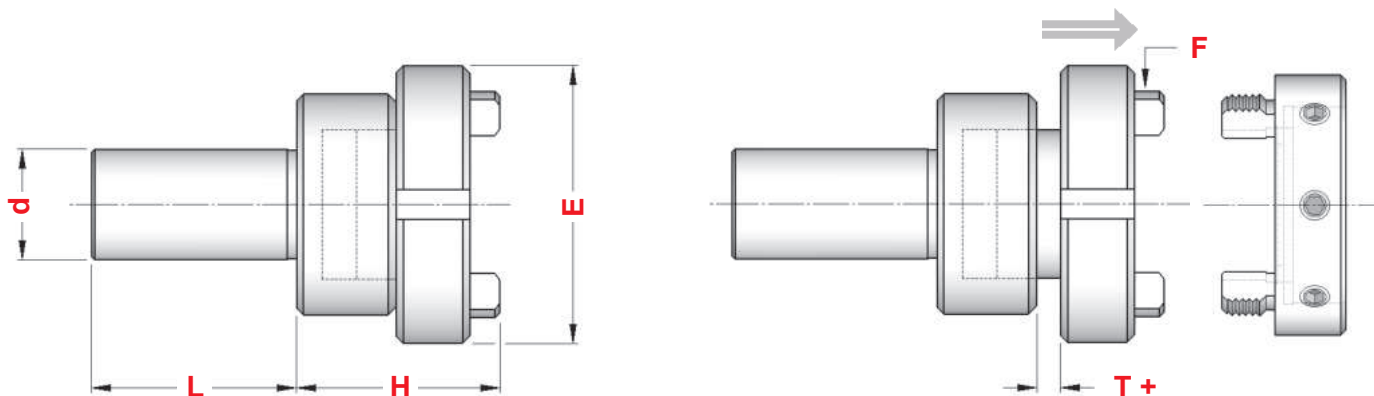

TIPO	Art.	d	L	H	E	T+	F
d 16 PFE	1637	16,00	32	33	36	+ 8	M28 x1,0
d 19,05 PFE	1814	19,05	32	42	56	+ 12	M48 x1,5
d 20 PFE	1640	20,00	32	42	56	+ 12	M48 x1,5
d 22 PFE	1641	22,00	46	42	57	+ 16	M48 x1,5
d 25 PFE	1650	25,00	50	51	70	+ 16	M60 x1,5
d 25,4 PFE	1872	25,40	46	59	70	+ 16	M60 x1,5
d 31,75 PFE	1807	31,75	50	51	70	+ 16	M60 x1,5
d 32 PFE	1916	32,00	46	59	70	+ 16	M60 x1,5
d 40 PFE	2556	40,00	85	51	70	+ 16	M60 x1,5

CAPPELLOTTI PER PORTA FILIERE AD ESTRAZIONE
 CAPS FOR DRAW OUT THREADING DIE HOLDERS

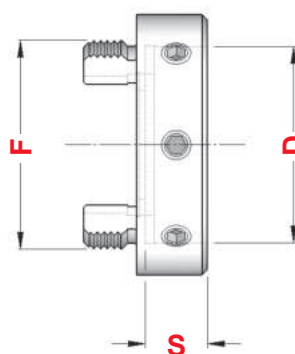

Art.	D	S	F
0054	16	5	M28 x1,0
0059	20	5	M28 x1,0
1712	20	7	M28 x1,0
0067	25	9	M28 x1,0

Art.	D	S	F
1824	20	5	M48 x1,5
1806	20	7	M48 x1,5
1803	25	9	M48 x1,5
1808	30	11	M48 x1,5
1852	38	10	M48 x1,5
1809	38	14	M48 x1,5
1810	45	14	M48 x1,5
1877	45	18	M48 x1,5
2006	50	16	M48 x1,5
2007	55	16	M48 x1,5

Art.	D	S	F
1600	25	9	M60 x1,5
1811	30	11	M60 x1,5
1804	38	10	M60 x1,5
1812	38	14	M60 x1,5
1813	45	14	M60 x1,5
1911	45	18	M60 x1,5
1805	50	16	M60 x1,5
1815	55	16	M60 x1,5
1816	65	18	M60 x1,5
1862	75	20	M60 x1,5

PORTA FILIERA FISSI
FIXED THREADING DIE HOLDERS

FISSAGGIO FRONTALE
FRONT FIXING

Art.	D	S	d	H	L	G
1093	16	5	8	40	40	34
1075	20	5	8	43	45	40
1096	20	7	8	43	45	38
1104	25	9	8	50	45	45
1106	30	11	8	50	45	47
1084	35	12	8	60	50	49

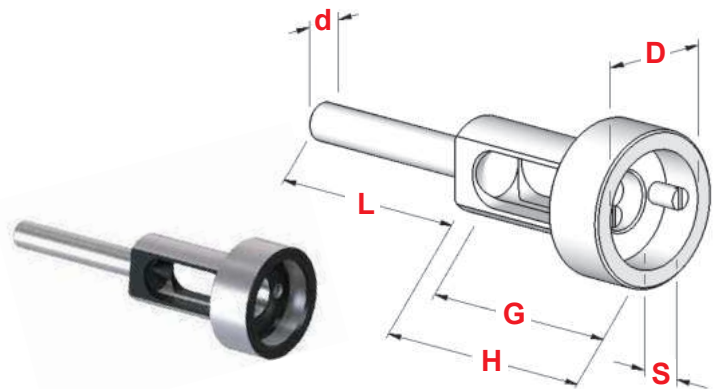

FISSAGGIO LATERALE
LATERAL FIXING

Art.	D	S	d	H	L	G
1093	16	5	8	40	40	34
1075	20	5	8	43	45	40
1095	20	7	8	43	45	38
1103	25	9	8	50	45	45
1105	30	11	8	50	45	45
1125	38	10	8	56	50	51
1107	38	14	8	56	50	52

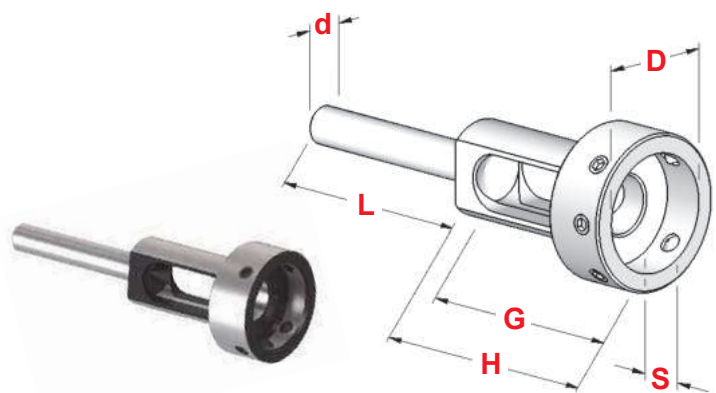

TIPO MAGGIORATO
INCREASED TYPE

Art.	D	S	d	Q	H	G
2540	20	7	9	7	60	49
2536	25	9	9	7	60	51
2537	30	11	10	8	60	51
2538	38	10	10	8	60	54
2544	38	14	12	9	60	54
2539	45	14	12	9	66	59
2558	45	18	14	11	66	59

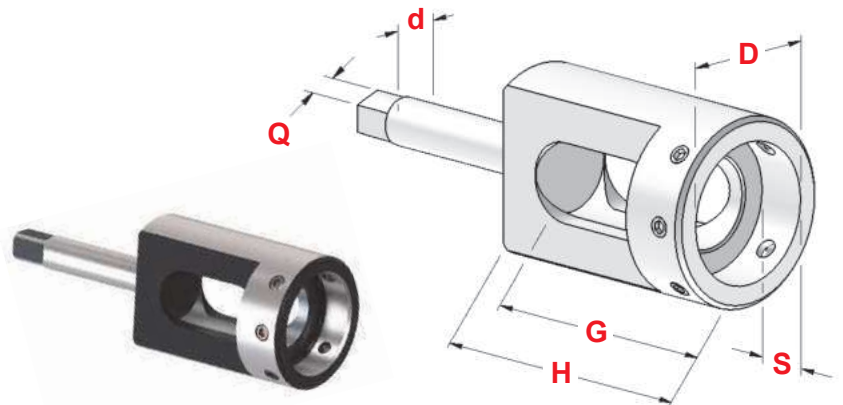

ATTACCO CONO MORSE
MORSE TAPER SHANK

Art.	D	S	CM	F	H	G
2727	16	5	2	M 10	60	51
2728	20	7	2	M 10	60	49
2729	25	9	2	M 10	60	51
2731	30	11	2	M 10	60	51
2735	38	10	2	M 10	60	54
2767	38	14	2	M 10	60	54
2776	45	14	2	M 10	66	59
2786	45	18	2	M 10	66	59

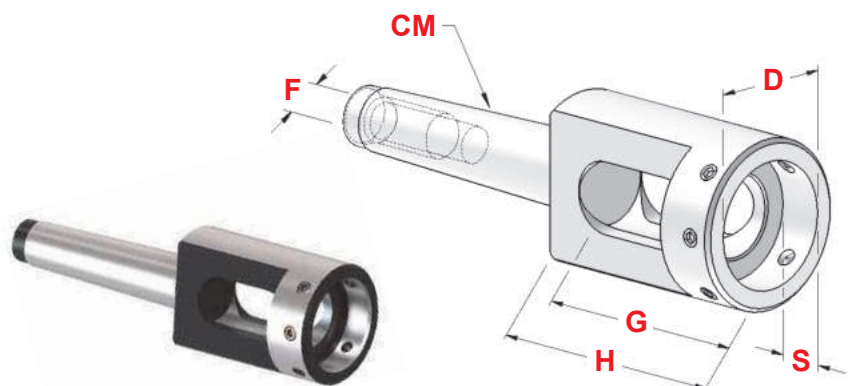

BROCCIATORI E BROCCE

BROACHING HEADS AND BROACHES

con attacco CONO MORSE
MORSE TAPER shank

pag. 66

con attacco VDI
VDI shank

pag. 334

con attacco Cilindrico
Straight shank

pag. 347

CARATTERISTICHE TECNICHE

Il funzionamento del brocciatore è dato dalla combinazione fra l'inclinazione del corpo porta broccia e la rotazione dello stesso. Questo permette di eseguire profili regolari sia in fori passanti che in fori ciechi. Con brocche specifiche si possono realizzare anche profili esterni.

L'utilizzo ottimale del brocciatore deriva dal corretto allineamento del centro della broccia con il centro del foro su cui si andrà ad effettuare la lavorazione.

Per ottenere l'allineamento dei centri, è fondamentale utilizzare brocche della lunghezza indicata in tabella.

Il brocciatore viene regolato in fabbrica, quindi l'operatore non deve effettuare alcuna messa a punto.

Si può utilizzare su torni, centri di lavoro e trapani.

Il funzionamento, nel caso venga montato sui torni, prevede la rotazione sia del pezzo da lavorare che della parte anteriore del porta utensili, mentre il corpo del brocciatore resta fermo.

Nei centri di lavoro saranno fermi sia il pezzo che la parte anteriore del porta utensili, mentre il corpo del brocciatore ruoterà.

La velocità di rotazione e l'avanzamento sono determinati dalla durezza del materiale e dalla dimensione della cava. Vedere le tabelle riassuntive a pagina 352.

TECHNICAL CHARACTERISTICS

The functioning of the broaching head is given by the combination of the inclination of the broach holder body and the rotation of the same. This allows to perform regular profiles both in through holes and in blind holes. With specific broaches it is also possible to create external profiles.

The optimal use of the broaching head derives from the correct alignment of the center of the broach with the center of the hole on which the processing will be carried out.

To obtain the alignment of the centers, it is essential to use broaches with the length indicated in the table.

The broaching head is adjusted in the factory, so the operator does not have to make any setting.

It can be used on lathes, machining centers and drills.

If it is mounted on lathes, its operation involves the rotation of both the workpiece and the front part of the tool holder, while the body of the broaching head remains stationary.

In the machining centers, both the piece and the front part of the tool holder will be stationary, while the body of the broaching head will rotate.

The rotation speed and advancement are determined by the hardness of the material and the size of the hole. See summary tables on page 352.

BROCCIATORI ATTACCO CILINDRICO
 STRAIGHT SHANK BROACHING TOOLHOLDERS

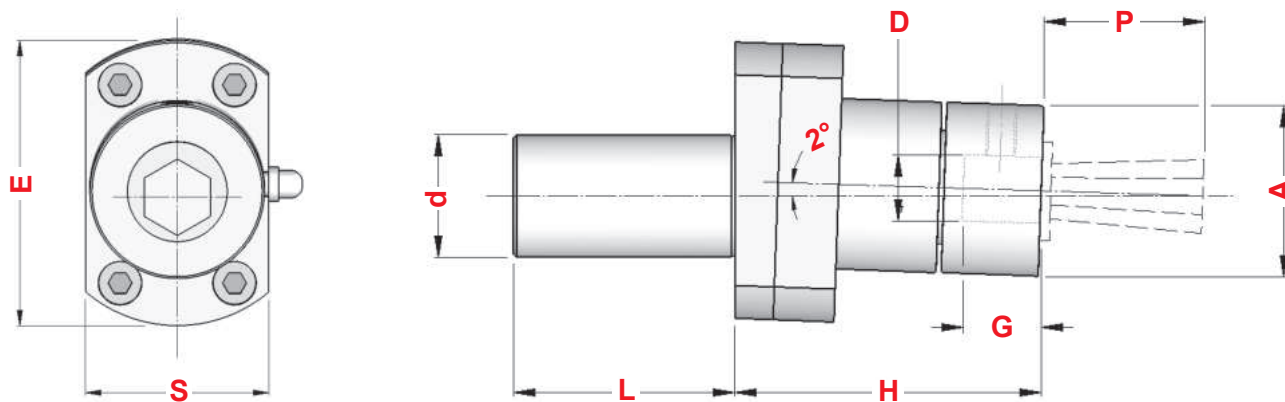

Art.	d	D	P	L	H	G	A	E	S
2312	16,00	8	18	35	42	10	22	50	30
2448	19,05	12	25	40	51	16	30	53	36
1680	20,00	12	25	40	51	16	30	53	36
1705	22,00	16	25	45	76	21	42	68	44
1707	25,00	16	25	45	76	21	42	68	44
2450	25,40	16	25	45	76	21	42	68	44
1731	30,00	16	25	45	76	21	42	68	44
2451	31,75	16	25	50	76	21	42	68	44
2709	32,00	16	25	50	76	21	42	68	44
2712	40,00	16	25	50	76	21	42	68	44



Per il corretto funzionamento del brocciatore è importante rispettare la quota P della broccia
 For the right broaching toolholder working is important to respect broach P dimension

RIDUTTORE PER SEDE BROCCIA DA GAMBO 16 A GAMBO 12
 REDUCTION FOR BROACH SEAT FROM 16 TO 12 SHANK

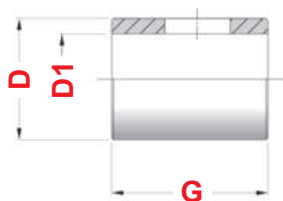
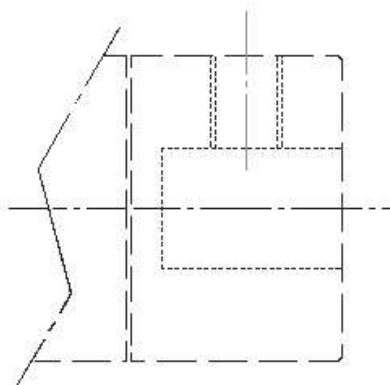

Art.	D	D1	G
2351	16	12	20,5

Attenzione: il riduttore si può utilizzare solo con brocche che hanno quota P=25

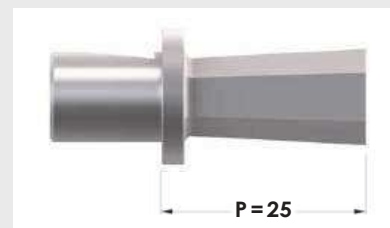

Attention: reduction can be used only with broach having P=25



BROCCE ESAGONALI
HEXAGONAL BROACHES

Broccia Esagonale

Hexagonal Broach

- HSS ⇨
- TiN ⇨
- TiAlN ⇨
- INOX-PLUS ⇨

Gambo shank
D = 5

Art.
9030

9035
9040
9045

Gambo shank
D = 8

Art.
9031

9036
9041
9046

Gambo shank
D = 12

Art.
9032

9037
9042
9047

Gambo shank
D = 16

Art.
9033

9038
9043
9048

Extended P = 40

Gambo shank
D = 16

Art.
9034

9039
—
—

E	D	G	P	H
1	5	7	10	2
1,5	5	7	10	3
2	5	7	10	4
2,5	5	7	10	5
3	5	7	10	6
3,5	5	7	10	6
4	5	7	10	7
4,5	5	7	10	7
5	5	7	10	7,5
5,5	5	7	10	7,5
6	5	7	10	7,5

E	D	G	P	H
1	8	9	18	2
1,5	8	9	18	3
2	8	9	18	5
2,5	8	9	18	6
3	8	9	18	7
3,5	8	9	18	8
4	8	9	18	9
4,5	8	9	18	9
5	8	9	18	11
5,5	8	9	18	11
6	8	9	18	13
7	8	9	18	15
8	8	9	18	15
9	8	9	18	15
10	9	9	18	15

E	D	G	P	H
1	12	15	25	2
1,5	12	15	25	3
2	12	15	25	5
2,5	12	15	25	6
3	12	15	25	7
3,5	12	15	25	8
4	12	15	25	9
4,5	12	15	25	9
5	12	15	25	11
5,5	12	15	25	11
6	12	15	25	13
7	12	15	25	15
8	12	15	25	17
9	12	15	25	19
10	12	15	25	21
11	12	15	25	21
12	12	15	25	21
13	12	15	25	21
14	12	15	25	21
15	12	15	25	21
16	12	15	25	21
17	12	15	25	21

E	D	G	P	H
1	16	19	25	2
1,5	16	19	25	3
2	16	19	25	5
2,5	16	19	25	6
3	16	19	25	7
3,5	16	19	25	8
4	16	19	25	9
4,5	16	19	25	9
5	16	19	25	11
5,5	16	19	25	11
6	16	19	25	13
7	16	19	25	15
8	16	19	25	17
9	16	19	25	19
10	16	19	25	21
11	16	19	25	21
12	16	19	25	21
13	16	19	25	21
14	16	19	25	21
15	16	19	25	21
16	16	19	25	21
17	16	19	25	21
18	16	19	25	21
19	16	19	25	21
20	16	19	25	21
22	16	19	25	21
24	16	19	25	21
25	16	19	25	21
26	16	19	25	21
27	16	19	25	21
28	16	19	25	21
29	16	19	25	21
30	16	19	25	21
31	16	19	25	21
32	16	19	25	21

E	D	G	P	H
1	16	19	40	2
1,5	16	19	40	3
2	16	19	40	3,5
2,5	16	19	40	4
3	16	19	40	5
3,5	16	19	40	6
4	16	19	40	6,5
4,5	16	19	40	7
5	16	19	40	8,5
5,5	16	19	40	9,5
6	16	19	40	10,5
7	16	19	40	13
8	16	19	40	15,5
9	16	19	40	17,5
10	16	19	40	18,5
11	16	19	40	20
12	16	19	40	20
13	16	19	40	28
14	16	19	40	32
15	16	19	40	32
16	16	19	40	32
17	16	19	40	32
18	16	19	40	32
19	16	19	40	32
20	16	19	40	32
22	16	19	40	32
24	16	19	40	32
25	16	19	40	32
26	16	19	40	32
27	16	19	40	32
28	16	19	40	32
29	16	19	40	32
30	16	19	40	32
31	16	19	40	32
32	16	19	40	32

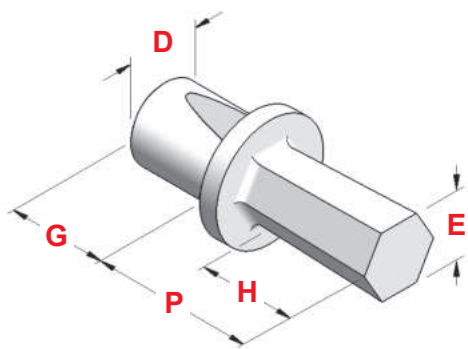

RIVESTIMENTO CONSIGLIATO per MATERIALE da LAVORARE	
SUGGESTED COATING for MATERIAL to WORK	
TiN	ACCIAIO / STEEL - RM ≤ 850 N/mm ²
TiAlN	ACCIAIO / STEEL - RM ≤ 1400 N/mm ²
INOX-PLUS	ACCIAIO INOX / STAINLESS STEEL
	TITANIO / TITANIUM



BROCCE QUADRE
SQUARE BROACHES

Broccia Quadra
Square Broach

Gambo shank
D = 5

Art.
9050

Gambo shank
D = 8

Art.
9051

Gambo shank
D = 12

Art.
9052

Gambo shank
D = 16

Art.
9053

Extended P = 40

Gambo shank
D = 16

Art.
9054

- HSS** ⇨
- TiN** ⇨
- TiAlN** ⇨
- INOX-PLUS** ⇨

9055
9060
9065

9056
9061
9066

9057
9062
9067

9058
9063
9068

9059
—
—

Q	D	G	P	H
1	5	7	10	2
1,5	5	7	10	3
2	5	7	10	4
2,5	5	7	10	5
3	5	7	10	6
3,5	5	7	10	6
4	5	7	10	7

Q	D	G	P	H
1	8	9	18	2
1,5	8	9	18	3
2	8	9	18	5
2,5	8	9	18	6
3	8	9	18	7
3,5	8	9	18	8
4	8	9	18	9
4,5	8	9	18	9
5	8	9	18	11
5,5	8	9	18	11
6	8	9	18	13
7	8	9	18	15
8	8	9	18	15

Q	D	G	P	H
1	12	15	25	2
1,5	12	15	25	3
2	12	15	25	5
2,5	12	15	25	6
3	12	15	25	7
3,5	12	15	25	8
4	12	15	25	9
4,5	12	15	25	9
5	12	15	25	11
5,5	12	15	25	11
6	12	15	25	13
7	12	15	25	15
8	12	15	25	17
9	12	15	25	19
10	12	15	25	21
11	12	15	25	21
12	12	15	25	21
13	12	15	25	21
14	12	15	25	21

Q	D	G	P	H
1	16	19	25	2
1,5	16	19	25	3
2	16	19	25	5
2,5	16	19	25	6
3	16	19	25	7
3,5	16	19	25	8
4	16	19	25	9
4,5	16	19	25	9
5	16	19	25	11
5,5	16	19	25	11
6	16	19	25	13
7	16	19	25	15
8	16	19	25	17
9	16	19	25	19
10	16	19	25	21
11	16	19	25	21
12	16	19	25	21
13	16	19	25	21
14	16	19	25	21
15	16	19	25	21
16	16	19	25	21
17	16	19	25	21
18	16	19	25	21
19	16	19	25	21
20	16	19	25	21
22	16	19	25	21
24	16	19	25	21
25	16	19	25	21
26	16	19	25	21
27	16	19	25	21
28	16	19	25	21
29	16	19	25	21
30	16	19	25	21
31	16	19	25	21
32	16	19	25	21

Q	D	G	P	H
1	16	19	40	2
1,5	16	19	40	3
2	16	19	40	3,5
2,5	16	19	40	4
3	16	19	40	5
3,5	16	19	40	6
4	16	19	40	6,5
4,5	16	19	40	7
5	16	19	40	8,5
5,5	16	19	40	9,5
6	16	19	40	10,5
7	16	19	40	13
8	16	19	40	15,5
9	16	19	40	17,5
10	16	19	40	18,5
11	16	19	40	20
12	16	19	40	20
13	16	19	40	28
14	16	19	40	32
15	16	19	40	32
16	16	19	40	32
17	16	19	40	32
18	16	19	40	32
19	16	19	40	32
20	16	19	40	32
22	16	19	40	32
24	16	19	40	32
25	16	19	40	32
26	16	19	40	32
27	16	19	40	32
28	16	19	40	32
29	16	19	40	32
30	16	19	40	32
31	16	19	40	32
32	16	19	40	32

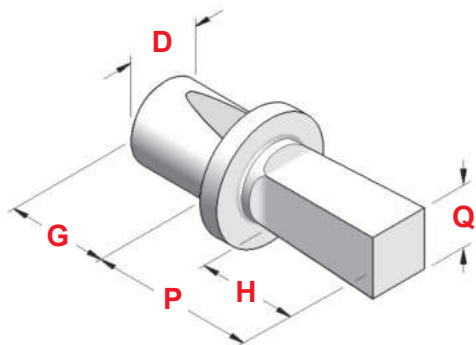

RIVESTIMENTO CONSIGLIATO per MATERIALE da LAVORARE	
SUGGESTED COATING for MATERIAL to WORK	
TiN	ACCIAIO / STEEL - RM ≤ 850 N/mm ²
TiAlN	ACCIAIO / STEEL - RM ≤ 1400 N/mm ²
INOX-PLUS	ACCIAIO INOX / STAINLESS STEEL
	TITANIO / TITANIUM



BROCCE TORX®
TORX® BROACHES



Gambo shank
D = 5

Art.
9029

Gambo shank
D = 8

Art.
9070

Gambo shank
D = 12

Art.
9071

Gambo shank
D = 16

Art.
9072

Extended P = 40

Gambo shank
D = 16

Art.
9073

- HSS ⇨
- TiN ⇨
- TiAlN ⇨
- INOX-PLUS ⇨

9074
9079
9084

9075
9080
9085

9076
9081
9086

9077
9082
9087

9078
—
—

Torx®	D	G	P	H
3	5	7	10	1,2
4	5	7	10	1,2
5	5	7	10	1,5
6	5	7	10	1,7
7	5	7	10	1,7
8	5	7	10	2
9	5	7	10	2
10	5	7	10	2
15	5	7	10	3
20	5	7	10	3,5

Torx®	D	G	P	H
3	8	9	18	1,2
4	8	9	18	1,2
5	8	9	18	1,5
6	8	9	18	1,7
7	8	9	18	1,7
8	8	9	18	2
9	8	9	18	2
10	8	9	18	2
15	8	9	18	3
20	8	9	18	3,5
25	8	9	18	4
27	8	9	18	4
30	8	9	18	4,5
40	8	9	18	5

Torx®	D	G	P	H
3	12	15	25	1,2
4	12	15	25	1,2
5	12	15	25	1,5
6	12	15	25	1,7
7	12	15	25	1,7
8	12	15	25	2
9	12	15	25	2
10	12	15	25	2
15	12	15	25	3
20	12	15	25	3,5
25	12	15	25	4
27	12	15	25	4
30	12	15	25	4,5
40	12	15	25	5
45	12	15	25	5,5
50	12	15	25	6
55	12	15	25	7

Torx®	D	G	P	H
3	16	19	25	1,2
4	16	19	25	1,2
5	16	19	25	1,5
6	16	19	25	1,7
7	16	19	25	1,7
8	16	19	25	2
9	16	19	25	2
10	16	19	25	2
15	16	19	25	3
20	16	19	25	3,5
25	16	19	25	4
27	16	19	25	4
30	16	19	25	4,5
40	16	19	25	5
45	16	19	25	5,5
50	16	19	25	6
55	16	19	25	7
60	16	19	25	7,5

Torx®	D	G	P	H
3	16	19	40	1,2
4	16	19	40	1,2
5	16	19	40	1,5
6	16	19	40	1,7
7	16	19	40	1,7
8	16	19	40	2
9	16	19	40	2
10	16	19	40	2
15	16	19	40	3
20	16	19	40	3,5
25	16	19	40	4
27	16	19	40	4
30	16	19	40	4,5
40	16	19	40	5
45	16	19	40	5,5
50	16	19	40	6
55	16	19	40	7
60	16	19	40	7,5

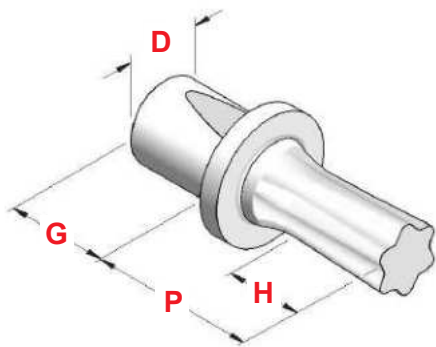

RIVESTIMENTO CONSIGLIATO per MATERIALE da LAVORARE
SUGGESTED COATING for MATERIAL to WORK

TiN	ACCIAIO / STEEL - RM ≤ 850 N/mm ²
TiAlN	ACCIAIO / STEEL - RM ≤ 1400 N/mm ²
INOX-PLUS	ACCIAIO INOX / STAINLESS STEEL
	TITANIO / TITANIUM

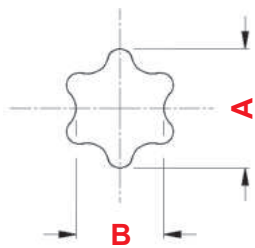

Torx®	3	4	5	6	7	8	9	10	15	20	25	27	30	40	45	50	55	60
A	1,214	1,374	1,449	1,778	2,095	2,418	2,603	2,844	3,378	3,962	4,559	5,118	5,651	6,807	7,975	8,991	11,404	13,487
B	0,884	0,996	1,097	1,293	1,521	1,755	1,889	2,057	2,438	2,857	3,226	3,672	4,065	4,889	5,689	6,502	8,009	9,677



BROCCE TORX PLUS®
TORX PLUS® BROACHES



Gambo shank
D = 5

Art.
9089

Gambo shank
D = 8

Art.
9090

Gambo shank
D = 12

Art.
9091

Gambo shank
D = 16

Art.
9092

Extended P = 40

Gambo shank
D = 16

Art.
9093

HSS ⇒
TiN ⇒
TiAlN ⇒
INOX-PLUS ⇒

9094
9776
9781

9095
9777
9782

9096
9778
9783

9097
9779
9784

9098
—
—

Torx Plus®	D	G	P	H
6	5	7	10	1,7
7	5	7	10	1,7
8	5	7	10	2
9	5	7	10	2
10	5	7	10	2
15	5	7	10	3
20	5	7	10	3,5

Torx Plus®	D	G	P	H
6	8	9	18	1,7
7	8	9	18	1,7
8	8	9	18	2
9	8	9	18	2
10	8	9	18	2
15	8	9	18	3
20	8	9	18	3,5
25	8	9	18	4
27	8	9	18	4
30	8	9	18	4,5
40	8	9	18	5

Torx Plus®	D	G	P	H
6	12	15	25	1,7
7	12	15	25	1,7
8	12	15	25	2
9	12	15	25	2
10	12	15	25	2
15	12	15	25	3
20	12	15	25	3,5
25	12	15	25	4
27	12	15	25	4
30	12	15	25	4,5
40	12	15	25	5
45	12	15	25	5,5
50	12	15	25	6
55	12	15	25	7

Torx Plus®	D	G	P	H
10	16	19	25	2
15	16	19	25	3
20	16	19	25	3,5
25	16	19	25	4
27	16	19	25	4
30	16	19	25	4,5
40	16	19	25	5
45	16	19	25	5,5
50	16	19	25	6
55	16	19	25	7
60	16	19	25	7,5

Torx Plus®	d	G	L	H
10	16	19	40	2
15	16	19	40	3
20	16	19	40	3,5
25	16	19	40	4
27	16	19	40	4
30	16	19	40	4,5
40	16	19	40	5
45	16	19	40	5,5
50	16	19	40	6
55	16	19	40	7
60	16	19	40	7,5

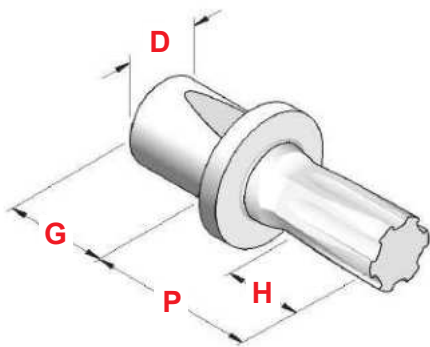

RIVESTIMENTO CONSIGLIATO per MATERIALE da LAVORARE
SUGGESTED COATING for MATERIAL to WORK

TiN	ACCIAIO / STEEL - RM ≤ 850 N/mm ²
TiAlN	ACCIAIO / STEEL - RM ≤ 1400 N/mm ²
INOX-PLUS	ACCIAIO INOX / STAINLESS STEEL
	TITANIO / TITANIUM

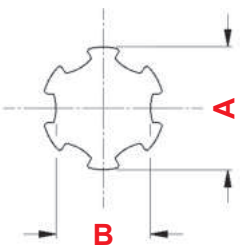

Torx Plus®	6	7	8	9	10	15	20	25	27	30	40	45	50	55	60
A	1,778	2,095	2,418	2,603	2,844	3,378	3,962	4,559	5,118	5,651	6,807	7,975	8,991	11,385	13,442
B	1,381	1,606	1,860	2,014	2,174	2,606	3,088	3,492	3,990	4,391	5,283	6,141	6,923	8,766	10,350

PARAMENTRI DI UTILIZZO BROCCHE
BROACHES USAGE PARAMETERS

Utilizzare l'emulsione durante la brocciatura
Use cooling while broaching

MATERIALE da LAVORARE MATERIAL to WORK			AVANZAMENTI (mm/giro) / FEED (mm/round)								
			Esagonale Hexagonal			Quadro Square			TORX® TORX PLUS®		
Velocità (giri/min) Speed (round/min)			1 ÷ 12	13 ÷ 23	24 ÷ 40	1 ÷ 10	11 ÷ 20	21 ÷ 25	T3 ÷ T6	T7 ÷ T27 IP6 ÷ IP27	T30 ÷ T70 IP30 ÷ IP70
ottone brass	Rm <350 (N/mm²)	600/1800	0,10	0,07	0,04	0,08	0,06	0,04	0,10	0,09	0,07
rame copper	Rm <350 (N/mm²)	700/1900	0,12	0,09	0,05	0,10	0,08	0,06	0,12	0,11	0,09
alluminio aluminium	Rm <500 (N/mm²)	700/2000	0,10-0,14	0,07-0,10	0,04-0,06	0,08-0,12	0,05-0,08	0,02-0,04	0,14	0,12-0,13	0,09-0,12
acciaio steel	Rm <700 (N/mm²)	650/1800	0,10	0,08	0,05	0,06	0,04	0,02	0,10	0,09	0,07
	Rm 700 - 850 (N/mm²)	600/1600	0,08	0,06	0,04	0,05	0,03	0,02	0,08	0,07	0,05
	Rm 850 - 1250 (N/mm²)	500/1400	0,05	0,02	0,01	0,02	0,02	0,01	0,05	0,04	0,03
	Rm 1250 - 1400 (N/mm²)	400/1200	0,02	0,015	0,01	0,02	0,015	0,01	0,03	0,02	0,02
acciaio inox stainless steel	Rm <900 (N/mm²)	600/1600	0,08	0,06	0,04	0,05	0,04	0,02	0,08	0,07	0,06
	Rm >900 (N/mm²)	500/1200	0,04	0,03	0,02	0,03	0,02	0,01	0,045	0,04	0,03
titanio titanium	Rm >700 (N/mm²)	450/1200	0,03	0,02	0,01	0,02	0,02	0,01	0,035	0,03	0,02
ghisa cast iron	Rm <600 (N/mm²)	650/1800	0,10	0,06	0,03	0,08	0,05	0,03	0,10	0,09	0,06

Broccia ESAGONALE  Hexagonal Broach	PRE-FORO PRE-HOLE
1	∅ 1,05 +0,10/0
1,5	∅ 1,55 +0,10/0
2	∅ 2,10 +0,10/0
2,5	∅ 2,60 +0,10/0
3	∅ 3,10 +0,10/0
4	∅ 4,15 +0,10/0
5	∅ 5,15 +0,10/0
6	∅ 6,20 +0,10/0
7	∅ 7,20 +0,15/0
8	∅ 8,25 +0,15/0
9	∅ 9,25 +0,15/0
10	∅ 10,30 +0,15/0
12	∅ 12,35 +0,15/0
13	∅ 13,40 +0,15/0
14	∅ 14,40 +0,15/0
15	∅ 15,45 +0,20/0
16	∅ 16,45 +0,20/0
17	∅ 17,50 +0,20/0
18	∅ 18,55 +0,20/0
19	∅ 19,55 +0,20/0
20	∅ 20,60 +0,20/0
22	∅ 22,65 +0,20/0
24	∅ 24,70 +0,20/0
27	∅ 27,80 +0,25/0
30	∅ 30,90 +0,25/0
32	∅ 33,20 +0,25/0

Broccia QUADRA  Square Broach	PRE-FORO PRE-HOLE
1	∅ 1,15 +0,10/0
2	∅ 2,20 +0,10/0
3	∅ 3,30 +0,10/0
4	∅ 4,40 +0,10/0
5	∅ 5,50 +0,10/0
6	∅ 6,60 +0,10/0
7	∅ 7,70 +0,15/0
8	∅ 8,80 +0,15/0
9	∅ 9,90 +0,15/0
10	∅ 11,00 +0,20/0
11	∅ 12,10 +0,20/0
12	∅ 13,20 +0,20/0
13	∅ 14,30 +0,20/0
14	∅ 15,40 +0,20/0
15	∅ 16,50 +0,20/0
16	∅ 17,60 +0,20/0
17	∅ 18,70 +0,20/0
18	∅ 19,80 +0,20/0
19	∅ 20,90 +0,20/0
20	∅ 22,00 +0,20/0
21	∅ 23,10 +0,25/0
22	∅ 24,20 +0,25/0
23	∅ 25,30 +0,25/0
24	∅ 26,40 +0,25/0
25	∅ 27,50 +0,25/0

Broccia TORX®  TORX® Broach	PRE-FORO PRE-HOLE
T3	∅ 0,95 +0,05/0
T4	∅ 1,05 +0,05/0
T5	∅ 1,20 +0,05/0
T6	∅ 1,40 +0,10/0
T7	∅ 1,60 +0,10/0
T8	∅ 1,90 +0,10/0
T9	∅ 1,95 +0,10/0
T10	∅ 2,20 +0,10/0
T15	∅ 2,60 +0,10/0
T20	∅ 3,00 +0,10/0
T25	∅ 3,40 +0,10/0
T27	∅ 3,80 +0,10/0
T30	∅ 4,15 +0,10/0
T40	∅ 5,00 +0,15/0
T45	∅ 5,80 +0,15/0
T50	∅ 6,70 +0,20/0
T55	∅ 8,20 +0,20/0
T60	∅ 9,85 +0,20/0

Broccia TORX PLUS®  TORX PLUS® Broach	PRE-FORO PRE-HOLE
IP6	∅ 1,50 +0,10/0
IP8	∅ 1,95 +0,10/0
IP9	∅ 2,10 +0,10/0
IP10	∅ 2,30 +0,10/0
IP15	∅ 2,70 +0,10/0
IP20	∅ 3,20 +0,10/0
IP25	∅ 3,60 +0,10/0
IP27	∅ 4,10 +0,10/0
IP30	∅ 4,50 +0,10/0
IP40	∅ 5,40 +0,10/0
IP45	∅ 6,40 +0,10/0
IP50	∅ 7,10 +0,10/0
IP55	∅ 9,20 +0,10/0
IP60	∅ 10,60 +0,20/0

La profondità del pre-foro deve essere di almeno il 20% superiore a quella del profilo da eseguire. Per agevolare la lavorazione si consiglia di eseguire uno smusso di imbocco.

Pre-hole depth must be at least 20% greater than the one of the profile to execute. To facilitate the processing it is recommended to perform an entrance chamfer.

PORTAPINZA E AUTOSERRANTI ATTACCO CILINDRICO

STRAIGHT SHANK COLLET CHUCKS AND MONOLITHIC DRILL CHUCKS

**PORTAPINZA ER
ghiera MINI**
ER MINI NUT
COLLET CHUCKS
pag. 34 - 36



**PORTAPINZA ER DOPPIO
ghiera MINI**
DOUBLE ER MINI NUT
COLLET CHUCKS
pag. 36



**PORTAPINZA ER
ghiera ESAGONALE**
ER HEXAGONAL NUT
COLLET CHUCKS
pag. 37



**PORTAPINZA ER
ghiera STANDARD**
ER STANDARD NUT
COLLET CHUCKS
pag. 38 - 40



**PORTAPINZA ER con
FORI di LUBRIFICAZIONE**
ER COLLET CHUCKS
with COOLING HOLES
pag. 40



**PORTAPINZA ER
con ghiera INTERNA**
ER COLLET CHUCKS
with INNER NUT
pag. 41



**AUTOSERRANTI INTEGRALI
ROTAZIONE DESTRA**
RIGHT SPIN
MONOLITHIC DRILL CHUCKS
pag. 42



**AUTOSERRANTI INTEGRALI
ROTAZIONE DESTRA e SINISTRA**
RIGHT and LEFT SPIN
MONOLITHIC DRILL CHUCKS
pag. 42



PORTAUTENSILI COMBINATI SEMPLICI TORNIRE-FORARE

TURN AND DRILL SIMPLE TOOLHOLDERS

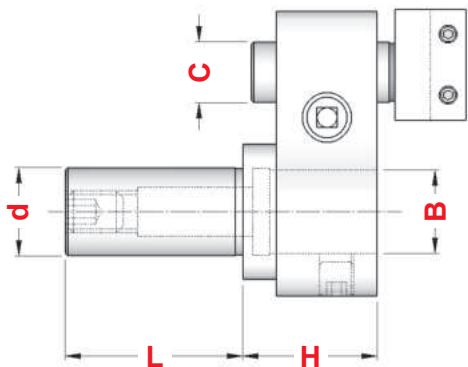

Art.	d	L	H	C	B	
2066	19,05	46	26	15	15	2453
1223	20,00	46	26	15	15	2453
2346	22,00	50	36	18	25	2069
1333	25,00	50	36	18	25	2069
2065	25,40	50	36	18	25	2069
2449	31,75	50	36	18	25	2069
1219	32,00	50	36	18	25	2069

Il portautensile è fornito completo del portabarretta diritto indicato in tabella. Il portabarretta inclinato viene montato su richiesta.



The tool holder is supplied complete with straight toolpost indicated in the table. The inclined toolpost is mounted on request.

Portabarrette DIRITTI

STRAIGHT Toolposts

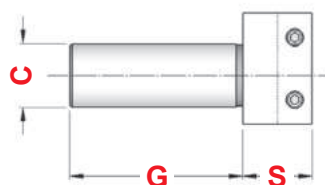

Art.	C	G	S
2453	15	42	18
2783	15	60	18
2069	18	50	20
2785	18	75	20

Portabarrette INCLINATI

INCLINED Toolposts

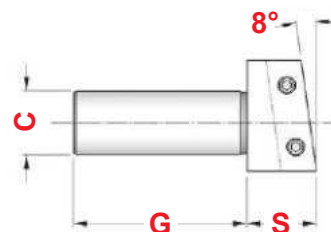

Art.	C	G	S
2454	15	42	18
2864	15	60	18
2070	18	50	24
2876	18	75	25

PORTAUTENSILI COMBINATI SEMPLICI TORNIRE-FORARE

CON PINZA ER

TURN AND DRILL SIMPLE TOOLHOLDERS WITH ER COLLET



Art.	d	L	H	C	RANGE				
2418	19,05	46	34	15	ER20 1÷15	2453	2869	3171	0787
1172	20,00	46	34	15	ER20 1÷15	2453	2869	3171	0787
1679	22,00	50	47	18	ER32 2÷25	2069	2871	3173	0988
1899	25,00	50	47	18	ER32 2÷25	2069	2871	3173	0988
2419	25,40	50	47	18	ER32 2÷25	2069	2871	3173	0988
1968	31,75	50	47	18	ER32 2÷25	2069	2871	3173	0988
1181	32,00	50	47	18	ER32 2÷25	2069	2871	3173	0988

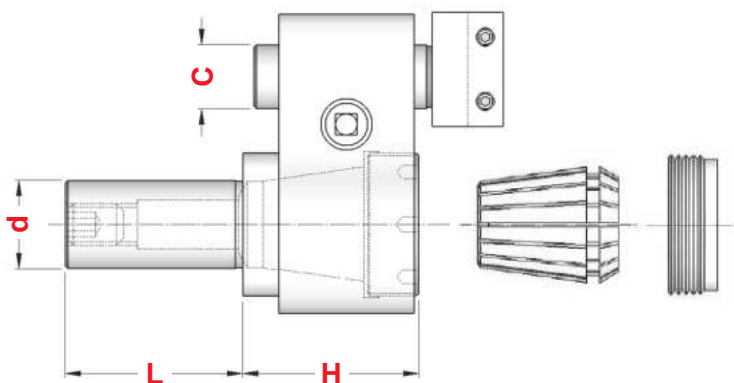

PORTAUTENSILI COMBINATI DOPPI TORNIRE-FORARE

TURN AND DRILL DOUBLE TOOLHOLDERS

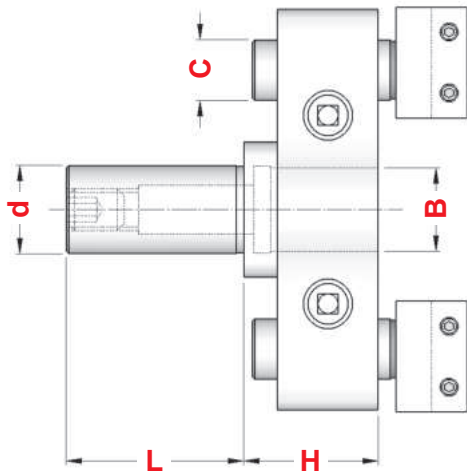

Art.	d	L	H	C	B	
2073	19,05	46	32	15	15	2453
1224	20,00	46	32	15	15	2453
2089	22,00	50	48	18	25	2069
2093	25,00	50	48	18	25	2069
2072	25,40	50	48	18	25	2069
2443	31,75	50	48	18	25	2069
1225	32,00	50	48	18	25	2069

Il portautensile è fornito completo di 2 portabarretta diritti dell'articolo indicato in tabella. I portabarretta inclinati vengono montati su richiesta.



The tool holder is supplied complete with 2 straight toolpost of the article indicated in the table. The inclined toolpost are mounted on request

**PORTAUTENSILI COMBINATI DOPPI TORNIRE-FORARE
CON PINZA ER**

TURN AND DRILL DOUBLE TOOLHOLDERS WITH ER COLLET

Art.	d	L	H	C	RANGE				
2504	19,05	46	34	15	ER20 1÷15	2453	2869	3171	0787
1183	20,00	46	34	15	ER20 1÷15	2453	2869	3171	0787
1969	22,00	50	47	18	ER32 2÷25	2069	2871	3173	0988
1970	25,00	50	47	18	ER32 2÷25	2069	2871	3173	0988
2505	25,40	50	47	18	ER32 2÷25	2069	2871	3173	0988
2078	31,75	50	47	18	ER32 2÷25	2069	2871	3173	0988
1199	32,00	50	47	18	ER32 2÷25	2069	2871	3173	0988

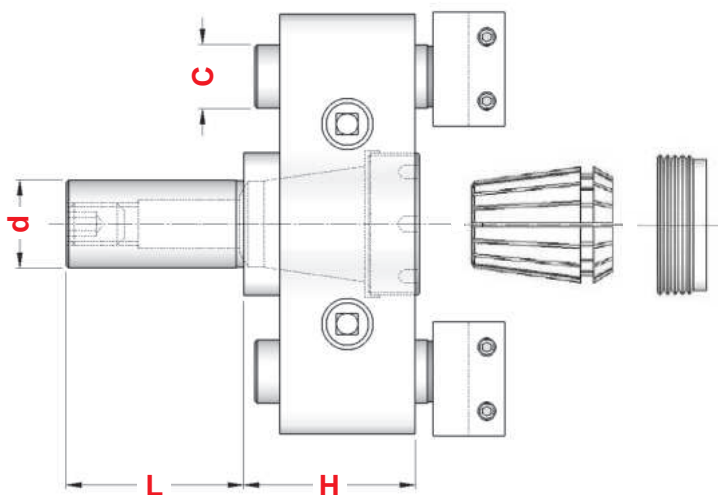

PORTAUTENSILI REGISTRABILI PER INTERNI
ADJUSTABLE TOOLHOLDERS FOR INNER WORKING

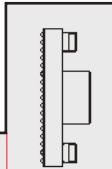

Art.	d	L	H	B	CORSA STROKE
1501	16,00	32	46,5	12	10
1701	19,05	50	54	15	18
1868	20,00	50	54	15	18
1870	25,00	50	54	18	18
1871	25,40	50	54	18	18

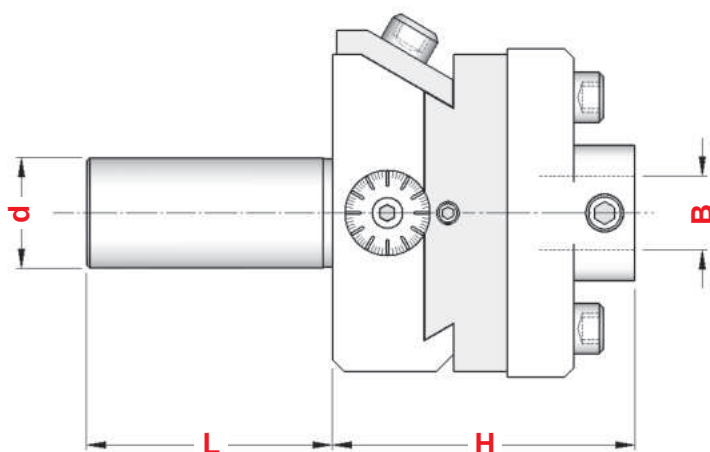

**PORTAUTENSILI REGISTRABILI PER INTERNI
CON PINZA ER**

ADJUSTABLE TOOLHOLDERS FOR INNER WORKING WITH ER COLLET

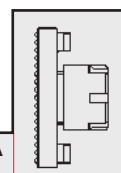

Art.	d	L	H	A	RANGE	CORSA STROKE
1662	19,05	50	70	28	ER 20 1÷15	18
1664	20,00	50	70	28	ER 20 1÷15	18
1666	25,00	50	75	35	ER 25 1÷20	18
1672	25,40	50	75	35	ER 25 1÷20	18

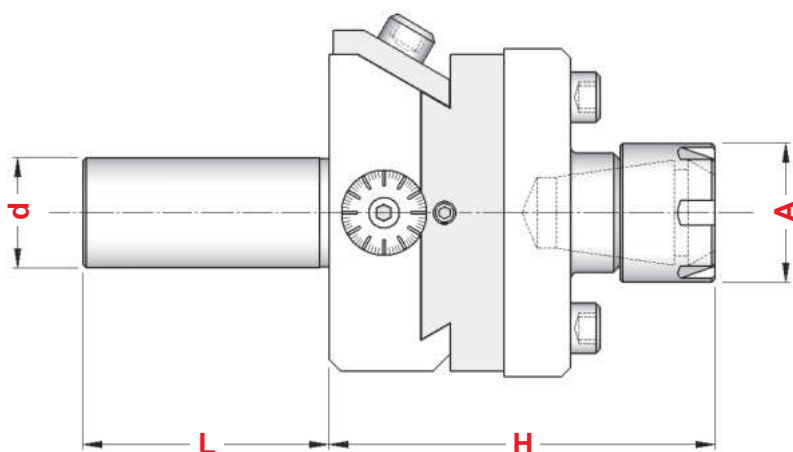

PORTAUTENSILI PER RECESSI INTERNI
 TOOLHOLDERS FOR INNER RECESSES

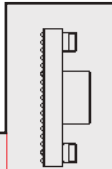

Art.	d	L	H	B	CORSA STROKE	
2497	19,05	46	52	15	20	2987
1559	20,00	46	52	15	20	2987
2498	25,00	50	60	18	24	2988
2499	25,40	50	60	18	24	2988
2399	31,75	50	60	18	24	2988
1961	32,00	50	60	18	24	2988

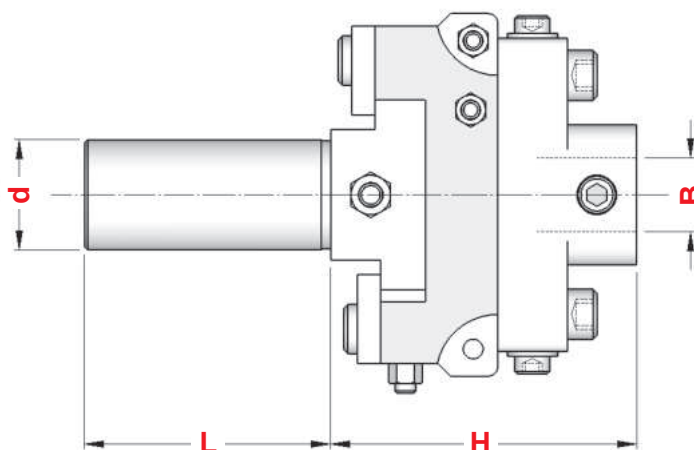

**PORTAUTENSILI PER RECESSI INTERNI
 CON PINZA ER**
 TOOLHOLDERS FOR INNER RECESSES WITH ER COLLET

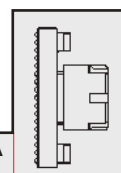

Art.	d	L	H	A	RANGE	CORSA STROKE				
1943	19,05	46	68	28	ER 20 1÷15	20	2989	1230	5720	0787
1766	20,00	46	68	28	ER 20 1÷15	20	2989	1230	5720	0787
2003	25,00	50	82	35	ER 25 1÷20	24	2990	1231	5721	0996
2023	25,40	50	82	35	ER 25 1÷20	24	2990	1231	5721	0996
2024	31,75	50	82	35	ER 25 1÷20	24	2990	1231	5721	0996
2032	32,00	50	82	35	ER 25 1÷20	24	2990	1231	5721	0996

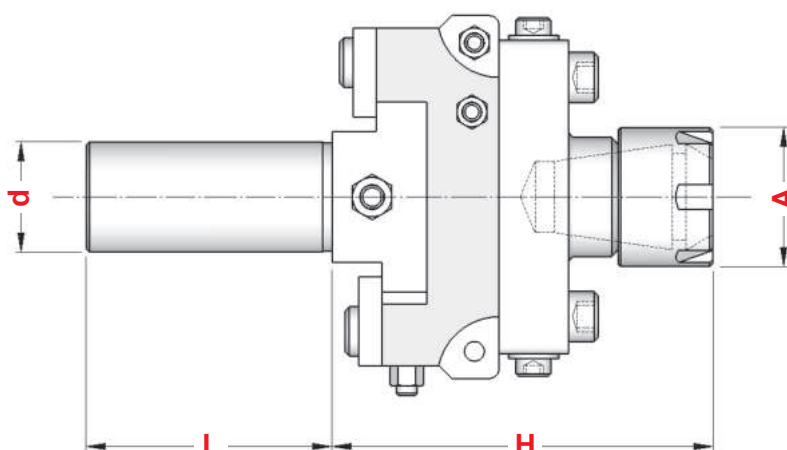

PORTAUTENSILI TRASVERSALI PER INDEX E TRAUB

CROSSWISE TOOLHOLDERS FOR INDEX AND TRAUB

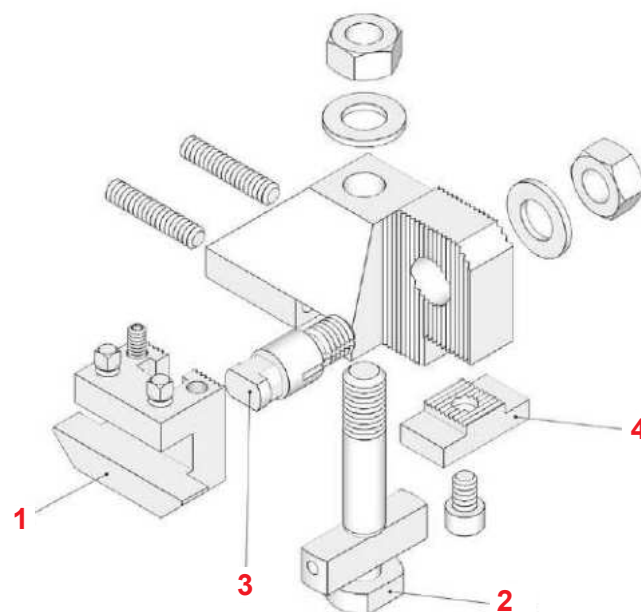
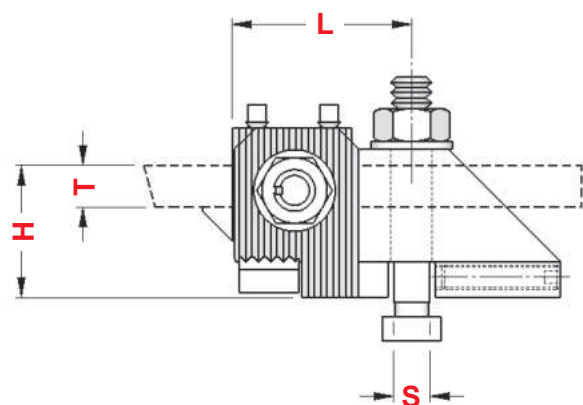

INDEX 12 - 18 - 25 TRAUB TD.16 - 26 - 36

Art.	L	H min	H max	T	S
1880	46	16	32	10 x 10	10

RICAMBI / SPARES

Pos.	Art.	DESCRIZIONE
1	2105	Portabarretta Semplice
2	2308	Perno di fissaggio Portautensile
3	2309	Perno di fissaggio Portabarretta
4	2753	Tassello di battuta

INDEX 24 - 29 - 36 - 42 INDEX B.30 - 42

Art.	L	H min	H max	T	S
1317	60	19	42	14 x 14	12

RICAMBI / SPARES

Pos.	Art.	DESCRIZIONE
1	1984	Portabarretta Semplice
2	1986	Perno di fissaggio Portautensile
3	1987	Perno di fissaggio Portabarretta
4	2754	Tassello di battuta

INDEX 52 - 60 INDEX B.60

Art.	L	H min	H max	T	S
2703	60	19	42	14 x 14	14

RICAMBI / SPARES

Pos.	Art.	DESCRIZIONE
1	1984	Portabarretta Semplice
2	2285	Perno di fissaggio Portautensile
3	1987	Perno di fissaggio Portabarretta
4	2754	Tassello di battuta

TRAUB TB.30 - 42 - 60

Art.	L	H min	H max	T	S
2707	60	19	42	14 x 14	15

RICAMBI / SPARES

Pos.	Art.	DESCRIZIONE
1	1984	Portabarretta Semplice
2	2397	Perno di fissaggio Portautensile
3	1987	Perno di fissaggio Portabarretta
4	2754	Tassello di battuta

PORTABARRETTE PER PORTAUTENSILI TRASVERSALI - TOOLPOSTS FOR CROSSWISE TOOLHOLDERS

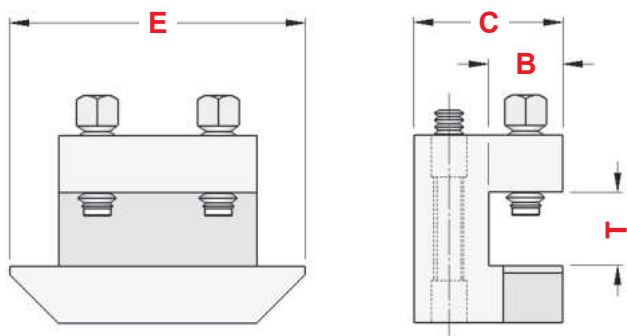

Art.	T	B	E	H	PASSO	UTENSILE
2105	10,5	10	47	22	1,5	10 x 10
2353	10,5	20,5	48	37,5	1,5	10 x 20
1984	15	15	60	30	1,5	14 x 14
1985	15	28,5	60	45	1,5	14 x 20
2662	16,1	32,1	64	52,5	1,5	16 x 32

PERNI DI FISSAGGIO PORTABARRETTE - LOCKING PINS FOR TOOLPOSTS

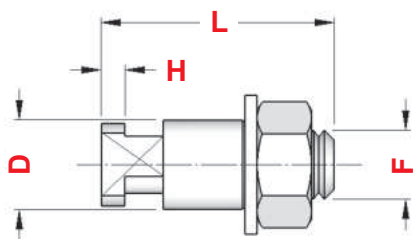

Art.	F	D	L	H
2309	M 10	14	36,5	4
1987	M 14	18	47	4,5

PERNI DI FISSAGGIO PORTAUTENSILI TRASVERSALI - LOCKING PINS FOR CROSSWISE TOOLHOLDERS

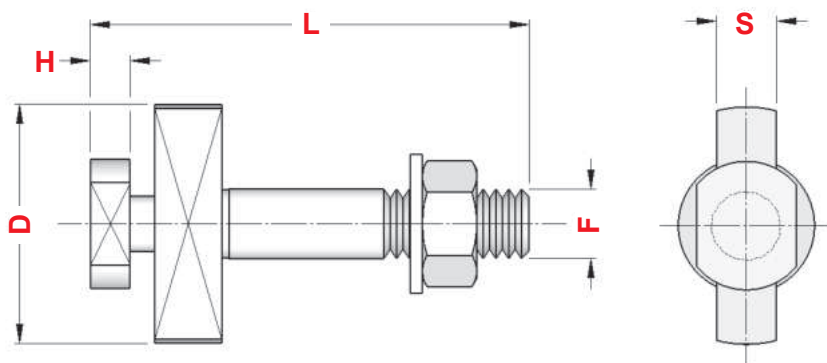

Art.	S	F	L	H	D
2308	10	M 10	59	5	29
1986	12	M 14	88	8	48
2285	14	M 14	88	8	48
2397	15	M 14	88	8	48

TASSELLI DI BATTUTA PER PORTAUTENSILI TRASVERSALI - DOWELS FOR CROSSWISE TOOLHOLDERS

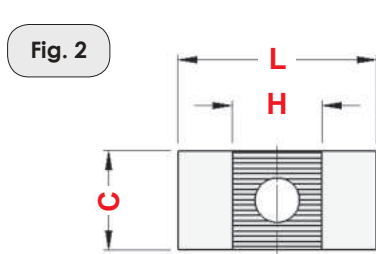
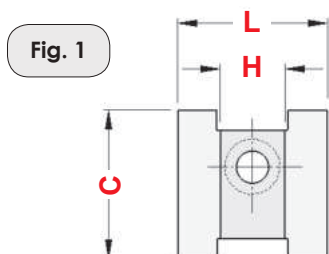

Art.	L	C	H	Fig.
2753	30	22	13	1
2754	40	20	18	2

PORTAUTENSILI PER CARRELLI VERTICALI INDEX

INDEX TOOLPOSTS FOR VERTICAL SLIDES

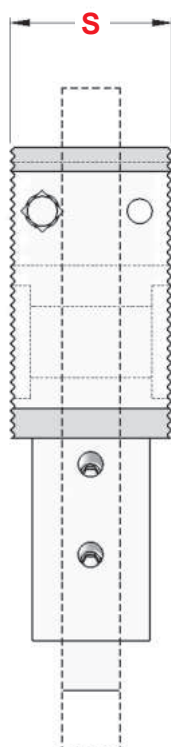
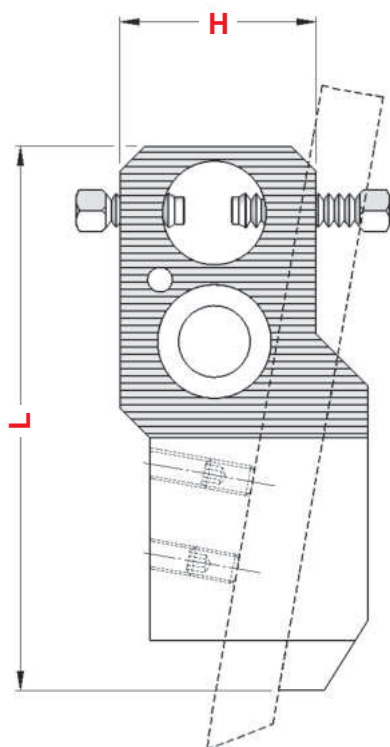

INDEX 12 - 18 - 25 - DG.12
DO.12 - ER.16 - ER.25

Art.	L	H	S	UTENSILE
2583	82	35	26	Quadro (10 x 10)
2588	82	35	20	Piatto (10 x 4)

INDEX B.30 - 42 - 60 - C.29

Art.	L	H	S	UTENSILE
2585	105	50	32	Quadro (14 x 14)

PORTAUTENSILI PER CARRELLI VERTICALI TRAUB , SAIC E STROHM

TOOLHOLDERS FOR TRAUB, SAIC AND STROHM VERTICAL SLIDES

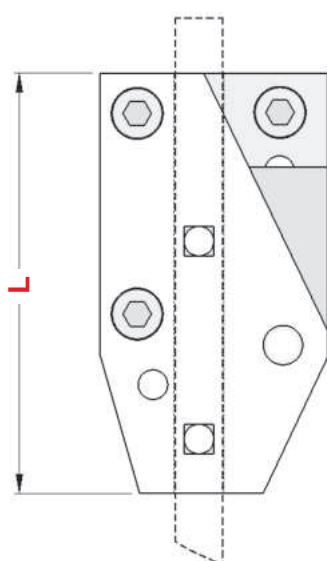

TRAUB A.15 - 20 - 25

Art.	L	S	UTENSILE
1456	85	22	10 x 10

TRAUB TD.16 - 26 - 36

Art.	L	S	UTENSILE
2755	85	22	10 x 10

TRAUB A.26 - 36 - 42 - 60
TB.30 - 42 - 60

Art.	L	S	UTENSILE
1458	102	25	12 x 12

STROHM 125

Art.	L	S	UTENSILE
2620	80	19	8 x 8

SAIC B.26 - 30

Art.	L	S	UTENSILE
1594	85	22	10 x 10

SAIC B.45

Art.	L	S	UTENSILE
1372	105	28	12 x 12

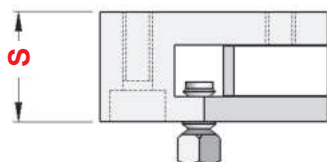

PORTAUTENSILI TRASVERSALI ANTERIORI - TIPO FISSO CHIUSO

FORE TOOLHOLDERS FOR CROSS SLIDE - FIXED CLOSED TYPE

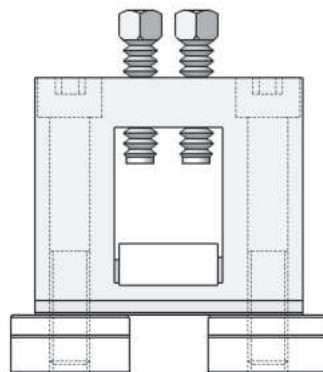
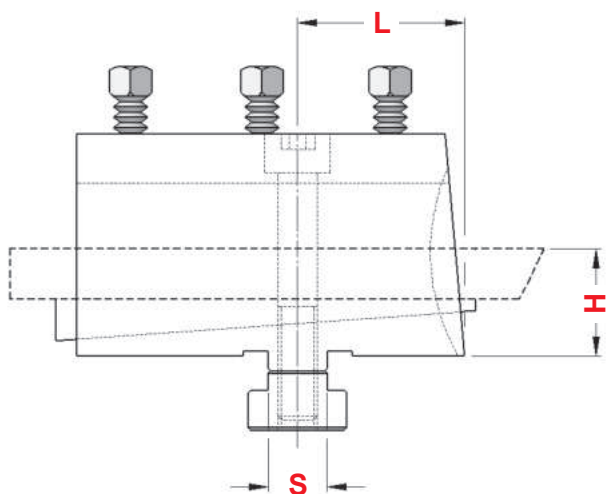

TRAUB A.15 - 20 - 25
GIORGI GM.20 - 25 - 32
ITS 26 - SAIC B.26 - 30

TRAUB A.26 - 36 - 42 - 60
TRAUB TB.30 - 42 - 60
ITS 60 - SAIC B.45

Art.	TIPO	H	L	S	UTENSILE
1291	DOPPIO / Double	22	38	12	10 x 20
1295	TRIPLO / Triple	22	38	12	10 x 30

Art.	TIPO	H	L	S	UTENSILE
1293	DOPPIO / Double	40	65	15	12 x 25
1297	TRIPLO / Triple	40	65	15	12 x 40

PORTAUTENSILI TRASVERSALI POSTERIORI - TIPO FISSO CHIUSO

REAR TOOLHOLDERS FOR CROSS SLIDE - FIXED CLOSED TYPE

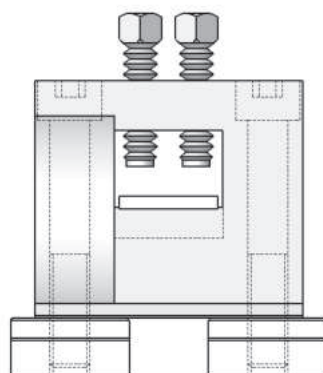
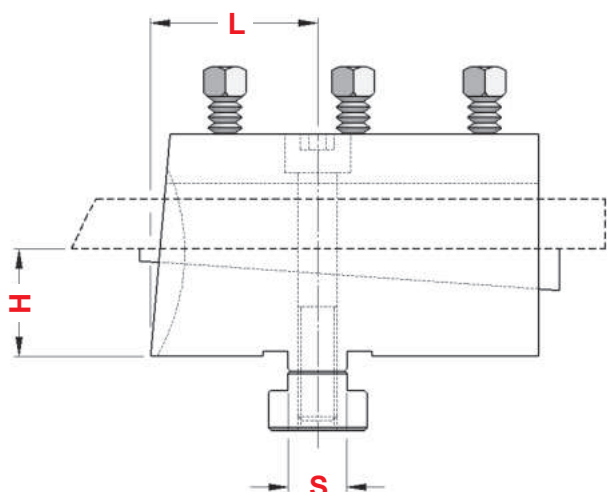

TRAUB A.15 - 20 - 25
GIORGI GM.20 - 25 - 32
ITS 26 - SAIC B.26 - 30

TRAUB A.26 - 36 - 42 - 60
TRAUB TB.30 - 42 - 60
ITS 60 - SAIC B.45

Art.	TIPO	H	L	S	UTENSILE
1292	DOPPIO / Double	22	38	12	10 x 20
1296	TRIPLO / Triple	22	38	12	10 x 30

Art.	TIPO	H	L	S	UTENSILE
1294	DOPPIO / Double	40	65	15	12 x 25
1298	TRIPLO / Triple	40	65	15	12 x 40

PORTAUTENSILI TRASVERSALI ANTERIORI - TIPO OSCILLANTE CHIUSO

FORE TOOLHOLDERS FOR CROSS SLIDE - SWINGING CLOSED TYPE

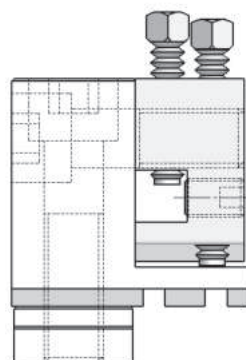
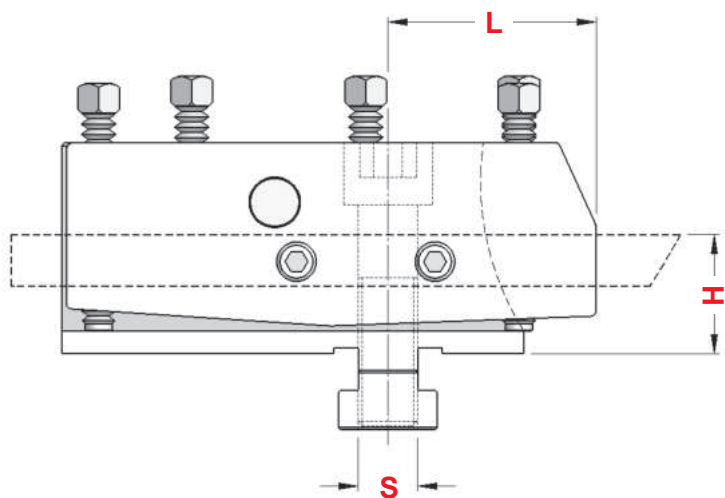

TRAUB A.15 - 20 - 25
ITS 26 - SAIC B.26

Art.	H	L	S	UTENSILE
1007	22	41	12	10 x 10

TRAUB A.26 - 36 - 42 - 60
TRAUB TB.30 - 42 - 60
ITS 60 - SAIC B.45

Art.	H	L	S	UTENSILE
1009	40	62	15	12 x 12

PORTAUTENSILI TRASVERSALI POSTERIORI - TIPO OSCILLANTE CHIUSO

REAR TOOLHOLDERS FOR CROSS SLIDE - SWINGING CLOSED TYPE

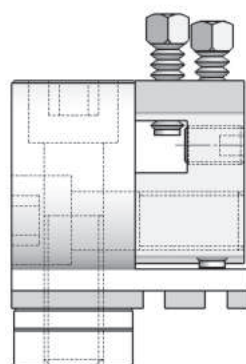
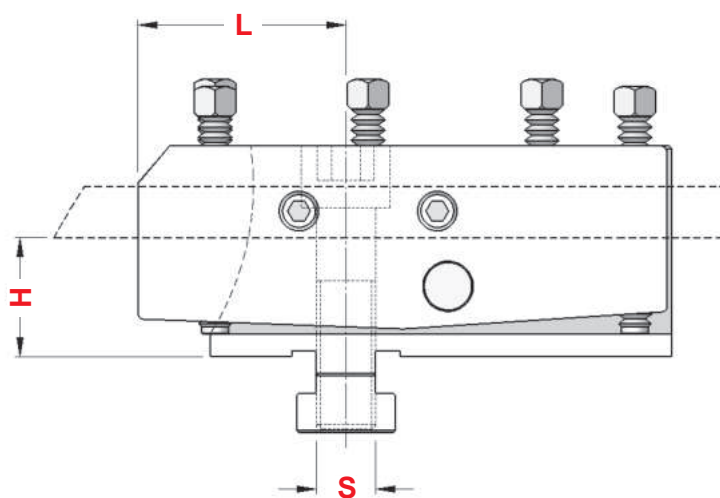

TRAUB A.15 - 20 - 25
ITS 26 - SAIC B.26

Art.	H	L	S	UTENSILE
1008	22	41	12	10 x 10

TRAUB A.26 - 36 - 42 - 60
TRAUB TB.30 - 42 - 60
ITS 60 - SAIC B.45

Art.	H	L	S	UTENSILE
1010	40	62	15	12 x 12

PORTAUTENSILI TRASVERSALI ANTERIORI - TIPO OSCILLANTE APERTO

FORE TOOLHOLDERS FOR CROSS SLIDE - SWINGING OPEN TYPE

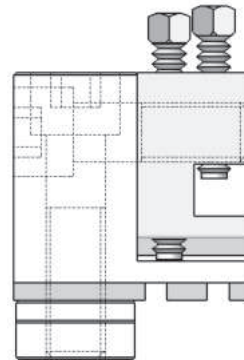
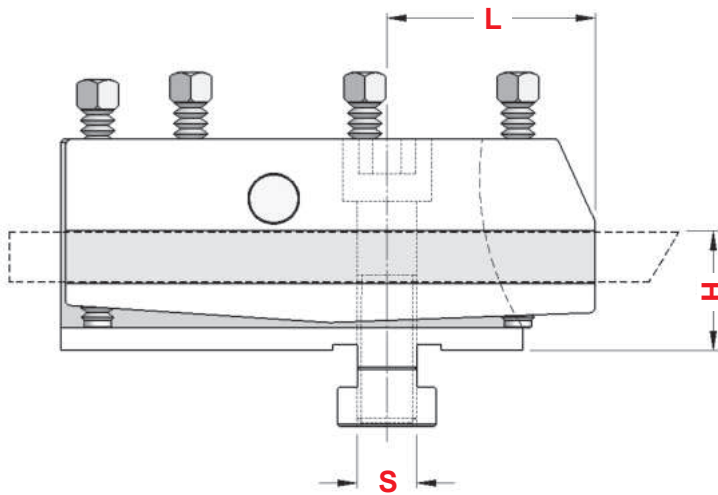

TRAUB A.15 - 20 - 25
ITS 26 - SAIC B.26

Art.	TIPO	H	L	S	UTENSILE
1322	SEMPLICE / Simple	22	41	12	10 x 10
1330	DOPPIO / Double	22	41	12	10 x 20

TRAUB A.26 - 36 - 42 - 60
TRAUB TB.30 - 42 - 60
ITS 60 - SAIC B.45

Art.	TIPO	H	L	S	UTENSILE
2481	SEMPLICE / Simple	40	62	15	12 x 12
2487	DOPPIO / Double	40	62	15	12 x 25

PORTAUTENSILI TRASVERSALI POSTERIORI - TIPO OSCILLANTE APERTO

REAR TOOLHOLDERS FOR CROSS SLIDE - SWINGING OPEN TYPE

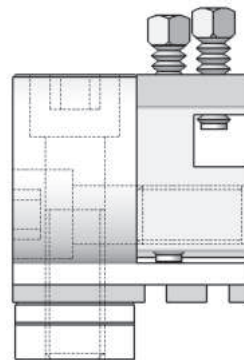
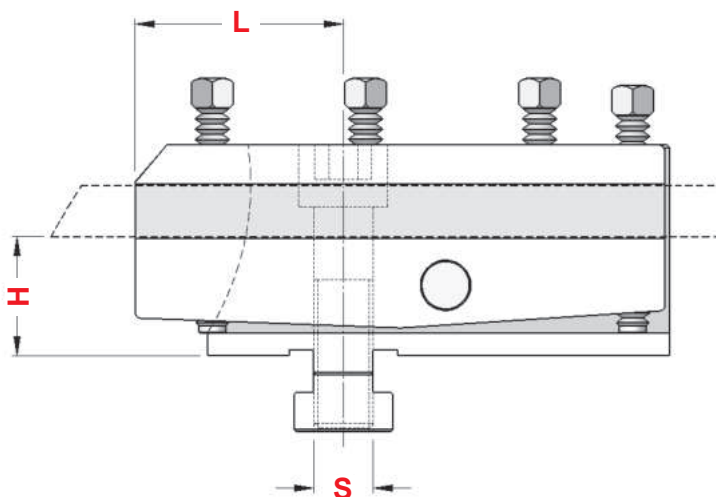

TRAUB A.15 - 20 - 25
ITS 26 - SAIC B.26

Art.	TIPO	H	L	S	UTENSILE
1323	SEMPLICE / Simple	22	41	12	10 x 10
1331	DOPPIO / Double	22	41	12	10 x 20

TRAUB A.26 - 36 - 42 - 60
TRAUB TB.30 - 42 - 60
ITS 60 - SAIC B.45

Art.	TIPO	H	L	S	UTENSILE
2482	SEMPLICE / Simple	40	62	15	12 x 12
2489	DOPPIO / Double	40	62	15	12 x 25

TASSELLI DI BLOCCAGGIO PER PORTAUTENSILI

LOCKING DOWELS FOR TOOLHOLDERS

MACCHINA	Art.	f	E	S
GIORGI GM.20 - 25 - 32	1149	M 10	20	12
	1150	M 12	20	12
ITS 26	1149	M 10	20	12
	1150	M 12	20	12
ITS 36 - 42 - 60	1131	M 10	22	15
	1667	M 12	22	15
	1591	M 14	22	15
SAIC B.26 - 30	1149	M 10	20	12
	1150	M 12	20	12
SAIC B.45	1131	M 10	22	15
	1667	M 12	22	15
	1591	M 14	22	15
TRAUB A.15 - 20 - 25	1149	M 10	20	12
	1150	M 12	20	12
TRAUB A.36 - 42 - 60	1131	M 10	22	15
	1667	M 12	22	15
	1591	M 14	22	15

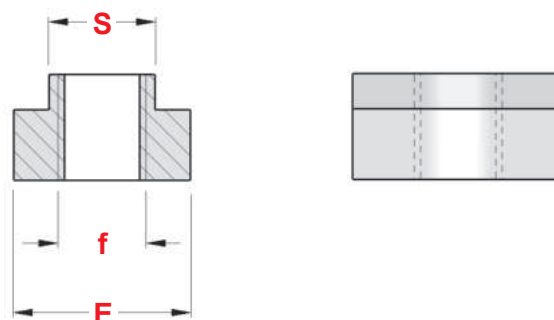

BIETTE PER PORTAUTENSILI

WEDGES FOR TOOLHOLDERS

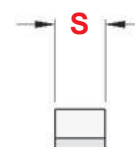
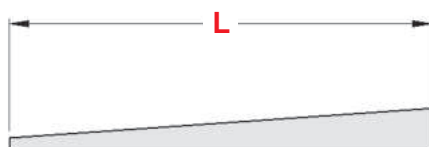

TRAUB A.15 - 20 - 25
GIORGI GM.20 - 25 - 32
ITS 26 - SAIC B. 26 - 30

Art.	S	L
1170	10	85
1536	20	85
2029	30	85

TRAUB A.26 - 36 - 42 - 60
TRAUB TB.30 - 42 - 60
TRAUB TD.16 - 26 - 36
ITS 60 - SAIC B.45

Art.	S	L
1656	15	120
1576	25	120
1828	40	120

VITI A TESTA QUADRA
SQUARE HEADED SCREWS

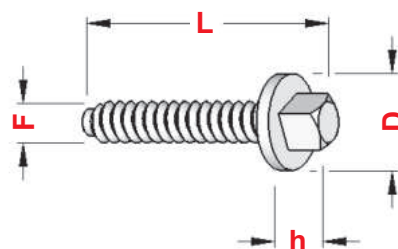
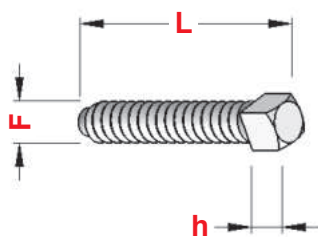

SENZA COLLARE - WITHOUT COLLAR

Art.	F	L	h
2148 - 5x15	M 5	15	5
2148 - 6x15	M 6	15	6
2148 - 6x20	M 6	20	6
2148 - 6x30	M 6	30	6
2148 - 6x42	M 6	42	6
2148 - 6x50	M 6	50	6
2148 - 7x17	M 7	17	6
2148 - 7x21	M 7	21	6
2148 - 7x32	M 7	32	6
2148 - 7x40	M 7	40	6
2148 - 7x50	M 7	50	6
2148 - 7x60	M 7	60	6
2148 - 7x76	M 7	76	6
2148 - 8x20	M 8	20	6
2148 - 8x30	M 8	30	6
2148 - 8x40	M 8	40	6
2148 - 8x50	M 8	50	6
2148 - 8x60	M 8	60	6
2148 - 8x80	M 8	80	6

CON COLLARE - WITH COLLAR

Art.	F	L	D	h
2149 - 6x18	M 6	18	10	9
2149 - 6x30	M 6	30	10	9
2082 - 6x15	M 6	15	14	6
2082 - 6x20	M 6	20	14	6

PASTIGLIE IN OTTONE
BRASS TABLETS



Art.	d	Filetto
0123	5	M 6
1980	6	M 7
1981	6,5	M 8
1982	8,5	M 10

CHIAVE A "PIPA"
"PIPE" TYPE WRENCH

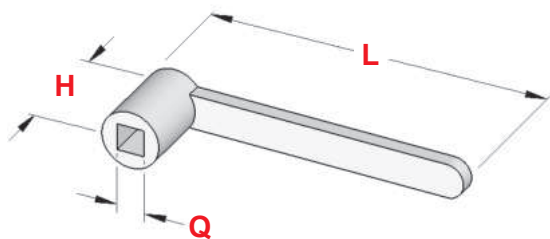

Art.	Q	H	L
1901	6	22	73
1902	8	22	83

CHIAVE A "T"
"T" TYPE WRENCH

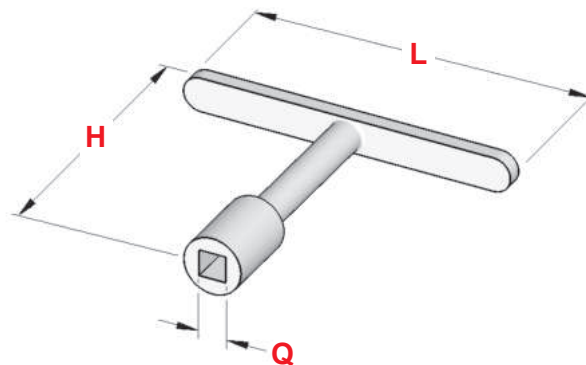

Art.	Q	H	L
1903	6	80	73
1904	8	85	83

UTENSILI SALDOBRASATI CON METALLO DURO PER PASSATA

BRAZED WELDED CARBIDE TOOLS FOR TURNING

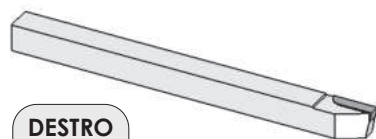

DESTRO
RIGHT

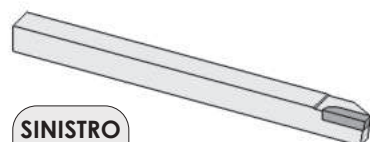

SINISTRO
LEFT

STELO	Destro Right Art.	Sinistro Left Art.	L	PLACCHETTA GRADO 895 
7 x 7	9252	9262	140	20 x 3 x 2
8 x 8	9253	9263	140	20 x 3 x 2
10 x 10	9254	9264	150	20 x 4 x 2,5
12 x 12	9255	9265	150	20 x 4 x 2,5
14 x 14	9256	9266	150	20 x 5 x 3
16 x 16	9257	9267	150	20 x 5 x 3

CON PLACCHETTA MAGGIORATA

10 x 10	9259	9269	150	20 x 5 x 3
12 x 12	9260	9270	150	20 x 5 x 3

UTENSILI SALDOBRASATI CON METALLO DURO FRONTALE A INCASSO - TUFFO

BRAZED WELDED CARBIDE TOOLS FOR AXIAL TURNING

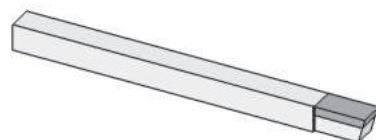

PLACCHETTA
GRADO 883



STELO	Art.	L	
8 x 8	9271	140	16 x 8 x 2
10 x 10	9272	150	18 x 10 x 2,5
12 x 12	9273	150	20 x 12 x 3
14 x 14	9274	150	19 x 14 x 3,5
16 x 16	9275	150	19 x 16 x 4
20 x 20	9276	150	20 x 20 x 5
25 x 25	9277	150	20 x 25 x 6

UTENSILI SALDOBRASATI CON METALLO DURO A TRONCARE

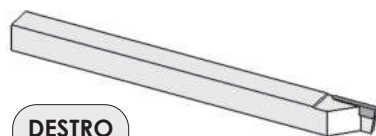
BRAZED WELDED CARBIDE TOOLS FOR PARTING-OFF AND GROOVING

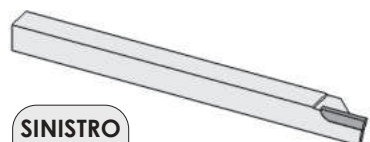

DESTRO
RIGHT



SINISTRO
LEFT

STELO	Destro Right Art.	Sinistro Left Art.	L	PLACCHETTA GRADO 883 
7 x 7	9282	9292	140	20 x 3 x 2
8 x 8	9283	9293	140	20 x 3 x 2
10 x 10	9284	9294	150	20 x 4 x 2,5
12 x 12	9285	9295	150	20 x 4 x 2,5
14 x 14	9286	9296	150	20 x 5 x 3
16 x 16	9287	9297	150	20 x 5 x 3
20 x 20	9288	9298	150	20 x 6 x 3

BARRETTE IN ACCIAIO SUPER RAPIDO **TENAX**

RODS IN HIGH SPEED STEEL

Il marchio TENAX produce barrette trattate e rettificate. La gamma presentata comprende acciai con diverso tenore di Cobalto per rispondere alle differenti esigenze di lavorazione, velocità e tipologie di materiale. Scegliete il vostro tipo di barretta tra TENAX 1 o 2.

TENAX brand produces hardened and grinded rods. Presented range includes steels with different titer in Cobalt to meet the different working needs, speeds and materials.

Chose your kind of rod between TENAX 1 or 2.

TIPO	% Cobalto	% Vanadio
TENAX 1	10,5	3,2
TENAX 2	9	1,2

Barrette quadre

Gamma da Q. 4 a Q. 30
Lunghezza mm 150 , mm 200

Square Rods

Range from square 4 to square 30
Length mm 150, mm 200

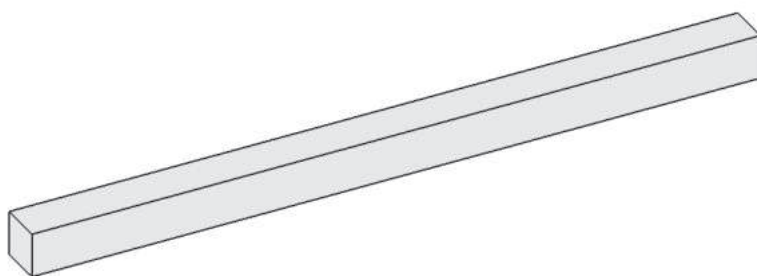
**Barrette piatte**

Gamma da 8x6 a 40x30
Lunghezza mm 200

Flat Rods

Range from 8x6 to 40x30
Length mm 200

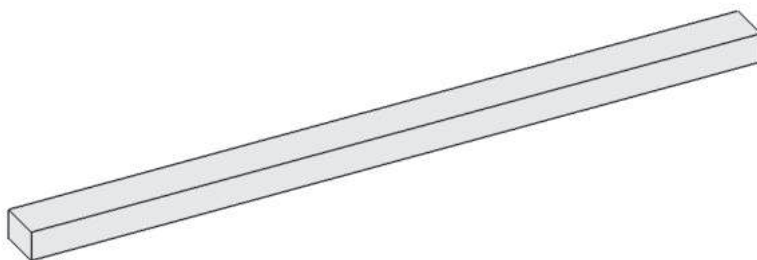
**Barrette tonde**

Gamma da \varnothing 3 a \varnothing 30
Lunghezza mm 100, mm 150 e mm 200

Round Rods

Range from \varnothing 3 to \varnothing 30
Length mm 100, mm 150 and mm 200

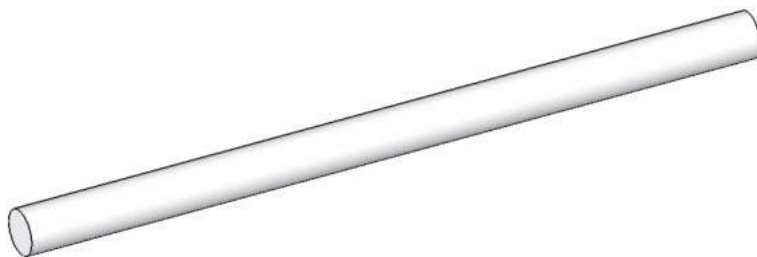
**Barrette trapezoidali / Lame**

Gamma da 10x3x2 a 30x6x5
Lunghezza mm 200

Trapezoidal Rods / Cutting off tools

Range from 10x3x2 to 30x6x5
Length mm 200

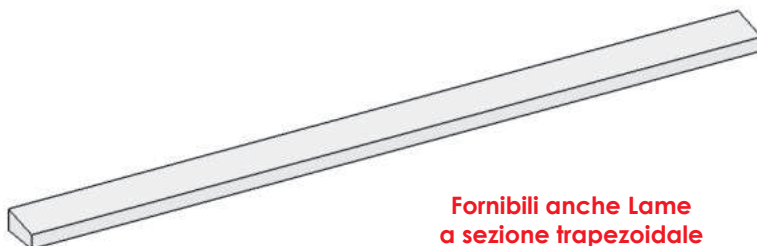

**Fornibili anche Lame
a sezione trapezoidale
compatibili con morsetti MLT**

*Also available Cutting off tools
with trapezoidal section compatible
with MLT holder*

PORTAGODRONI PER RICALCO CON STELO QUADRO

SQUARE SHANK KNURLING-WHEEL HOLDERS

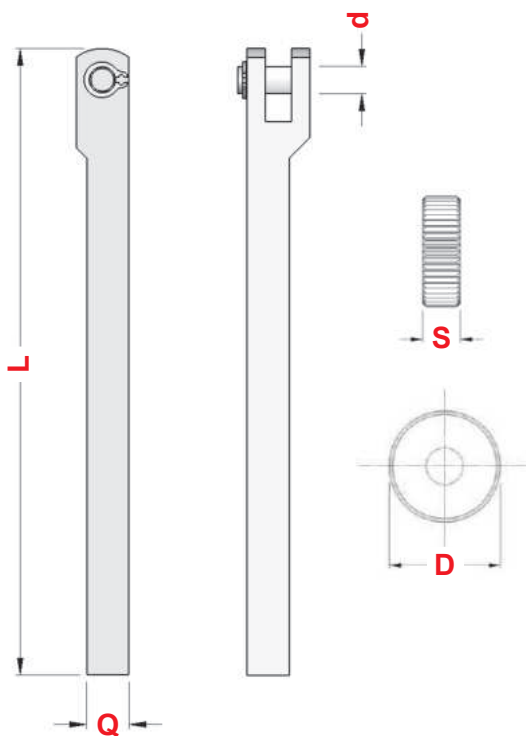
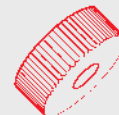

Art.	Q	L	D	d	S	PERNO	GODRONE
1280	6 x 6	120	12	4	4	0094	12 x 4 foro ø4
1281	6 x 6	120	15	5	5	0204	15 x 5 foro ø5
1282	7 x 7	120	12	4	4	0094	12 x 4 foro ø4
1283	7 x 7	120	15	5	5	0204	15 x 5 foro ø5
1284	8 x 8	120	12	4	4	0094	12 x 4 foro ø4
1285	8 x 8	120	15	5	5	0204	15 x 5 foro ø5
1352	10 x 10	120	12	4	4	0094	12 x 4 foro ø4
1286	10 x 10	120	15	5	5	0204	15 x 5 foro ø5
1410	10 x 10	120	20	6	6	0267	20 x 6 foro ø6
1287	10 x 10	120	20	6	8	0267	20 x 8 foro ø6
1411	10 x 10	120	20	6	10	0096	20 x 10 foro ø6
1360	12 x 12	120	15	5	5	0204	15 x 5 foro ø5
1362	12 x 12	120	20	6	6	0267	20 x 6 foro ø6
1288	12 x 12	120	20	6	8	0267	20 x 8 foro ø6
1363	12 x 12	120	20	6	10	0096	20 x 10 foro ø6
1364	16 x 16	120	20	6	8	0267	20 x 8 foro ø6
1371	16 x 16	120	20	6	10	0267	20 x 10 foro ø6
1381	20 x 20	120	20	6	8	0267	20 x 8 foro ø6
1461	20 x 20	120	20	6	10	0096	20 x 10 foro ø6

PORTAGODRONI PER RICALCO CON STELO QUADRO - DISASSATI

MISALIGNED SQUARE SHANK KNURLING-WHEEL HOLDERS

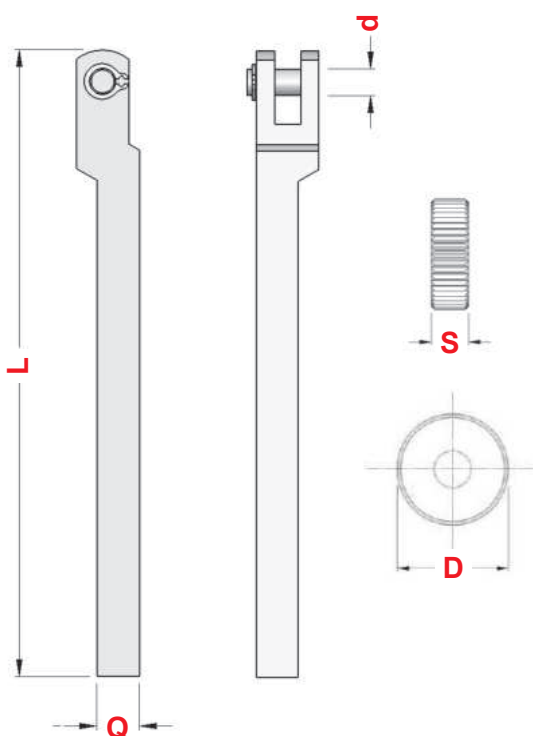
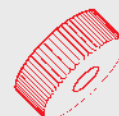

Art.	Q	L	D	d	S	PERNO	GODRONE
2112	8 x 8	120	15	5	5	0204	15 x 5 foro ø5
2113	10 x 10	120	15	5	5	0204	15 x 5 foro ø5
2114	10 x 10	130	20	6	8	0267	20 x 8 foro ø6
2115	12 x 12	130	20	6	8	0267	20 x 8 foro ø6

PERNI PER PORTAGODRONI
PINS FOR KNURLING-WHEEL HOLDERS

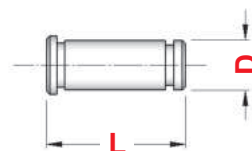

Art.	d	L
0094	4	14
0204	5	14
0267	6	18
0096	6	20

GODRONI SPORGENTI IN ACCIAIO SINTERIZZATO PER LAVORAZIONI A RICALCO

SINTERED STEEL KNURLING WHEELS FOR TRACING WORKING

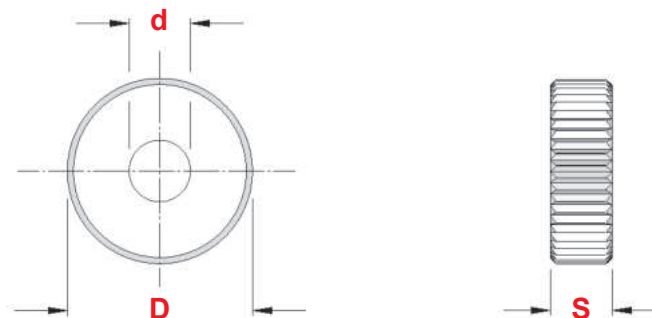

	TIPO	Dimensioni D x S x d	Art.	Passo - Step
	DIRITTO <i>Straight</i>	8 x 4 x 3	9101	0,4
		10 x 4 x 4	9103	0,5 - 0,6 - 0,7 - 0,8 - 0,9
		12 x 4 x 4	9104	1,0 - 1,2 - 1,5
		15 x 4 x 4	9105	
		15 x 5 x 5	9107	
		20 x 6 x 6	9108	0,5 - 0,6 - 0,7 - 0,8 - 0,9
		20 x 8 x 6	9109	1,0 - 1,2 - 1,5 - 2,0
	20x10x 6	9110		
	DESTRO 45° <i>Right</i>	10 x 4 x 4	9113	0,5 - 0,6 - 0,7 - 0,8 - 0,9
		12 x 4 x 4	9114	
		15 x 4 x 4	9115	
		15 x 5 x 5	9117	1,0 - 1,2 - 1,5
		20 x 6 x 6	9118	0,5 - 0,6 - 0,7 - 0,8 - 0,9
		20 x 8 x 6	9119	
	20x10x 6	9120	1,0 - 1,2 - 1,5 - 2,0	
	SINISTRO 45° <i>Left</i>	10 x 4 x 4	9123	0,5 - 0,6 - 0,7 - 0,8 - 0,9
		12 x 4 x 4	9124	
		15 x 4 x 4	9125	
		15 x 5 x 5	9127	1,0 - 1,2 - 1,5
		20 x 6 x 6	9128	0,5 - 0,6 - 0,7 - 0,8 - 0,9
		20 x 8 x 6	9129	
	20x10x 6	9130	1,0 - 1,2 - 1,5 - 2,0	
DESTRO 30° <i>Right</i>	15 x 4 x 4	9135	0,5 - 0,6 - 0,7 - 0,8 - 0,9	
	20 x 8 x 6	9139	1,0 - 1,2 - 1,5 - 2,0	
SINISTRO 30° <i>Left</i>	15 x 4 x 4	9145	0,5 - 0,6 - 0,7 - 0,8 - 0,9	
	20 x 8 x 6	9149	1,0 - 1,2 - 1,5 - 2,0	
	INCROCIATO 45° <i>Cross</i>	10 x 4 x 4	9153	0,5 - 0,6 - 0,7 - 0,8 - 0,9
		12 x 4 x 4	9154	
		15 x 4 x 4	9155	
		15 x 5 x 5	9157	1,0 - 1,2 - 1,5
		20 x 6 x 6	9158	0,5 - 0,6 - 0,7 - 0,8 - 0,9
		20 x 8 x 6	9159	
	20x10x 6	9160	1,0 - 1,2 - 1,5 - 2,0	
	INCROCIATO 30° <i>Cross</i>	15 x 4 x 4	9185	0,5 - 0,6 - 0,7 - 0,8 - 0,9
		20 x 8 x 6	9189	
		20x10x 6	9190	1,0 - 1,2 - 1,5 - 2,0

Tutte le versioni sono fornibili in **Metallo Duro**

All the types can be supplied in **Hard Metal**

INDICE DEI RICAMBI PER TORNI AUTOMATICI
INDEX OF SPARES FOR AUTOMATIC LATHES

BICCHIERI E GHIERE
SLEEVES AND NOSE CAPS

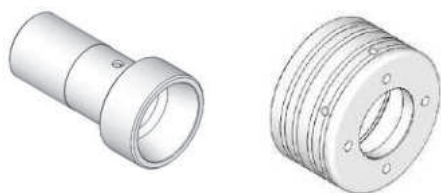

Pag.
371

SETTORI DI CHIUSURA PINZA
TWIN SECTORS FOR COLLET CLOSING

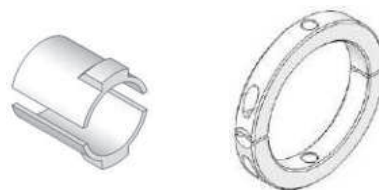

Pag.
375

MANICOTTI SCORREVOLI
CHUCK LEVER SLEEVES



Pag.
376

LEVETTE DI CHIUSURA PINZA
LEVERS FOR COLLET CLOSING

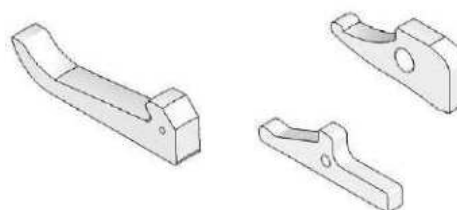

Pag.
377

MANDRINI PRINCIPALI
MAIN SPINDLES

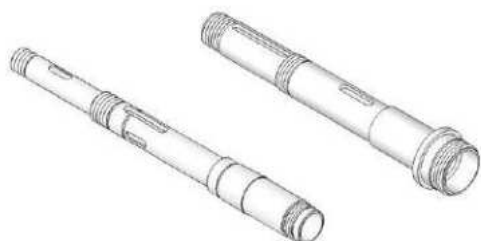

Pag.
379
409

SUPPORTI E CARRELLI
MOUNTINGS AND SLIDES

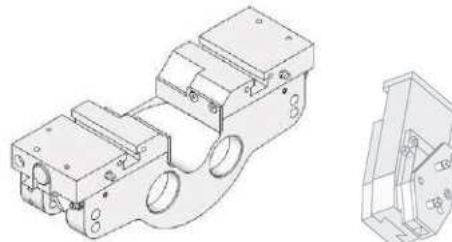

Pag.
380

CAMMES E PORTACAMMES
CAMS AND CAM HOLDERS



Pag.
386

CONTROPUNTE E CANOTTI
TAILSTOCKS AND SLEEVES

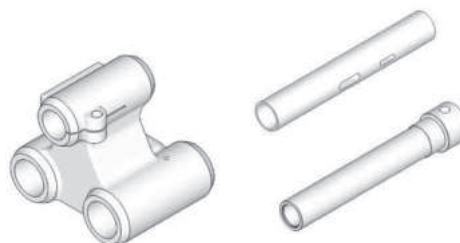

Pag.
398

INGRANAGGI
GEARS

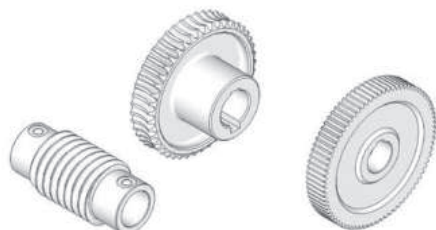

Pag.
403
406

BANDIERINE E CAPPOTTE
BAR PUSHERS AND COVERS

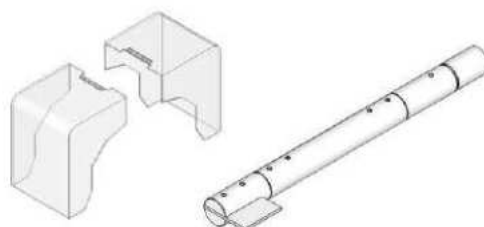

Pag.
407
408

BICCHIERI E GHIERE PER PINZE DOPPIO CONO
 SLEEVES AND NOSE CAPS FOR DOUBLE CONE COLLETS

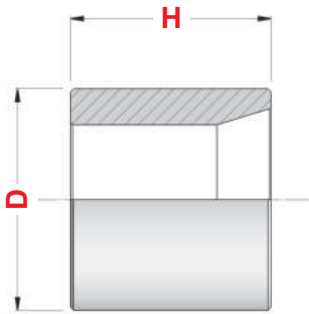

SEMICONO POSTERIORE
 REAR SEMICONE

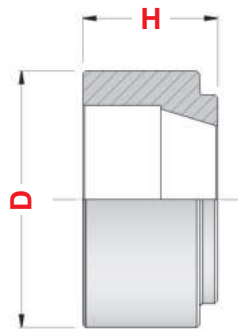

SEMICONO ANTERIORE
 HEAD SEMICONE

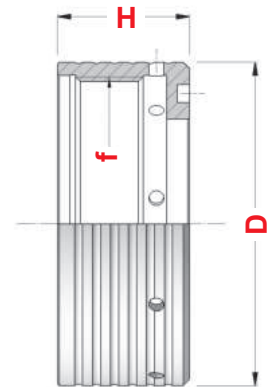

GHIERA
 NOSE CAP

R = Riduzione per altro modello di pinza
 Reduction for other kind of collet

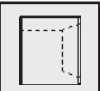
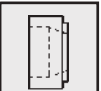
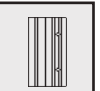
MACCHINA										
	Art.	D	H	Art.	D	H	Art.	D	H	f
GIORGI GM.25	1826 SP	37	38	1826 SA	50	37	1851 C	79	42	70 x 3 SX
GIORGI GM.32 (R)	1851 SP	44	39	1851 SA	56	42	1508 C	79	42	70 x 3 SX
TRAUB A.15	1772 SP	33	15	—	—	—	1772 C	52	45	43,5 x 2
TRAUB A.25	1791 SP	37	42	1791 SA	52	37	1791 C	72	39	62 x 2,5
TRAUB TD.26	1734 SP	40	40	1734 SA	54	28	1734 C	78	40	70 x 3
TRAUB A.42	1785 SP	54	58	1785 SA	68	38	1785 C	91	46	80 x 3
TRAUB TB.42	1785 SP	54	58	1785 SA	68	38	1785 C	91	46	80 x 3
TRAUB TK.42	1785 SP	54	58	1785 SA	68	38	1785 C	91	46	80 x 3
TRAUB A.60 (R)	1767 SP	74	67	1956 SA	86	45	1956 C	105	44,5	98 x 3
TRAUB TB.60 (R)	1956 SP	74	89	1956 SA	86	45	1956 C	105	44,5	98 x 3
UNAMUNO 25	1791 SP	37	42	1791 SA	52	37	1791 C	72	39	62 x 2,5



BICCHIERI E GHIERE PER PINZE CONO SEMPLICE

SLEEVES AND NUTS FOR SINGLE CONE COLLETS

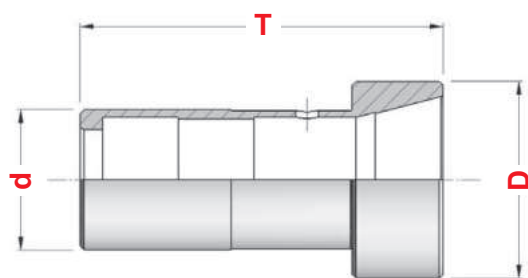

BICCHIERE
COLLET SLEEVE

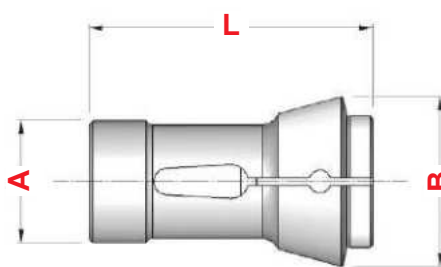

PINZA CONO SEMPLICE
SINGLE CONE COLLET

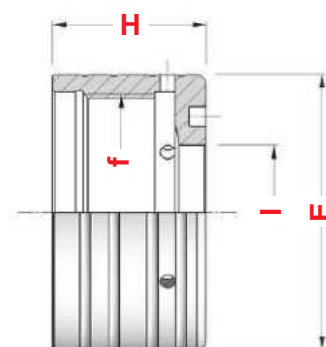

GHIERA
NOSE CAP

R = Riduzione per un altro modello di pinza
Reduction for other kind of collet

MACCHINA	Art.	d	D	T	Art.	Einheits	A	B	L	Art.	E	I	H	f
BECHLER A.10	1628	20	24	62	0740	117E	14	18	46	—	—	—	—	—
FEINLER FA.10	1752	20	24	86	0722	120E	15	21	64	0104	38	15,5	23	32 x 1,5
FEINLER FA.15	1751	27	32/37	61	0705	140E	22	30	55	1195	46	22,5	26	40 x 1,5
GIORGI GM.25	1745	37	50	92	0701	161E	32	45	75	1760	79	35	42	70 x 3 Sg N
GIORGI GM.30	2241	44	56	92,2	0764	163E	35	48	80	2247	79	39	42	70 x 3 Sg N
GIORGI GM.32	1493	44	56	92,2	0837	—	38	50,3	86	1508	79	42	42	70 x 3 Sg N
GIORGI GM.32 R	2616	44	56	92,2	0701	161E	32	45	75	1760	79	35	42	70 x 3 Sg N
INDEX 12	1133	28	38	68	0705	140E	22	30	55	2255	64,5	22	31,5	52 x 2 Sg N-SX
INDEX DG.12	1270	30	38	63,5	0671	143E	25	31	54	1271	62	24	23	52 x 2 Sg N-SX
INDEX DG.12 R	1272	30	38	63,5	0705	140E	22	30	55	1279	62	22	23	52 x 2 Sg N-SX
INDEX ON-OR.12	0348	30	32	64	0954	136E	20	26	54	2264	45	20	41	40 x 1,5 Sg N-SX
INDEX 18	1143	34	46	82	0713	148E	28	38	70	2256	68	29	31,5	58 x 2 Sg N-SX
INDEX C.19	1687	34	48	82	0713	148E	28	38	70	1695	73	29	34	63 x 2 Sg N-SX
INDEX 24	1177	42	58	92	0764	163E	35	48	80	1347	88	39	38,5	74 x 2 Sg N-SX
INDEX 25	1953	42	52	82	0615	162E	35	43	70	1659	72	35	31,5	63 x 2 Sg N-SX
INDEX 25 R	1954	42	52	82	0713	148E	28	38	70	2328	72	29	31,5	63 x 2 Sg N-SX
INDEX E.26 - ER.26	1177	42	58	92	0764	163E	35	48	80	1001	83	39	13	con FORI
INDEX C.29	1177	42	58	92	0764	163E	35	48	80	1306	84,5	39	35	74 x 2 Sg N-SX
INDEX B.30	1177	42	58	92	0764	163E	35	48	80	1479	88	39	38,5	74 x 2 Sg N-SX
INDEX 36 - B.42	1967	56	70	104	0709	173E	48	60	94	1239	97	51	38,5	85 x 2 Sg N-SX
INDEX 36 - B.42 R	1355	56	70	104	0764	163E	35	48	80	1356	97	39	38,5	85 x 2 Sg N-SX
INDEX E.42 - ER.42	1967	56	70	104	0709	173E	48	60	94	2597	102	51	30	85 x 2 Sg N-SX
INDEX E.42 - ER.42 R	1355	56	70	104	0764	163E	35	48	80	1930	102	39	30	85 x 2 Sg N-SX
INDEX 52	1267	74	94	108	0759	185E	66	84	110	1240	117	74,5	41,5	108 x 2 Sg N-SX
INDEX 52 R	1011	74	94	108	0709	173E	48	60	94	1021	117	51	41,5	108 x 2 Sg N-SX
INDEX B.60	1228	74	94	120	0759	185E	66	84	110	2682	122	74,5	34	108 x 2 Sg N-SX
INDEX B.60 R	2683	74	94	120	0709	173E	48	60	94	2684	122	51	34	108 x 2 Sg N-SX
INDEX E.60 - ER.60	1228	74	94	120	0759	185E	66	84	110	1185	136	74,5	16	con FORI
INDEX E.60 - ER.60 R	2683	74	94	120	0709	173E	48	60	94	1933	136	51	16	con FORI

➔ segue bicchieri e ghiera
continue sleeves and nuts

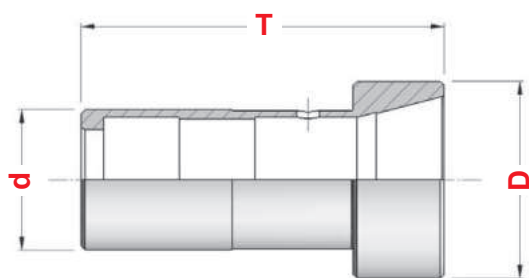

BICCHIERE
COLLET SLEEVE

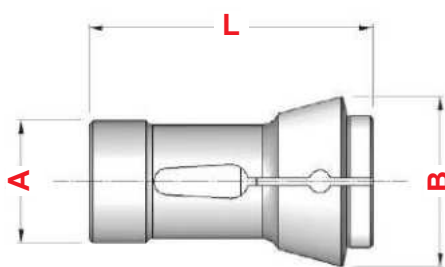

PINZA CONO SEMPLICE
SINGLE CONE COLLET

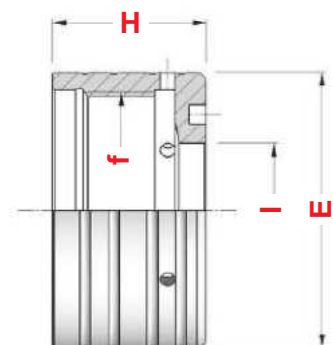

GHIERA
NOSE CAP

R = Riduzione per un altro modello di pinza
Reduction for other kind of collet



MACCHINA	Art.	d	D	T	Art.	Einheits	A	B	L	Art.	E	I	H	f
STROHM M.45	0411	12	15	66	0721	101E	8	12	42	—	—	—	—	—
STROHM 105 - 125	1752	20	24	86	0722	120E	15	21	64	0398	34	16	20	30 x 1,5 Sg N-SX
STROHM 205	1780	35	40	100	0717	145E	25	35	77	1631	63	28	40	56 x 1,5 Sg N-SX
STROHM 255	1740	38	45	110	0727	157E	30	42	80	2250	63	35	40	56 x 1,5 Sg N-SX
TORNOS M.4	0411	12	15	66	0721	101E	8	12	42	—	—	—	—	—
TORNOS R.10	2700	22	26	90	0722	120E	15	21	64	0290	37	16,5	17	33 x 1,25 SX
TORNOS ENC.164	1348	30	30	69	0954	136E	20	26	54	—	—	—	—	—
TRAUB A.15	1750	33	33	52	0705	140E	22	30	55	2244	53	22	45	44 x 2
TRAUB TC.15	1748	28	38	70	0705	140E	22	30	55	—	—	—	—	—
TRAUB TD.16	1937	28	40	70	0705	140E	22	30	55	—	—	—	—	—
TRAUB A.25	1755	37	52	96	0701	161E	32	45	75	1759	72	35	39	62 x 2,5
TRAUB A.25 R	1775	37	52	96	0705	140E	22	30	55	1776	72	22	39	62 x 2,5
TRAUB TD.26	0775	40	54	95	0701	161E	32	45	75	2378	78	35	40	70 x 3
TRAUB TD.36	2099	50	68	115	0861	171E	42	55	94	2085	86	43,5	40	80 x 3
TRAUB A.42	1743	54	68/75	114	0709	173E	48	60	94	1763	91	51	46	80 x 3
TRAUB A.42 R	1820	54	68/75	114	0701	161E	32	45	75	1821	91	35	46	80 x 3
TRAUB TB.42	1743	54	68/75	114	0709	173E	48	60	94	1763	91	51	46	80 x 3
TRAUB TB.42 R	1820	54	68/75	114	0701	161E	32	45	75	1821	91	35	46	80 x 3
TRAUB TG.42	1074	54	74	115	0709	173E	48	60	94	—	—	—	—	—
TRAUB TK.42	1743	54	68/75	114	0709	173E	48	60	94	1763	91	51	46	80 x 3
TRAUB TNS.42	1338	60	70	135	0709	173E	48	60	94	1339	130	51	23	con FORI
TRAUB A.60	1551	74	86/93	114	0759	185E	66	84	110	2248	105	74,5	44,5	98 x 3
TRAUB A.60 R	2246	74	86/93	114	0709	173E	48	60	94	2259	105	51	44,5	98 x 3
TRAUB TB.60	1196	74	86/93	138	0759	185E	66	84	110	2248	105	74,5	44,5	98 x 3
TRAUB TB.60 R	2258	74	86/93	138	0709	173E	48	60	94	2259	105	51	44,5	98 x 3
TRAUB TF.60	1881	82	95	138	0759	185E	66	84	110	1883	140	74,5	22	con FORI
TRAUB TNF.60	1884	75	95	138	0759	185E	66	84	110	1883	140	74,5	22	con FORI
UNAMUNO 15	1751	27	32/37	61	0705	140E	22	30	55	1195	46	22,5	26	40 x 1,5
UNAMUNO 25	1755	37	52	96	0701	161E	32	45	75	1759	72	35	39	62 x 2,5

MOLLE PER BICCHIERI PORTAPINZA

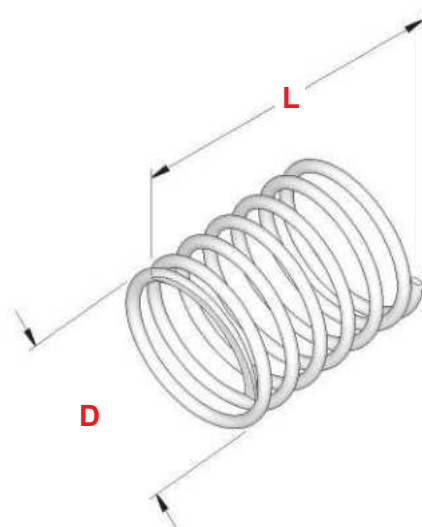
SPRINGS FOR COLLET SLEEVES



R = Riduzione per altro modello di pinza
Reduction for other kind of collet

MACCHINA						
	Art.	D	L	Art.	Art.	Einheits
FEINLER FA.10	1273	14,7	28	1752	0722	120E
FEINLER FA.15	5708	21,5	22	1751	0705	140E
GIORGI GM.25	1154	31,0	32	1745	0701	161E
GIORGI GM.30	1905	34,5	30	2241	0764	163E
GIORGI GM.32 R	1154	31,0	32	2616	0701	161E
INDEX 12	1359	21,5	31	1133	0705	140E
INDEX DG.12 R	5708	21,5	22	1272	0705	140E
INDEX ON-OR.12	2326	19,5	15	0348	0954	136E
INDEX 18	2507	27,5	22	1143	0713	148E
INDEX C.19	2507	27,5	22	1687	0713	148E
INDEX 24	1905	34,5	30	1177	0764	163E
INDEX 25	1905	34,5	30	1953	0615	162E
INDEX 25 R	2507	27,5	22	1954	0713	148E
INDEX E.26 - ER.26	1905	34,5	30	1177	0764	163E
INDEX C.29 - B.30	1905	34,5	30	1177	0764	163E
INDEX 36 - B.42 R	1905	34,5	30	1355	0764	163E
INDEX E.42 - ER.42 R	1905	34,5	30	1355	0764	163E
INDEX 52 R	2514	47,0	40	1011	0709	173E
INDEX B.60 - ER.60 R	2514	47,0	40	2683	0709	173E
STROHM 105 - 125	1273	14,7	28	1752	0722	120E
TORNOS R.10	1273	14,7	28	2700	0722	120E
TRAUB TC.15	1359	21,5	31	1748	0705	140E
TRAUB A.25	2510	31,0	37	1755	0701	161E
TRAUB A.25 R	5708	21,5	22	1775	0705	140E
TRAUB TD.26	2510	31,0	37	0775	0701	161E
TRAUB TD.36	2347	41,5	44	2099	0861	171E
TRAUB A.42	2514	47,0	40	1743	0709	173E
TRAUB A.42 R	2510	31,0	37	1820	0701	161E
TRAUB TB.42	2514	47,0	40	1743	0709	173E
TRAUB TB.42 R	2510	31,0	37	1820	0701	161E
TRAUB TK.42	2514	47,0	40	1743	0709	173E
TRAUB A.60 R	2514	47,0	40	2246	0709	173E
TRAUB TB.60 R	2514	47,0	40	2258	0709	173E
UNAMUNO 15	5708	21,5	22	1751	0705	140E
UNAMUNO 25	2510	31,0	37	1755	0701	161E

TUBI E DISTANZIALI PER CHIUSURA PINZA
TUBES AND SPACERS FOR COLLET CLOSING

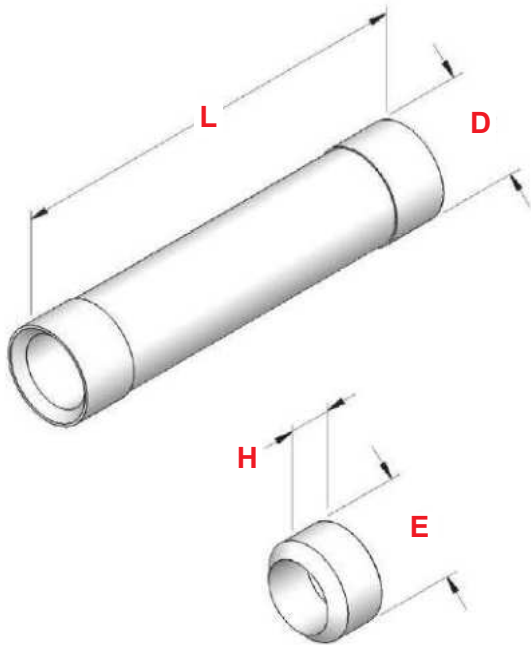

MACCHINA	Art.	D	L	Art.	E	H
GIORGI GM.20	2282	26,5	208	2301	26,5	29,5
GIORGI GM.32	1327	38,5	203	1506	38,5	26,5
STROHM 105	1636	16,8	73,5	1174	16,8	11
STROHM 125	2020	16,8	78	1175	16,8	10
TRAUB A.15 - TC.15	1353	21	156	1350	21	24
TRAUB A.15 - TC.15	1351	21	176	1350	21	24
TRAUB A.25	1483	32	132	1365	32	24
TRAUB A.25	1483	32	132	2314	32	26
TRAUB TD.26	2292	34	203	2315	34	15
TRAUB A.42	1882	51	230	2530	51	29
TRAUB TB.42	—	—	—	2531	51,8	25
TRAUB A.60	1534	70	234	2063	70	30
TRAUB TB.60	—	—	—	2063	70	30
UNAMUNO 15	0608	22	190	0083	22	19

SETTORI IN ACCIAIO PER CHIUSURA PINZA
STEEL TWIN SECTORS FOR COLLET CLOSING

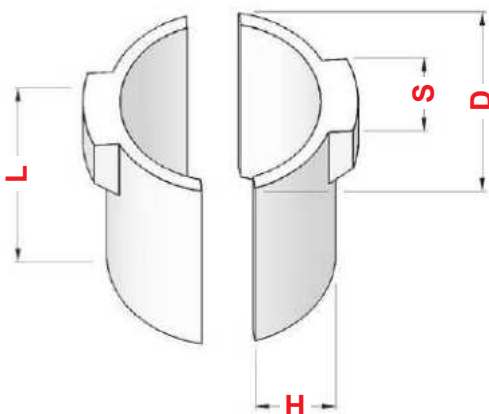

SETTORI IN BRONZO PER CHIUSURA PINZA
BRONZE TWIN SECTORS FOR COLLET CLOSING

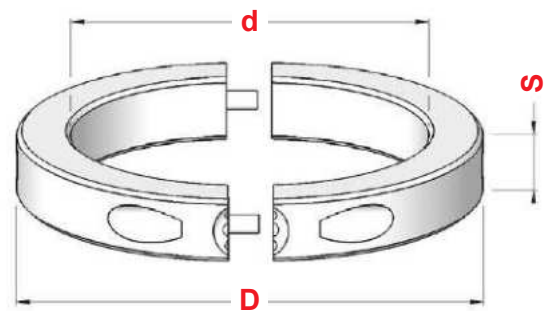

MACCHINA	Art.	D	L	S	H
INDEX DG.12	0303	24	36	11,6	8,0
INDEX 18 - C.19	2307	30	40	13,5	10,5
INDEX 25	1138	36	40	14,0	13,0
INDEX 24 - C.29 - B.30	1960	37	42	15,8	13,0
INDEX 36 - 42 - B.42	1108	48	52	19,5	18,4
INDEX 52 - 60 - B.60	2297	67	52	19,5	27,3

MACCHINA	Art.	D	d	S
INDEX 12 - 18 - C.19	2617	83	62,0	14
INDEX 25	2795	90	68,5	14
INDEX C.29	2675	93	72,0	14
INDEX 24 - 36 - 42	2643	118	92,0	18
INDEX B.30 - B.42	2643	118	92,0	18
INDEX 52 - 60 - B.60	0818	133	110,0	18

MANICOTTI SCORREVOLI
SLIDING SLEEVES AND OUTSIDE RINGS

MANICOTTI
CHUCK LEVER SLEEVES

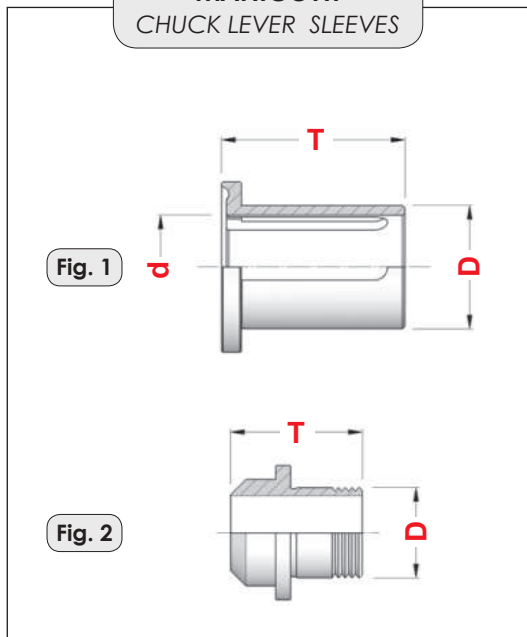

ANELLI ESTERNI
OUTSIDE RINGS

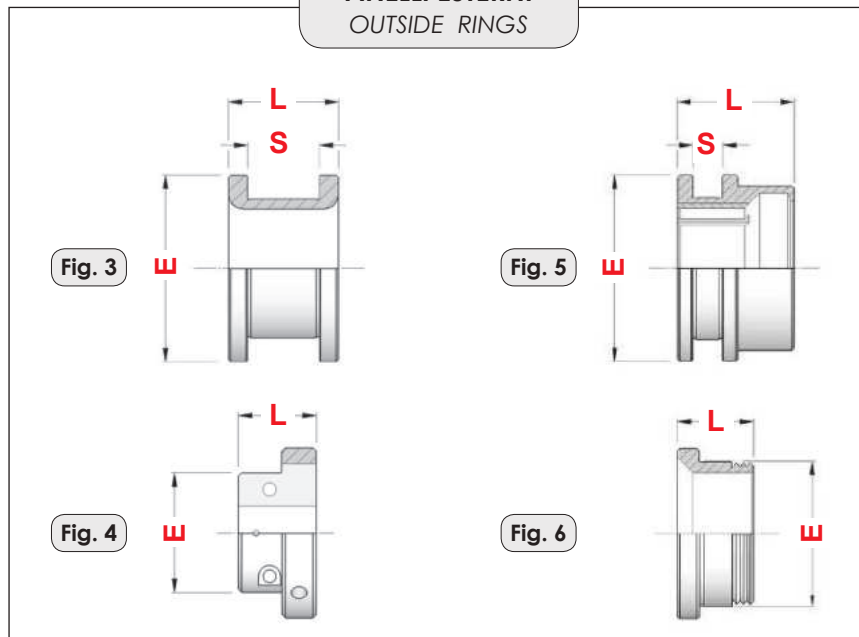

MACCHINA	MANICOTTI CHUCK LEVER SLEEVES					ANELLI ESTERNI OUTSIDE RINGS					LEVETTE di pag. 377 LEVERS page 377
	Art.	D	d	T	Fig.	Art.	E	L	S	Fig.	
FEINLER FA.15	1441	35	-	46	2	1406	59	45	-	4	n.2 pcs Art. 0850
GIORGI GM. 20	1726	47	35	85	1	2036	76	43	30	3	n.3 pcs Art. 0817
GIORGI GM. 32	1727	56	46	85	1	2038	91	43	30	3	n.3 pcs Art. 0817
INDEX 12	2031BI	44	34	72	1	2031AE	80	54	14	5	n.2 pcs Art. 0778
INDEX 18 - C.19	1733BI	50	39	72	1	1733AE	80	54	14	5	n.2 pcs Art. 0781
INDEX 24 - 29 - B.30	2518BI	68	48	94	1	2518AE	115	76	18	5	n.2 pcs Art. 0811
INDEX 25	2529BI	56	44	72	1	2529AE	86	54	14	5	n.2 pcs Art. 0781
INDEX C.29	5706BI	60	48	72	1	5706AE	90	54	14	5	n.2 pcs Art. 0782
INDEX 36 - 42	2474BI	80	59	94	1	2474AE	115	76	18	5	n.2 pcs Art. 0780
INDEX B.42	2474BI	80	59	94	1	2474AE	115	76	18	5	n.2 pcs Art. 0780
INDEX 52 - 60	0900BI	98	76	94	1	0900AE	128	55,5	18	5	n.2 pcs Art. 0780
INDEX B.60	0900BI	98	76	94	1	0900AE	128	55,5	18	5	n.2 pcs Art. 0780
STROHM 105 - 125	1440	30	-	44	2	2049	54	35	-	4	n.2 pcs Art. 0791
TRAUB A.15	1257BI	37	30	65,3	1	1257AE	57	40	22,5	3	n.2 pcs Art. 0795
TRAUB A.15	1321BI	42	30	72	1	1321AE	70	46	30,5	3	n.2 pcs Art. 0793
TRAUB A.15	0990BI	42	30	72	1	1321AE	70	46	30,5	3	n.2 pcs Art. 0776
TRAUB TC.15	0990BI	42	30	72	1	0990AE	50	43,5	-	6	n.2 pcs Art. 0776
TRAUB A.25	0991BI	50	42	75	1	0991AE	78	46	30,5	3	n.3 pcs Art. 0793
TRAUB A.25	1382BI	50	42	75	1	0991AE	78	46	30,5	3	n.3 pcs Art. 0776
TRAUB TB.25	1382BI	50	42	75	1	0991AE	78	46	30,5	3	n.3 pcs Art. 0776
TRAUB TC.25	1382BI	50	42	75	1	0991AE	78	46	30,5	3	n.3 pcs Art. 0776
TRAUB TD.26	5606BI	52	40	78	1	5606AE	60	45	-	6	n.3 pcs Art. 0974
TRAUB A.42	1019BI	79	60	76	1	1019AE	112	45	32,5	3	n.3 pcs Art. 0794
TRAUB TB.42	1741BI	80	65	90	1	1741AE	118	45	32,5	3	n.3 pcs Art. 0792
TRAUB TK.42	1741BI	80	65	90	1	1741AE	118	45	32,5	3	n.3 pcs Art. 0792
TRAUB A.60	1825BI	96	80	76	1	1301AE	128	45	32,5	3	n.3 pcs Art. 0794
TRAUB TB.60	1301BI	96	82	90	1	1301AE	128	45	32,5	3	n.3 pcs Art. 0792
UNAMUNO 15	1441	35	-	46	2	-	-	-	-	-	n.2 pcs Art. 0850
UNAMUNO 25	1091BI	55	47	78	1	1091AE	65	34	-	6	n.2 pcs Art. 0782

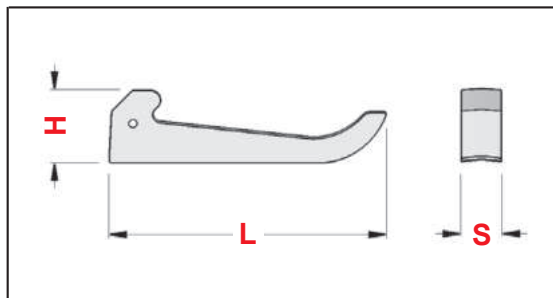

LEVETTE DI CHIUSURA PINZA
CHUCK LEVERS FOR COLLET CLOSING

MACCHINA	Art.	S	L	H	Foro	Figura
BECHLER A.7 - BR.10	0315	6	54,5	16	4	3
BECHLER BR.16 - 20	0314	12	76,2	28,6	6	4
BROWN & SHARPE 00	2296	12,5	61	15,5	-	2
CASER TA.26/30	0796	9,5	70	18	2	1
CASER TA.45/50	0814	14	92	27	-	2
CITIZEN G.16	2125	6	52	17,5	4	6
FEINLER FA.10/15	0850	7	50	19	6	6
GAUTIER GM.12	0311	6	57	15,5	4	3
GILDEMEISTER AS.16/20	2343	9	67,5	19,2	2,5	7
GILDEMEISTER AS.32	2382	24	73	24	-	8
GILDEMEISTER AS.32	2826	24	66	25	-	8
GILDEMEISTER AS.48	1249	30	74	25,7	-	8
GILDEMEISTER AS.48	2384	30	80	25,7	-	8
GIORGI GM.20/25/30/32	0817	10	74	22	6	5
INDEX 12	0778	11,8	74	20	-	2
INDEX ON - OR - DG.12	0185	11,8	66	17,2	-	2
INDEX 18 - C.19 - 25 - ER.25	0781	13,5	74	20	-	2
INDEX 24 - C.29	0782	15,5	74	20	-	2
INDEX 24 - C.29 - B.30	0811	15,5	100	24,2	-	2
INDEX E.25 IDRAULICA	2178	13,8	66	17,2	-	2
INDEX KS.32 - 42 - 50	2179	20	88	23	-	9
INDEX 36/52/60 - B.42/60	0780	19,8	100	24,2	-	2
ITS 26	0798	10	71	18	2	1
ITS 36 - 42 - 60	0975	17,5	88	28	8	10
MANURHIN PF - TR.22/25	0807	12	70,6	24	7	5
MUPEM TR.42	2708	20	112	34	10	5
SAIC B.26	0798	10	71	18	2	1
SAIC A.30/32	0797	14,5	73	24,5	6	5
SAIC B.30	0815	12	71	18	2	1
SCHAUBLIN 102/120HP	2298	13,5/12	62,2	19	-	11
STAR NC.16	2183	10	73	27	6	3
STAR KNC.32B	2184	12	50	25,5	8	6
STROHM 75-105-125	0791	7	50	21	6	6
STROHM 75-105-125-NAR	1800	7	50	21	8	6
TORNOS M.7	0182	7	58	18,3	5	3
TORNOS R.7 - R.10	0185	11,8	66	17,2	-	2
TORNOS NA.12	2390	9	55	21,3	6	3
TORNOS R.16	0781	13,5	74	20	-	2
TORNOS 20	2579	12	91	30	8	3
TRAUB A.15	0795	9	62	17	-	1
TRAUB A.15/20/25	0793	10	70	18	2	1
TRAUB TC.15 - A.15/25	0776	12	70	18	2	1
TRAUB TD.16/26/36	0974	12	74	18,3	2	9
TRAUB A.26/36/42/45/60	0794	14	70	20,7	2	1
TRAUB TB.30/42/60 - TK.42	0792	18	84	22	-	12
TSUGAMI S.20/BS.20/NP.20	2053	12	57	17	-	2
TSUGAMI S.20/BS.20/BE	2054	8	56	13	-	2
TSUGAMI NP.20	2055	12	85	22	-	2
TSUGAMI BS 32	2055	12	85	22	-	2
UNAMUNO 15	0850	7	50	19	6	6
UNAMUNO 25	0782	15,5	74	20	-	2

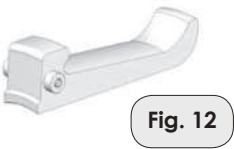
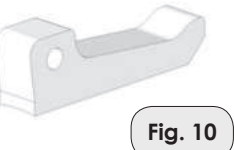
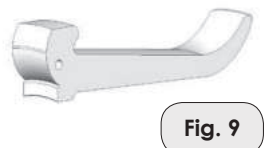
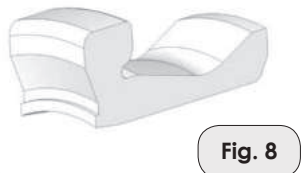
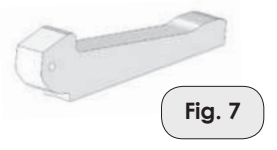
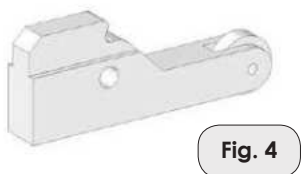
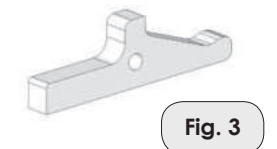

LEVETTE PER FRIZIONE INDEX
CLUTCH LEVERS FOR INDEX

LEVETTE PER FRIZIONE INDEX
CLUTCH LEVERS FOR INDEX

MACCHINA	Art.	A	F	H	L	S
INDEX 12-18-25-C19	0291	17	7	13,8	45	12
INDEX 24-E26-ER26	2721	20	8	15,8	50	14
INDEX C 29	0563	17	7	15,8	45	12
INDEX B30	2724	18	8	15,8	50	14
INDEX 36-52	2744	20	8	19,8	50	14
INDEX B42-60	2746	22	8	19,8	46	14

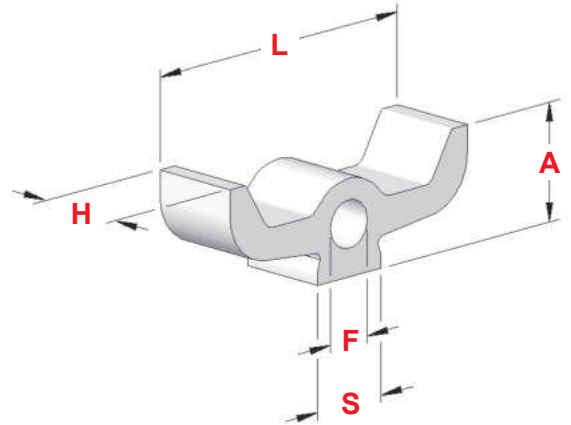

LEVETTE PER FRIZIONE CAMBIO VELOCITA' INDEX
LEVERS FOR INDEX GEAR SHIFT CLUTCH

MACCHINA	Art.	A	F	H	L	S
CAMBIO INDEX B30	2746	22	8	19,8	46	14
CAMBIO INDEX B42-60	2744	20	8	19,8	50	14

PIASTRINE PER FRIZIONE INDEX
CLUTCH PADS FOR INDEX

PIASTRINE PER FRIZIONE INDEX
CLUTCH PADS FOR INDEX

MACCHINA	Art.	A	F	H	L	S	Vite Art.
INDEX 12-18-25-C19	0269	6	5 x 0,5	14	39,5	12	2215
INDEX 24-E26-ER26	2705	8	5 x 0,5	16	45,5	16	2220
INDEX C 29	0564	6	5 x 0,5	16	39,5	12	2215
INDEX B30	2705	8	5 x 0,5	16	45,5	16	2220
INDEX 36-52	2745	8	5 x 0,5	20	45,5	16	2220
INDEX B42-60	2747	7	5 x 0,5	20	40,2	10	2281

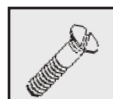

Vite Art.

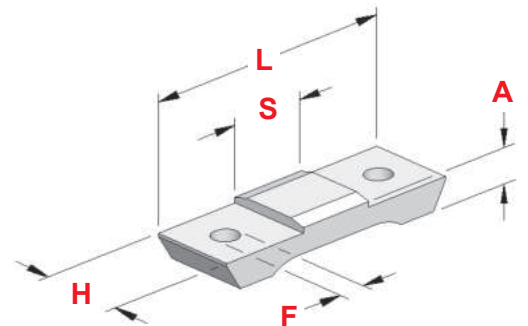

PIASTRINE PER FRIZIONE CAMBIO VELOCITA' INDEX
PADS FOR INDEX GEAR SHIFT CLUTCH

MACCHINA	Art.	A	F	H	L	S	Vite Art.
CAMBIO INDEX B30	2747	7	5 x 0,5	20	40,2	10	2281
CAMBIO INDEX B42-60	2745	8	5 x 0,5	20	45,5	16	2220



Vite Art.

MANDRINI PRINCIPALI TRAUB A 15 - A 25

MAIN SPINDLES FOR TRAUB A 15 - A 25

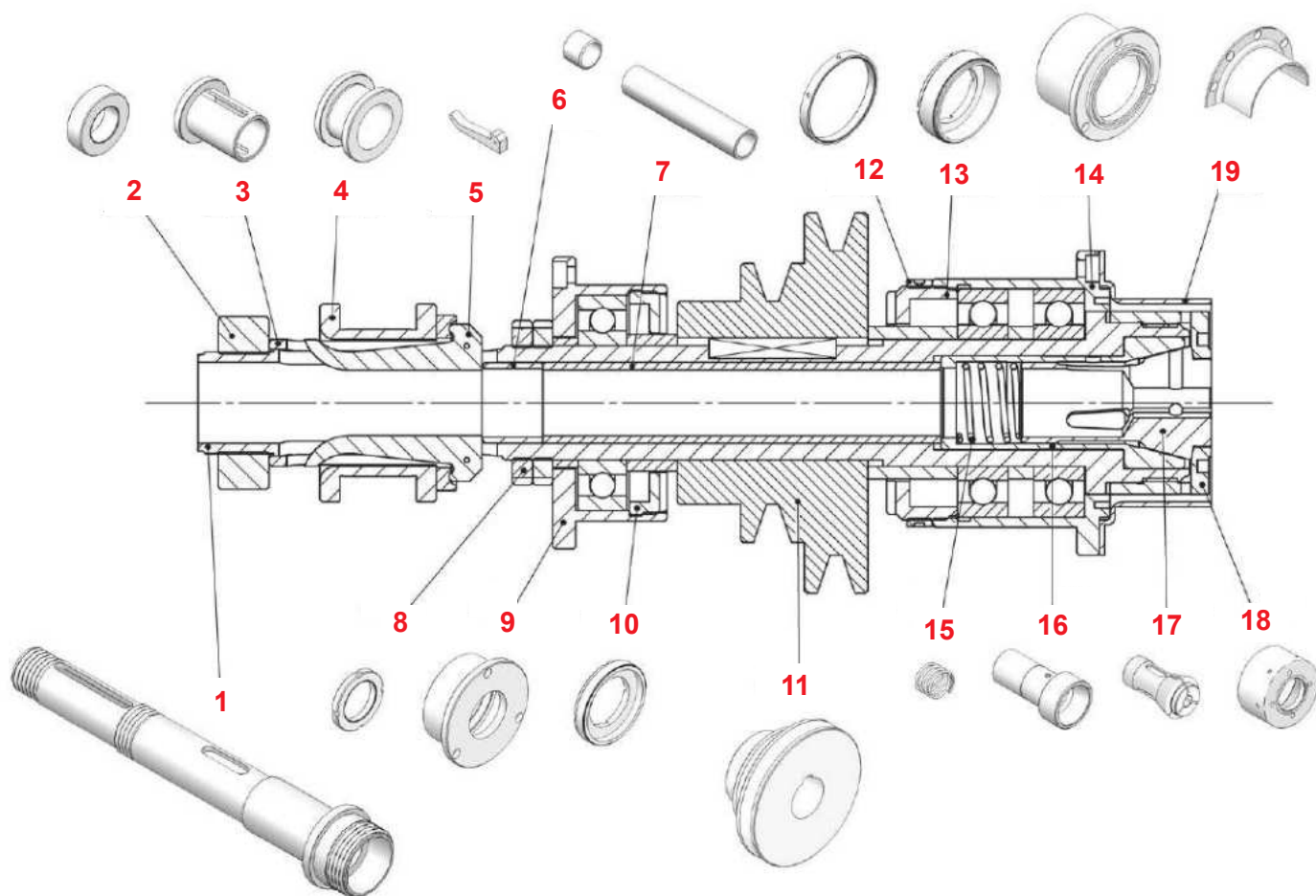

Pos.	COMPONENTI	TRAUB A.15		TRAUB A.25
		Art.	Art.	Art.
1	Mandrino Principale	1311	1332	2180
2	Ghiera Registro Manicotto	0857	0857	1998
3	Manicotto Porta Leve	1257 BI	1321 BI	1382 BI
4	Anello Scorrevole	1257 AE	1321 AE	0991 AE
5	Levette di chiusura	0795	0793	0776
6	Distanziale Compensatore	1350	1350	1365
7	Tubo Spingi Pinza	1351	1351	1483
8	Ghiera Registro Mandrino	1983	1983	1990
9	Alloggiamento Cuscinetti Posteriore	—	—	—
10	Ghiera Bloccaggio Cuscinetti - Post.	—	—	2266
11	Puleggia Velocità x Cinghia Sez. 13	1749	1749	1305
12	Controghiera Allogg. Cuscinetti Ant.	—	—	1349
13	Ghiera Bloccaggio Cuscinetti - Ant.	—	—	2275
14	Alloggiamento Cuscinetti Anteriore	—	—	2154
15	Molla per Bicchiere	—	—	2510
16	Bicchiere Porta Pinza	1750	1750	1755
17	Pinza di Serraggio	0705	0705	0701
18	Ghiera di Serraggio Pinza	2244	2244	1759
19	Paraspruzzi	—	—	—

SUPPORTO E CARRELLI VERTICALI TRAUB A 15 - A 20 - A 25

MOUNTING AND VERTICAL SLIDES FOR TRAUB A 15 - A 20 - A 25

FRONTE
FRONT VIEW

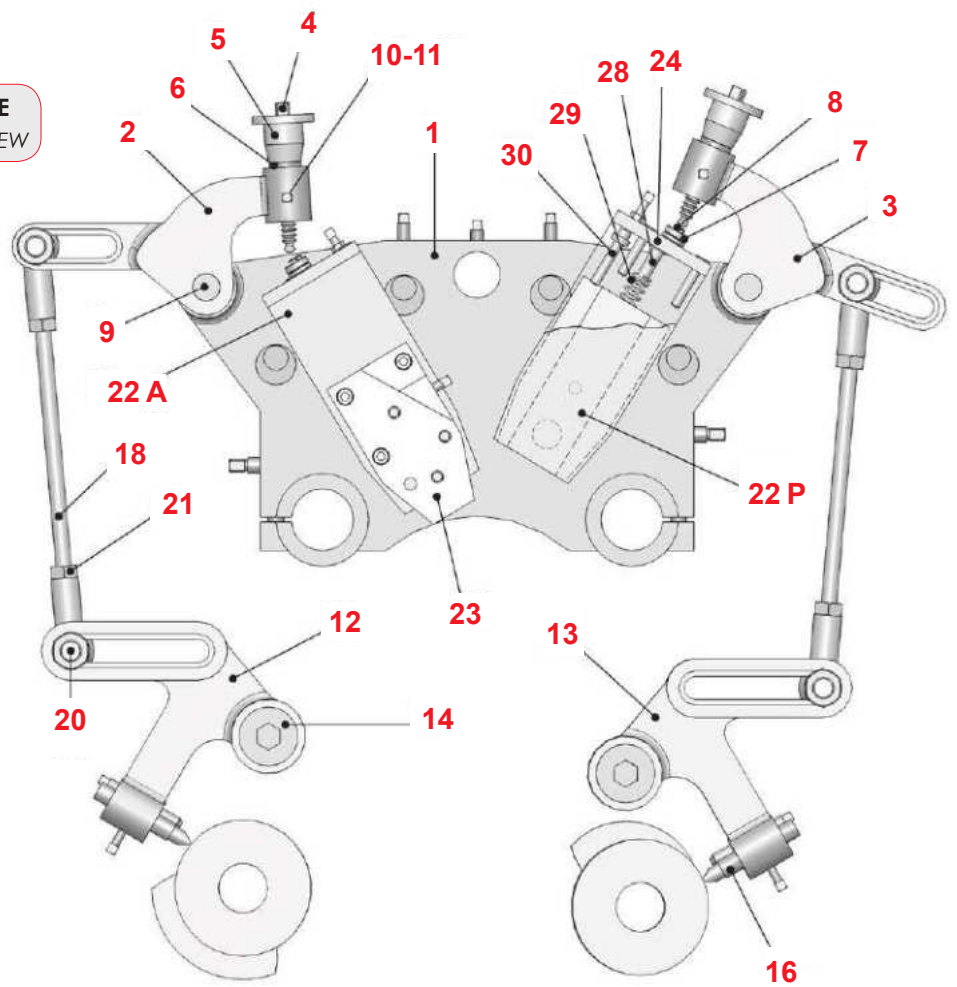

RETRO
REAR VIEW

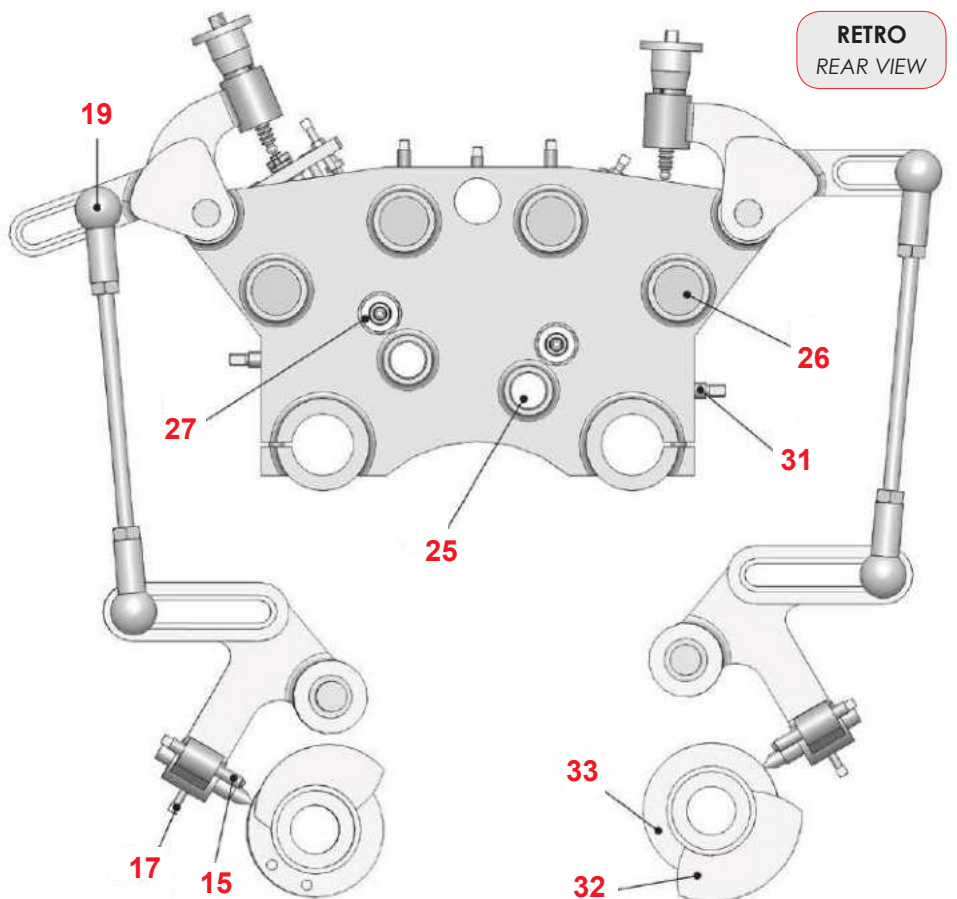

TRAUB A 15 - A 20 - A 25

Pos.	COMPONENTI	Art.
1	Supporto Carrelli	2166
2	Leva Superiore Ant.	1325
3	Leva Superiore Post.	—
4	Vite per Nonio	1973
5	Nonio Graduato	1578
6	Tamburo Graduato	1718
7	Pastiglia Spintore	1163
8	Molla per Pastiglia	0014
9	Spina Fulcro	0589
10	Vite Bloccaggio Nonio	2148 6x20
11	Pastiglia in Ottone	0123
12	Leva Inferiore Ant.	2160
13	Leva Inferiore Post.	2161
14	Perno Fulcro	1423
15	Vite Registro Leva	2148 7x60
16	Becco Camme	1244
17	Vite Bloccaggio Becchi	2148 6x20
18	Asta di Collegamento	2030
19	Sede Sferica	1624
20	Perno Sferico	1134
21	Dado di Registro	0105
22 A	Carrello Verticale Ant.	1475
22 P	Carrello Verticale Post.	1475
23	Portautensile	1456
24	Piastra di Pressione	1140
25	Perno di Attacco	1660
26	Perno di Registro	1661
27	Bussola di Registro Long.	2028
28	Perno per Molla	1136
29	Molla	0004
30	Vite Registro Lardone	1505
31	Vite Bloccaggio Carrello	2076
32	Camme	0659
33	Tamburo Porta Camme	1431

CARRELLI VERTICALI TRAUB TD 16 - TD26 - TD36

VERTICAL SLIDES FOR TRAUB TD16 - TD26 - TD36

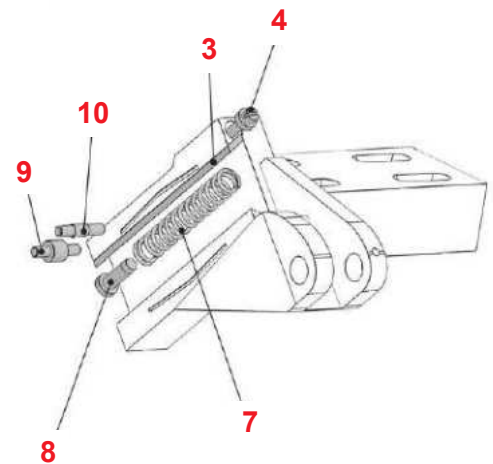
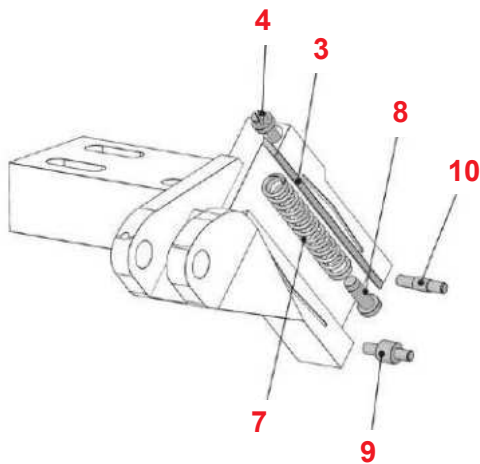
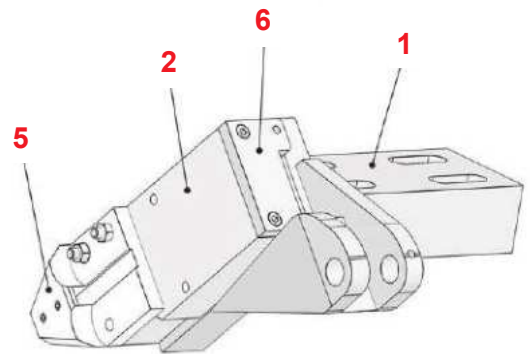
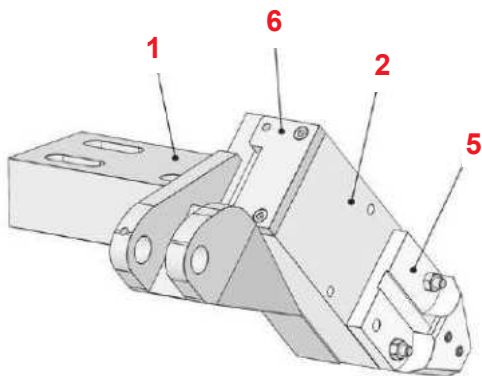

CARRELLO VERTICALE ANTERIORE

FORE VERTICAL SLIDE

CARRELLO VERTICALE POSTERIORE

REAR VERTICAL SLIDE

		TRAUB TD.16 - 26 - 36
Pos.	COMPONENTI	Art.
1	Slitta Femmina	2109
2	Slitta Maschio	
3	Lardone con Vite di Registro	
4	Vite Registro Lardone	1505
5	Porta Utensile	2755
6	Piastrina per Molla	2318
7	Molla	2332
8	Perno Guidamolla	2333
9	Perno Fulcro Porta Utensile	2334
10	Perno Fissaggio Porta Utensile	2357

		TRAUB TD.16 - 26 - 36
Pos.	COMPONENTI	Art.
1	Slitta Femmina	2209
2	Slitta Maschio	
3	Lardone con Vite di Registro	
4	Vite Registro Lardone	1505
5	Porta Utensile	2755
6	Piastrina per Molla	2385
7	Molla	2332
8	Perno Guidamolla	2333
9	Perno Fulcro Porta Utensile	2334
10	Perno Fissaggio Porta Utensile	2357

CARRELLI TRASVERSALI ORIZZONTALI TRAUB A15 - A20 - A25

CROSSWISE HORIZONTAL SLIDERS FOR TRAUB A15 - A20 - A25

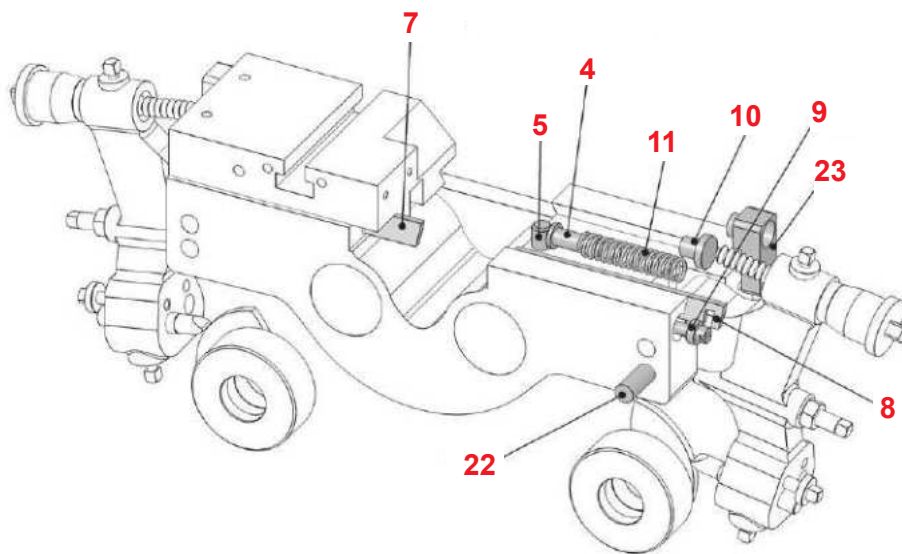
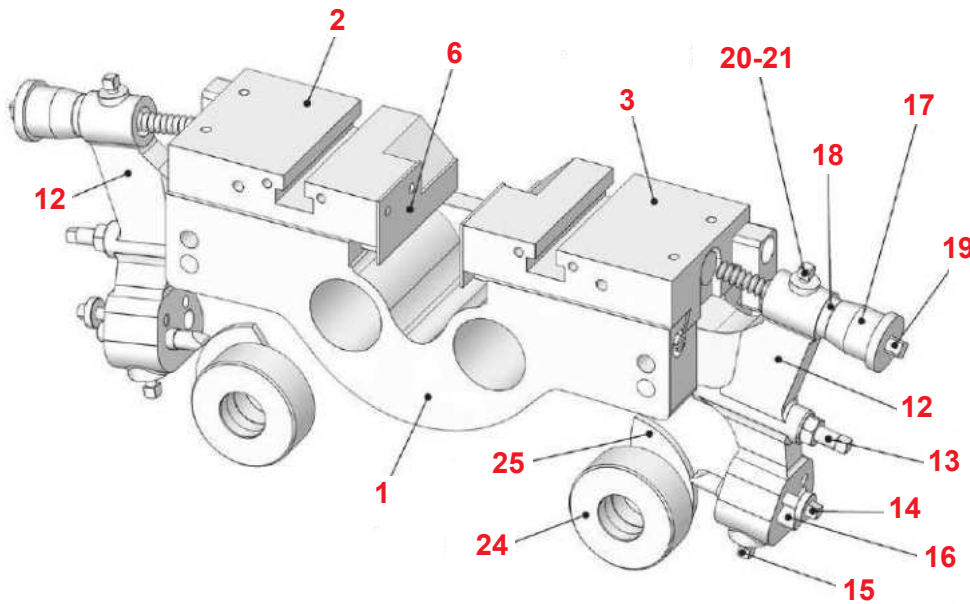

TRAUB A15 - A20 - A25

Pos.	COMPONENTI	Art.
1	Supporto Slitte	—
2	Slitta Anteriore	—
3	Slitta Posteriore	—
4	Perno Guida Molla	0236
5	Perno Battuta Molla	1099
6	Lamierino di Protezione	1122
7	Lardone Anteriore	—
8	Lardone Posteriore	—
9	Vite Registro Lardone	1505
10	Perno di Arresto	1142
11	Molla	0004
12	Leva d.10	1845
13	Vite di Registro Leva	2148 7x70
14	Vite di Registro Tastatori	1255
15	Vite di Bloccaggio Tastatori	2148 7x30
16	Tastatore Camme	1244
17	Nonio Foro d. 7 / Hole d. 7	0475
	Nonio Foro d.10 / Hole d.10	1578
18	Indice Foro d. 7 / Hole d. 7	0489
	Indice Foro d.10 / Hole d.10	1718
19	Vite per Nonio M7x1	0476
	Vite per Nonio M10x1	1171
20	Vite di Bloccaggio Nonio	2148 6x20
21	Pastiglia in Ottone d.5	0123
22	Spina Fulcro per Leva	1156
23	Arresto Per Slitte	1580
24	Porta Camme	1430
25	Camme	0658

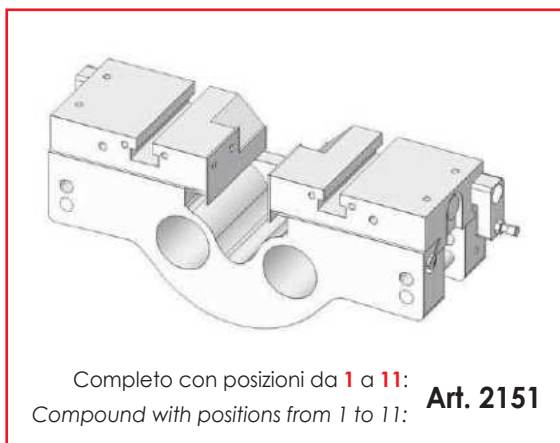

Completo con posizioni da 1 a 11:
Compound with positions from 1 to 11: **Art. 2151**

CARRELLI TORNITURA LONGITUDINALE TRAUB

LONGITUDINAL TURNING SLIDERS FOR TRAUB

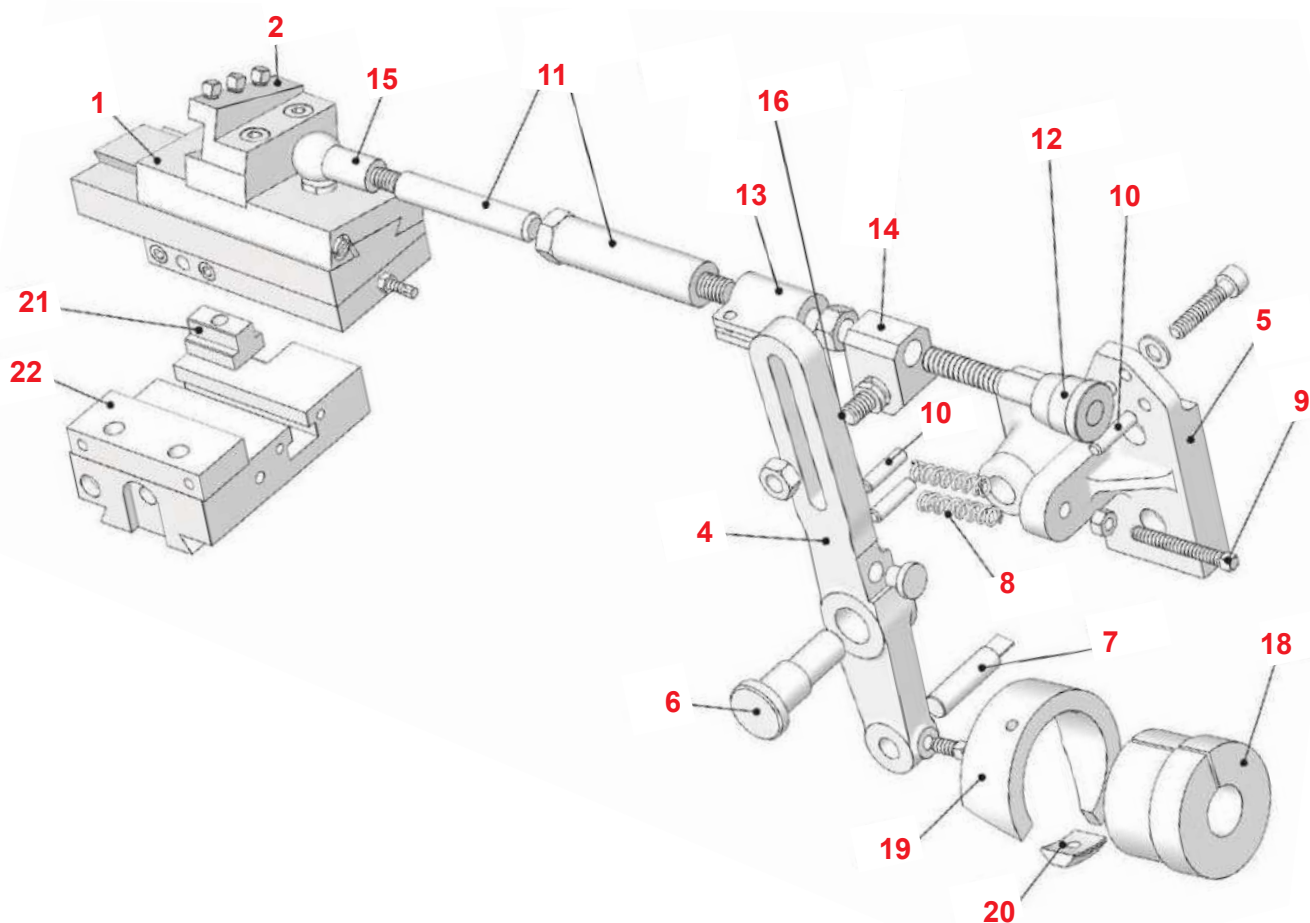

Pos.	COMPONENTI	TRAUB	TRAUB
		A.15 - 20 - 25	TB.30 - 42 - 60
1	Carrello Tornitura Longitudinale	1495	2143
2	Porta Utensile	1457	2102
4	Leva Tornitura Longitudinale	1822	2142
5	Supporto Leva	—	2141
6	Perno di Fissaggio	1179	0532
7	Tastatore con Rullo	0293	0551
	Tastatore a Penna (in alternativa al Tastatore con Rullo)	0224	—
8	Molla di Ritorno	0010	0524
9	Vite di Registro	2148 7x60	—
10	Perno Tendi Molla	0540	—
11	Asta con Registro d. 10	1530	—
12	Nonio Graduato Foro d. 10 / Hole d. 10	1578	—
13	Morsetto per Asta con Registro	1625	—
14	Supporto Sferico per Asta con Registro	1619	—
15	Sede Sferica per Asta con Registro	1624	—
16	Perno Sferico per Asta con Registro	1134	—
18	Porta Camme	1432	2164
19	Camme	0661	0664
20	Tassello Curvo	—	1148
21	Tassello di Bloccaggio	1548	—
22	Registro Carrello	0464	—

NONI, INDICI E VITI MICROMETRICHE PER CARRI VERTICALI
 VERNIERS, INDEXES AND ADJUSTING SCREWS FOR VERTICAL SLIDES

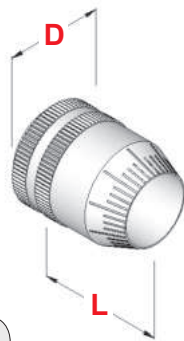



Nonio
Vernier

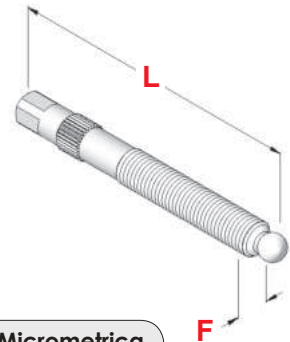

Indice
Index



Vite Micrometrica
Adjusting Screw

MACCHINA									
	Art.	D	L	Art.	D	d	Art.	F	L
SAIC B.26 - 30	—	—	—	—	—	—	2048	8 x 1	91
TRAUB A.15 - 20 - 25	1578	31	29	1718	21	15	1973	10 x 1	87
TRAUB A.36 - 42 - 60	1578	31	29	1718	21	15	1973	10 x 1	87
TRAUB TB.30 - 42 - 60	1578	31	29	—	—	—	—	—	—

NONI, INDICI E VITI MICROMETRICHE PER CARRI TRASVERSALI
 VERNIERS, INDEXES AND ADJUSTING SCREWS FOR CROSSWISE SLIDES

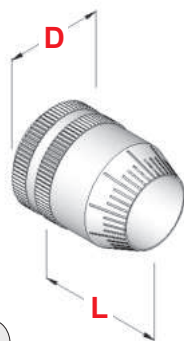





Nonio
Vernier

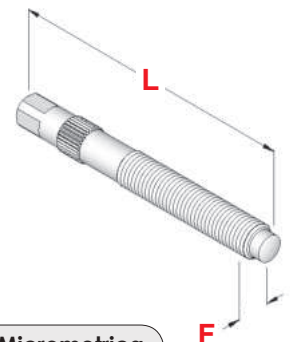

Indice
Index



Vite Micrometrica
Adjusting Screw

MACCHINA										
	Art.	D	L	Art.	D	d	Art.	F	L	Art.
TRAUB A.15 - 20 - 25	1578	31	29	1718	21	15	1171	10 x 1	87	—
TRAUB A.36 - 42 - 60	1578	31	29	1718	21	15	1171	10 x 1	87	—
TRAUB TB.30 - 42 - 60	2077	74	28	—	—	—	0625	tr. 25 x 3	121	0118

MOLLE PREMENTI
PUSHING SPRINGS

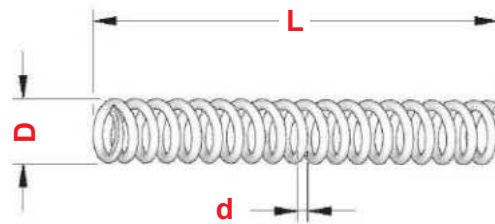

MACCHINA	Posizione - Position	Art.	D	L	d
GIORGI GM 20 - 25 - 32	Carri Verticali / Carri Orizzontali	1856	12,5	100	1,8
TRAUB A.15 - 20 - 25	Carri Verticali / Carri Orizzontali	0004	13,0	100	2,0
	Ritorno Canotti (App. Fora Filetti)	0001	10,0	176	1,5
	Ritorno Alberino (App. Fora Filetti)	1928	14,0	121	1,5
	Disco Frizione	1080	17,0	35	1,0
	Disco Frizione	0032	7,0	50	1,0
TRAUB TD.16 - 26 - 36	Carri Verticali	2332	15,0	215	2,0
	Carri Orizzontali	1975	11,5	155	1,6
TRAUB A.36 - 42 - 60	Carri Orizzontali	0165	14,0	120	2,2
	Carri Verticali	0002	13,0	155	2,0
	Disco Frizione	0419	10,0	60	1,5
TRAUB TB.30 - 42 - 60	Carri Verticali / Carri Orizzontali	0005	15,0	195	2,0
	Fermo Barra Verticale	2607	36,0	130	2,5
	Carri Tornitura Longitudinale	0524	14,0	327	2,0

MOLLE A TRAZIONE
PULLING SPRINGS

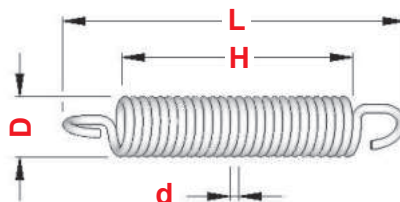

MACCHINA	Posizione - Position	Art.	D	L	H	d
TRAUB A.15 - 20 - 25	Fermo Barra	0012	13	58	32	1,5
	Leva Tornitura Longitudinale	0010	15	58	34	2,0
	Ribaltamento (App. Fora Filetti)	0028	10	73	53	1,5
TRAUB A.36 - 42 - 60	Fermo Barra	0027	15	71	45	2,0
	Leva Tornitura Longitudinale	0298	16	129	97	2,2
TRAUB TB.30 - 42 - 60	Fermo Barra Verticale	2655	20	129	89	3,0

PORTA CAMME AD ANELLO
RING CAMS HOLDERS

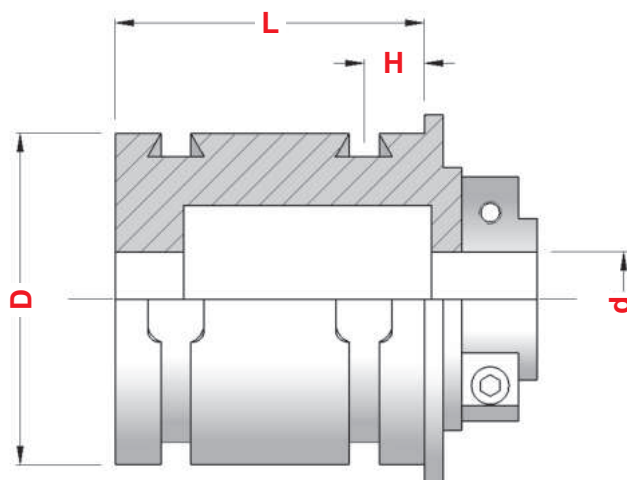



Fig. 1

Per CONTROPUNTA For Tailstock								
MACCHINA	Art.	Fig.	D	d	L	H	Art.	
TRAUB A.15 - 20 - 25	1979	1	95	25	93	15	0660	
TRAUB TD.16 - 26 - 36	1995	1	110	30	132	12,5	—	
TRAUB A.36 - 42 - 60	2144	1	125	40	158	20	0664	
TRAUB TB.30 - 42 - 60	2164	1	125	35	158	20	0664	

Per APPARECCHIO FORO-FILETTO For Drill - Thread Device								
MACCHINA	Art.	Fig.	D	d	L	H	Art.	
TRAUB A.15 - 20 - 25	1979	1	95	25	93	15	1555	

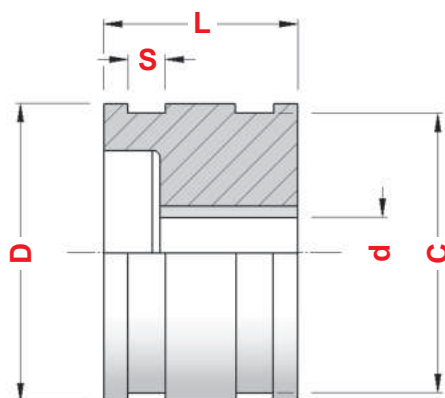





Fig. 2

Per APERTURA - CHIUSURA PINZA For Open - Close Collet											
MACCHINA	Art.	Fig.	D	d	L	C	S	Art.	Art.	Art.	
TRAUB A.15 - 20 - 25	1832	2	80	20	52	74	10	0636	0637	0638	
TRAUB TD.16 - 26 - 36	2157	2	115	30	73	110	54	—	—	—	
TRAUB A.36 - 42 - 60	2168	2	120	28	72	110	15	2394	2395	2396	
TRAUB TB.30 - 42 - 60	2176	2	140	30	92	130	15	1443	1444	1445	

➔ segue porta camme ad anello
continue ring cams holders

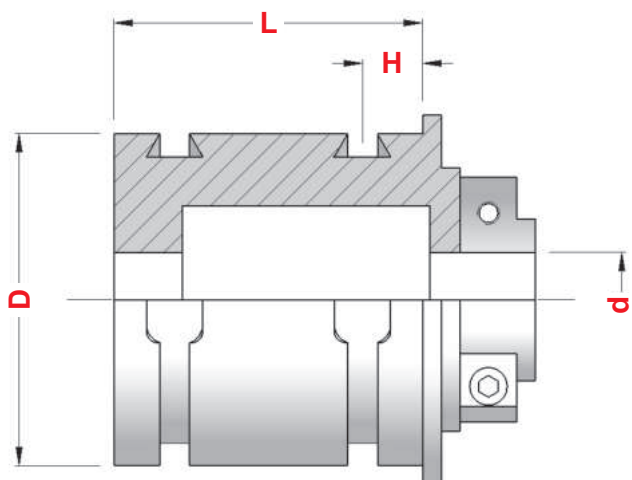

Fig. 1

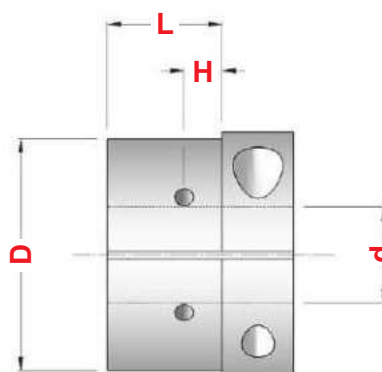

Fig. 4

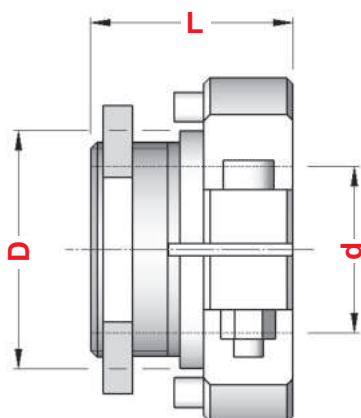

Fig. 5

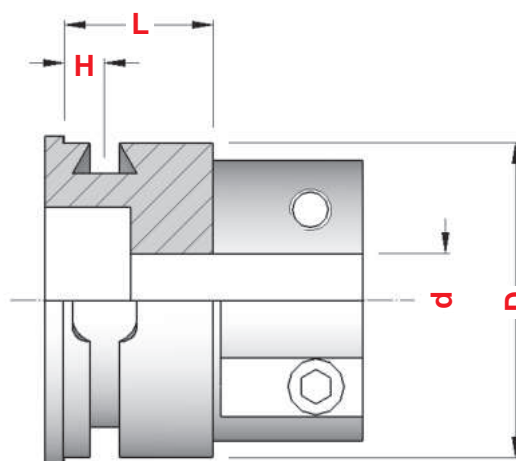



Fig. 6

Per TORNITURA LONGITUDINALE For Longitudinal Turning							
MACCHINA	Art.	Fig.	D	d	L	H	
GIORGI GM.20-25-32	1432	4	60	25	25	10	0661
TRAUB A.15-20-25	1432	4	60	25	25	10	0661
TRAUB TD.16-26-36	1463	5	40	30	-	-	-
TRAUB A.36-42-60	2152	6	95	32	100	15	0665
TRAUB TB.30-42-60	2164	1	125	35	158	20	0664

TASSELLI DI BLOCCAGGIO PER CAMME AD ANELLO

RING CAMS LOCKING DOWELS

Fig. 1

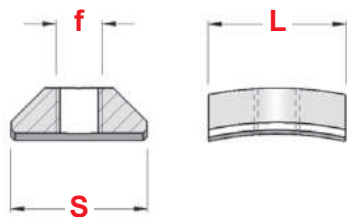
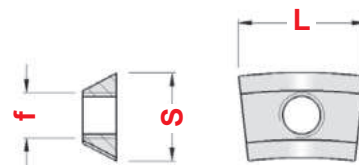

Fig. 2



MACCHINA	CAMME	Art.	f	S	L	Figura
GIORGI GM.20 - 25 - 32	Contropunta	2576	M 6	15	22	1
GIORGI GM.20 - 25 - 32	Foro Filetto	1137	M 6	19	20	1
STROHM 75 - 105 - 125	Apparecchio 3 Mandrini	1145	M 6	11,2	14	1
STROHM 75 - 105 - 125	Carri Verticali	1146	M 6	11,5	15	2
TRAUB A.15 - 20 - 25	Contropunta - Foro Filetto	1147	M 6	18	18	1
TRAUB TD.16 - 26 - 36	Contropunta	1147	M 6	18	18	1
TRAUB A.36 - 42 - 60	Contropunta - Torretta	1148	M 8	20	24	1
TRAUB TB.30 - 42 - 60	Contropunta - Torretta	1148	M 8	20	24	1

CAMME AD ANELLO PER APERTURA e CHIUSURA PINZA

RING CAMS FOR OPENING-CLOSING COLLET

MACCHINA	Art.	H	I	Figura
GIORGI GM. 20 - 25 - 30 - 32	0636	24	11	1
TRAUB A.15 - 20 - 25	0636	24	11	1
TRAUB A.36 - 42 - 60	2394	32	12,5	1
TRAUB TB.30 - 42 - 60	1443	42,5	12,5	1

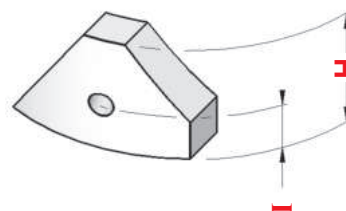

Camma Contro
Counter Cam
Fig. 1

MACCHINA	Art.	H	I	Figura
GIORGI GM. 20 - 25 - 30 - 32	0637	29	11	2
TRAUB A.15 - 20 - 25	0637	29	11	2
TRAUB A.36 - 42 - 60	2395	39	12,5	2
TRAUB TB.30 - 42 - 60	1444	47	12,5	2

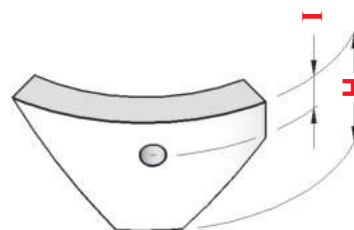

Camma Apertura
Opening Cam
Fig. 2

MACCHINA	Art.	H	I	Figura
GIORGI GM. 20 - 25 - 30 - 32	0638	32	11	3
TRAUB A.15 - 20 - 25	0638	32	11	3
TRAUB A.36 - 42 - 60	2396	35	12,5	3
TRAUB TB.30 - 42 - 60	1445	49	12,5	3

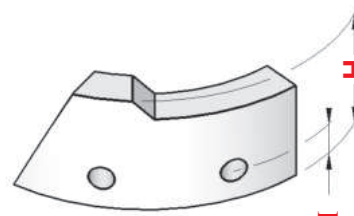

Camma Chiusura
Closing Cam
Fig. 3

CAMME AD ANELLO PER CONTROPUNTA A FORARE

RING CAMS FOR BORE TAILSTOCK

MACCHINA	Art.	D	d	I
GIORGI GM. 20 - 25 - 30 - 32	0503	108	88	15
TRAUB A.15 - 20 - 25	0660	115	95	15
TRAUB A.36 - 42 - 60	0664	150	125	20
TRAUB TB.30 - 42 - 60	0664	150	125	20

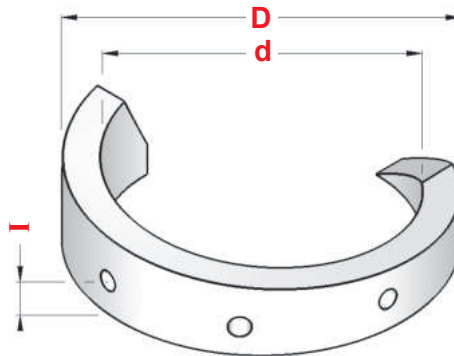

Al momento dell'ordine specificare **GRADI** e **CORSA**

At the moment of the order specify **DEGREES** and **STROKE**

CAMME AD ANELLO PER RITORNO CONTROPUNTA

RING CAMS FOR TAILSTOCK RETURN

MACCHINA	Art.	Gradi	H	I
GIORGI GM. 20 - 25 - 30 - 32	0507	56°	62	20
TRAUB A.15 - 20 - 25	0511	60°	70	20
TRAUB A.36 - 42 - 60	0512	90°	125	20
TRAUB TD.16 - 26 - 36	0685	90°	112	20

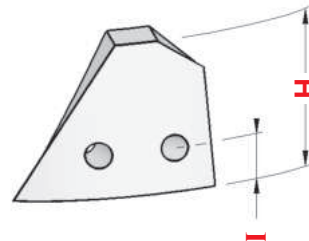

CAMME AD ANELLO PER TORNITURA LONGITUDINALE

RING CAMS FOR LONGITUDINAL TURNING

MACCHINA	Art.	D	d	I
GIORGI GM. 20 - 25 - 30 - 32	0661	80	60	10
TRAUB A.15 - 20 - 25	0661	80	60	10
TRAUB A.36 - 42 - 60	0665	115	95	15
TRAUB TB.30 - 42 - 60	0664	150	125	20

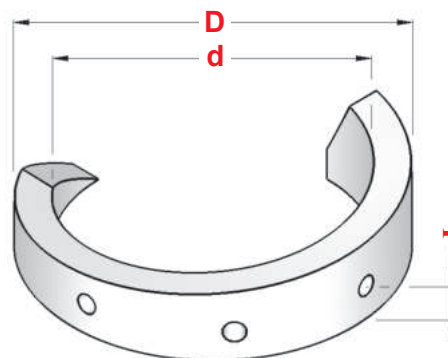

Al momento dell'ordine specificare **GRADI** e **CORSA**

At the moment of the order specify **DEGREES** and **STROKE**

CAMME AD ANELLO PER RITORNO TORNITURA LONGITUDINALE

RING CAMS FOR LONGITUDINAL TURNING RETURN

MACCHINA	Art.	Gradi	H	I
GIORGI GM. 20 - 25 - 30 - 32	0505	50°	49	10
TRAUB A.15 - 20 - 25	0505	50°	49	10

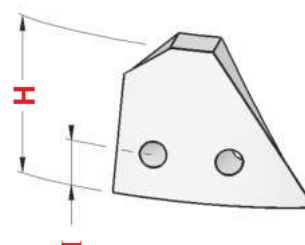

PORTA CAMME A DISCO
DISK CAMS HOLDERS

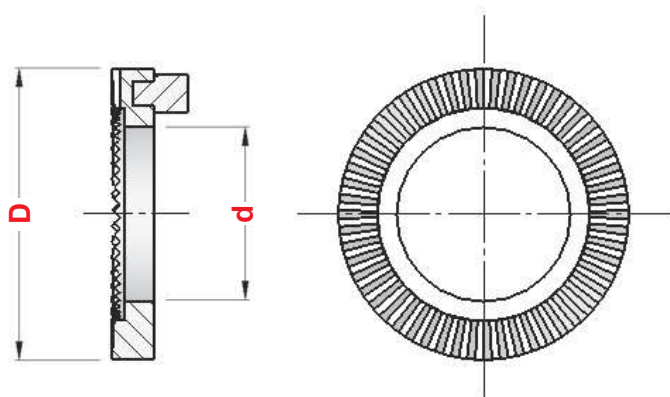

Fig. 1

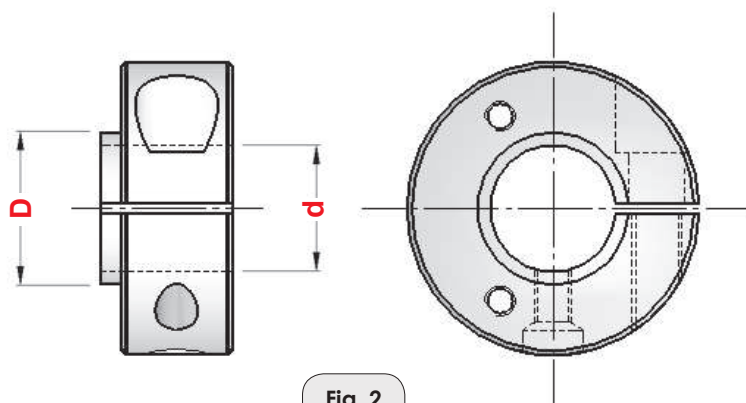

Fig. 2

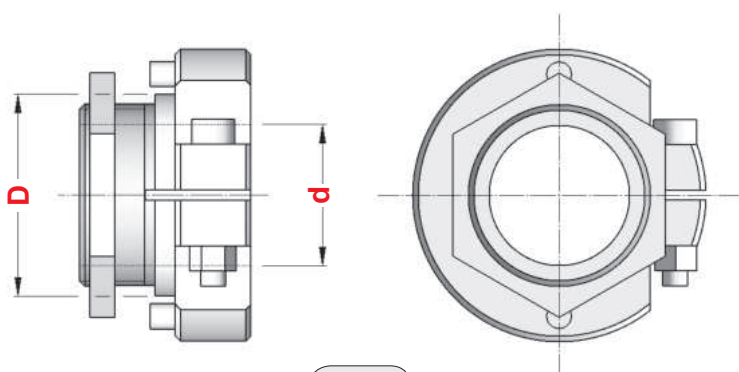





Fig. 3

MACCHINA	CARRI	Art.	D	d	Figura	 Art.	 Art.	 Art.	 Art.
INDEX DG.12	Trasversali	1893	50	30	1	—	—	—	—
INDEX 12 - 18 - 25	Trasversali	1897	56	32	1	—	—	—	—
INDEX 12 - 18 - 25	Verticali	1898	66	42	1	—	—	—	—
INDEX C.19 - C.29	Trasversali - Verticali	3182	60	36	1	—	—	—	—
INDEX 24 - 36 - 42 - 52 - 60	Trasversali	2936	68	40	1	—	—	—	—
INDEX B.42 - 60	Trasversali - Verticali	2936	68	40	1	—	—	—	—
TRAUB A.15 - 20 - 25	Trasversali	1430	30	25	2	0658	—	—	—
TRAUB A.15 - 20 - 25	Fermo Barra	1430	30	25	2	—	0516	—	—
TRAUB A.15 - 20 - 25	Verticali	1431	45	25	2	0659	—	—	—
TRAUB A.15 - 20 - 25	Ribaltamento Foro- Filetto	1547	36	25	2	—	—	0514	0515
TRAUB TD.16 - 26 - 36	Trasversali - Verticali	1463	40	30	3	—	—	—	—
TRAUB A.36 - 42 - 60	Trasversali - Fermo Barra	1345	40	32	2	0662	0517	—	—
TRAUB A.36 - 42 - 60	Verticali	1346	58	32	2	0663	—	—	—
TRAUB TB.30 - 42 - 60	Trasversali - Verticali	2444	45	35	2	0657	—	—	—

CAMME A DISCO PER FERMO BARRA

DISK CAMS FOR BAR STOP

MACCHINA	Art.	Gradi	R	d	Figura
GIORGI GM. 20 - 25 - 30 - 32	1130	46°	36	30	1
TRAUB A.15 - 20 - 25	0516	46°	36	30	1
TRAUB A.36 - 42 - 60	0517	42°	47	40	1
TRAUB TB.30 - 42 - 60	0596	48°	80	45	2

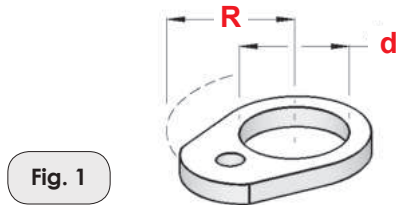

Fig. 1

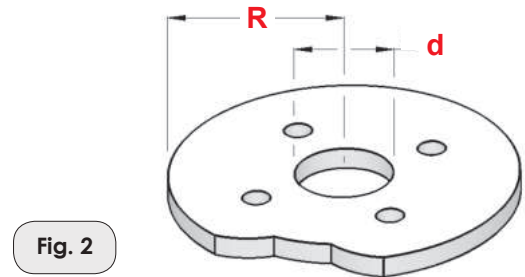

Fig. 2

CAMME A DISCO PER CARRI TRASVERSALI E VERTICALI

DISK CAMS FOR CROSSWISE AND VERTICAL SLIDES

MACCHINA	CARRI	Art.	D	d	S
GIORGI GM. 20 - 25	Trasversali	0658	76	30	10
GIORGI GM. 30 - 32	Trasversali	0658	76	30	10
TRAUB A.15 - 20 - 25	Trasversali	0658	76	30	10
TRAUB A.15 - 20 - 25	Verticali	0659	90	45	10
TRAUB A.36 - 42 - 60	Trasversali	0662	96	40	12
TRAUB A.36 - 42 - 60	Verticali	0663	118	58	12
TRAUB TB.30 - 42 - 60	Trasversali - Verticali	0657	160	45	12

Al momento dell'ordine specificare **GRADI** e **CORSA**
 At the moment of the order specify **DEGREES** and **STROKE**

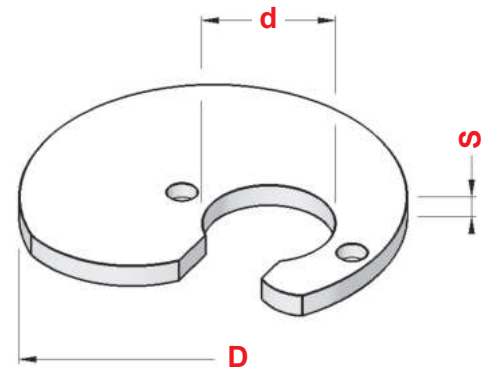

CAMME A DISCO PER RIBALTAMENTO APPARECCHIO FORO-FILETTI

DISK CAMS FOR DRILL-THREAD DEVICE

MACCHINA	Art.	D	d	S	Figura
TRAUB A.15 - 20 - 25	0514	90	36	5	1
TRAUB A.15 - 20 - 25	0515	90	36	5	2

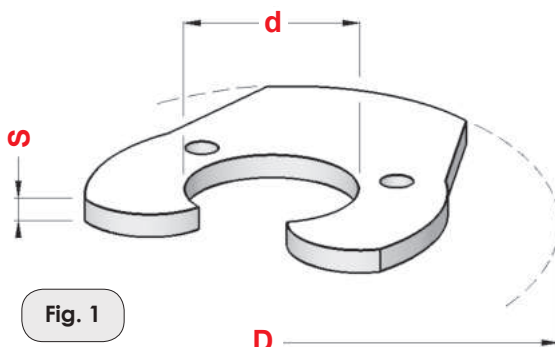

Fig. 1

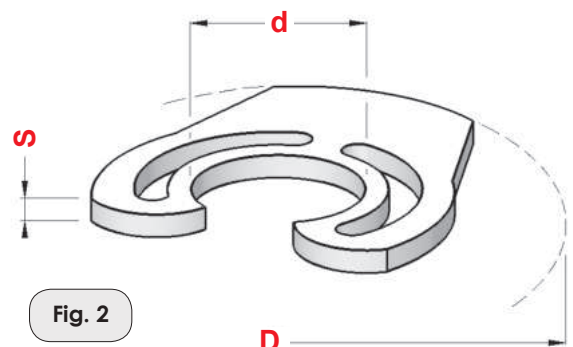

Fig. 2

TASTATORI IN ACCIAIO PER CAMME

STEEL TASTERS FOR CAMS

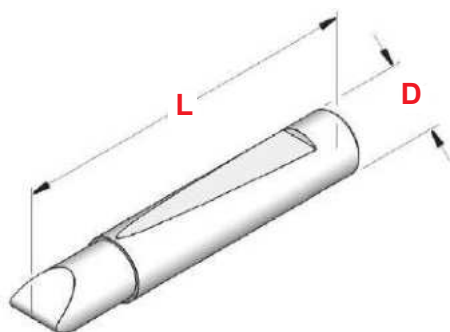

Fig. 1

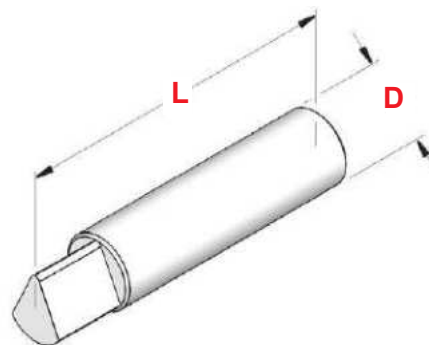
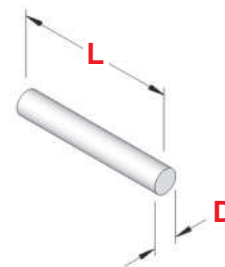
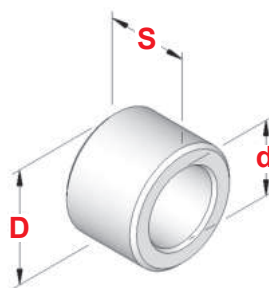
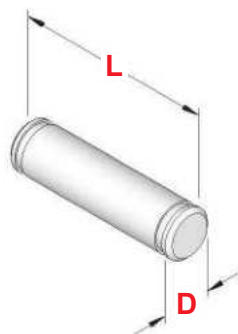
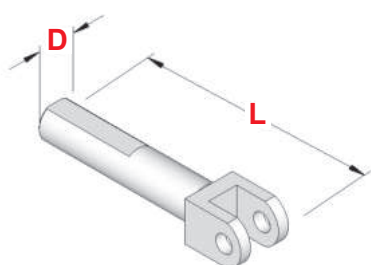

Fig. 2

MACCHINA	CARRI	Art.	D	L	Figura
GIORGI GM.20 - 25 - 32	Verticali - Orizzontali	1244	10	60	1
TRAUB A.15 - 20 - 25	Verticali - Orizzontali	1244	10	60	1
TRAUB A.15 - 20 - 25	Tornitura Longitudinale	0224	12	55	2
TRAUB A.36 - 42 - 60	Verticali - Orizzontali	1209	12	72	1
TRAUB A.36 - 42 - 60	Tornitura Longitudinale	0294	14	65	2
TRAUB TD.16 - 26 - 36	Verticali - Orizzontali	1244	10	60	1
TRAUB TB.30 - 42 - 60	Verticali	1209	12	72	1
TRAUB TB.30 - 42 - 60	Orizzontali	0567	16	60	1

SPINTORI PER CAMME STROHM 75 - 105 - 125

CAM PUSHERS FOR STROHM 75 - 105 - 125



MACCHINA	Posizione	Art.	D	L	Art.	D	L	Art.	D	d	S	Art.	D	L
STROHM 75-105-125	Fantina	1191	12	75	0288	6	23	1193	14,25	9,25	10	0442	1,5	9,8

PERNI E RULLI PER CAMME
PINS AND ROLLERS FOR CAMS

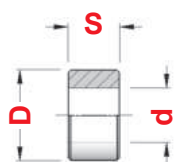

Fig. 1

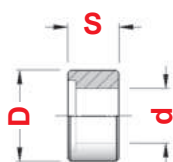

Fig. 2

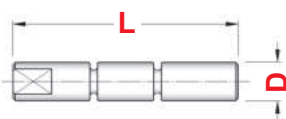

Fig. 4

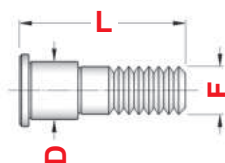

Fig. 6

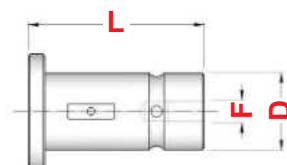

Fig. 8

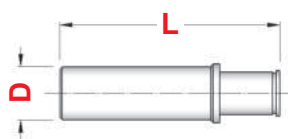

Fig. 11

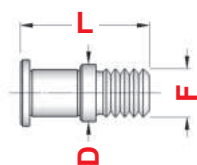

Fig. 12

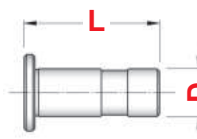

Fig. 13

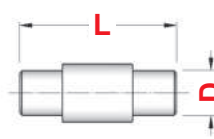
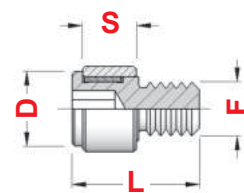

Fig. 14



Completo
Complete

MACCHINA	Posizione	Perno Pin					Rullo Roller					Rullini Needle Roller			Completo Complete
		Art.	D	L	F	Fig.	Art.	D	d	S	Fig.	Art.	D	L	Art.
GILDEMEISTER AS.32	Carri	2608	18	40	M5	8	2609	29,5	18	13	2	—	—	—	—
GILDEMEISTER AS.48	Carri	3201	20	45	M6	8	3202	30	20	15	2	—	—	—	—
GIORGI GM.20 - 25 - 32	Contropunta Ap.Ch. Pinza	0626	11	36	M10	6	0627	17	11	14	2	—	—	—	—
INDEX ON.12 - DG.12	Torretta / Carri	1801	6	28	—	4	0346	14	6	8	1	—	—	—	—
INDEX ON.12 - OR.12	Carri	—	—	—	—	—	0234	16	8	7,5	1	—	—	—	—
INDEX 12 - 18 - 25	Torretta / Carri	1589	6	36	—	4	0213	14	6	12	1	—	—	—	—
INDEX 24 - C19 - C29	Torretta / Carri	2701	7	40	—	4	2702	16	7	12	1	—	—	—	—
INDEX 36 - 42 - 52	Torretta / Carri	0360	8	46	—	4	1123	18	8	14	1	—	—	—	—
INDEX 42 - 60 - B.30	Torretta / Carri	0360	8	46	—	4	1123	18	8	14	1	—	—	—	—
INDEX DG.12 - OR.12	Doppio Scatto Torr.	—	—	—	—	—	—	—	—	—	—	—	—	—	1698
INDEX 12 - 18 - 25 - C19	Doppio Scatto Torr.	—	—	—	—	—	—	—	—	—	—	—	—	—	0124
TRAUB A.15 - 20 - 25	Tornitura Longit.	—	12	52	—	11	1577	16	12	10	1	—	—	—	0293
	Foro-Filetto	1162	12	24	M10	6	1577	16	12	10	1	—	—	—	—
	Foro-Filetto	0483	12	23	M10	12	1577	16	12	10	1	0478	1	6,8	1699
TRAUB TD.16 - 26 - 36	Contropunta Ap.Ch. Pinza	1700	12	35	M10	6	1577	16	12	10	1	—	—	—	—
	Torretta Ap.Ch. Pinza	0463	10	28	—	13	1959	20	10	8	1	—	—	—	—
	Torretta Ap.Ch. Pinza	0463	10	28	—	13	0494	20	13	8	1	0495	1,5	7,8	1988
	Guida Asta Torretta	0330	8	33	—	14	0331	12	8	10	1	—	—	—	—
TRAUB A.36 - 42 - 60	Tornitura Longit.	—	14	52	—	11	1577	16	12	10	1	—	—	—	1210
	Contropunta Ap.Ch. Pinza	1160	15	40	M12	6	1575	25	15	14	2	—	—	—	—
TRAUB TB.30 - 42 - 60	Fermo Barra Vert.	0483	12	23	M10	12	1577	16	12	10	1	0478	1	6,8	1699
	Torretta Ap.Ch. Pinza etc.	1683	15	34	M12	12	1684	22	15	12	2	0410	1,5	11,8	0551
	Guida Asta Torretta	0330	8	33	—	14	0331	12	8	10	1	—	—	—	—

DISPOSITIVO DI APERTURA E CHIUSURA PINZA TRAUB

OPENING-CLOSING COLLET DEVICE FOR TRAUB

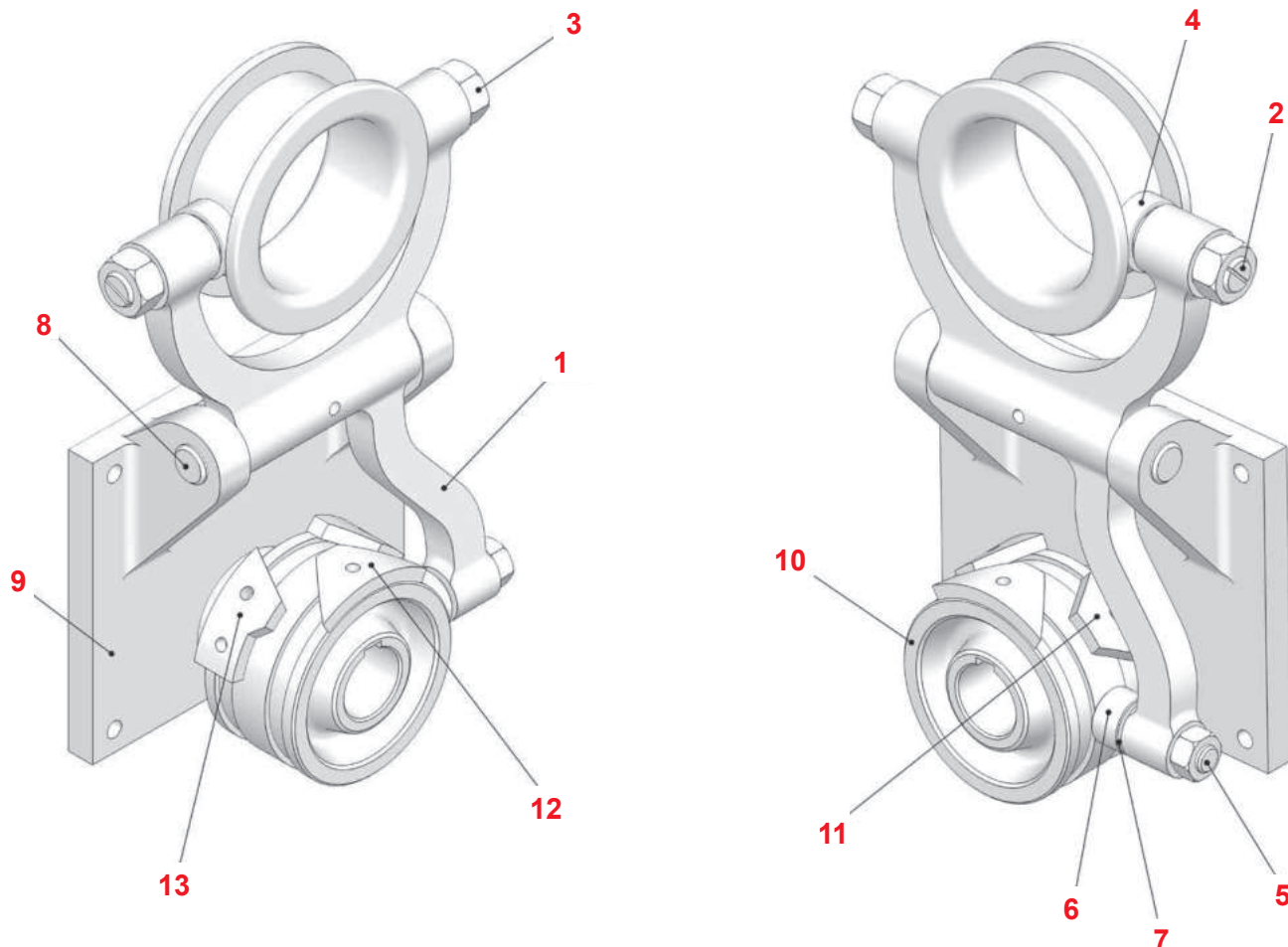

		TRAUB A.15 - 20 - 25	TRAUB A.36 - 42	TRAUB TB.30 - 42	TRAUB TB.60
Pos.	COMPONENTI	Art.	Art.	Art.	Art.
1	Leva Forcella	1837	1838	1302	1307
2	Perno Eccentrico per Cuscinetto	1168	1715	2104	2104
3	Dado	1169	1717	1717	1717
4	Cuscinetto	2360	2363	2524	2524
5	Perno per Rullo	1700	1160	1683	1683
6	Rullo	1577	1575	1684	1684
7	Rullini	—	—	0410	0410
8	Spina Fulcro Leva	1599	1433	1433	1433
9	Carter Supporto Leva	2188	1860	2185	2185
10	Porta Camme	1832	2168	2176	2176
11	Camme Contro	0636	2394	1443	1443
12	Camme Apertura	0637	2395	1444	1444
13	Camme Chiusura	0638	2396	1445	1445

PERNI PORTA CUSCINETTO PER APERTURA E CHIUSURA PINZA TRAUB

SHAFT JOURNAL FOR OPENING-CLOSING COLLET FOR TRAUB

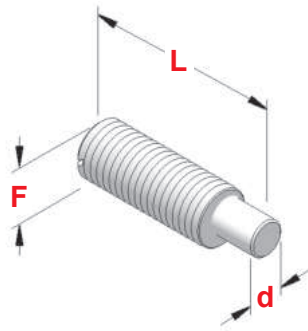

MACCHINA	Perno Pin		F	d	L	Eccentrico
	Art.					
TRAUB A.15 - 20 - 25	1168		12 x 1	10	43	0,75
TRAUB A.36 - 42 - 60	1715		16 x 1	12	54	1,5
TRAUB TB.30 - 42 - 60	2104		16 x 1	10	54,5	1,5

PERNI PORTA CUSCINETTO PER APERTURA E CHIUSURA PINZA INDEX

SHAFT JOURNAL FOR OPENING-CLOSING COLLET FOR INDEX

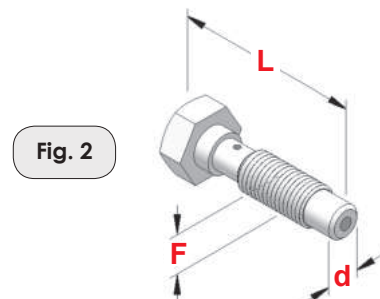
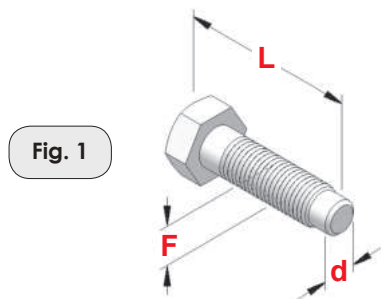

MACCHINA	Perno Pin		F	d	L	Fig.
	Art.					
INDEX 12 - 18 - 25	2541		10 x 1	8	33	1
	2542		10 x 1	8	41	1
INDEX C.19	2560		10 x 1	8	45	2
	2561		10 x 1	8	49	1
INDEX 24 - 36 - 52	2577		12 x 1	10	34	1
	2584		12 x 1	10	45	1
INDEX B.30 - 42	2638		12 x 1	10	53	1
	2639		12 x 1	10	53	2
INDEX B.60	2663		12 x 1	10	45	1
	2664		12 x 1	10	45	2

FERMO BARRA ORIZZONTALE

HORIZONTAL BAR STOP DEVICE

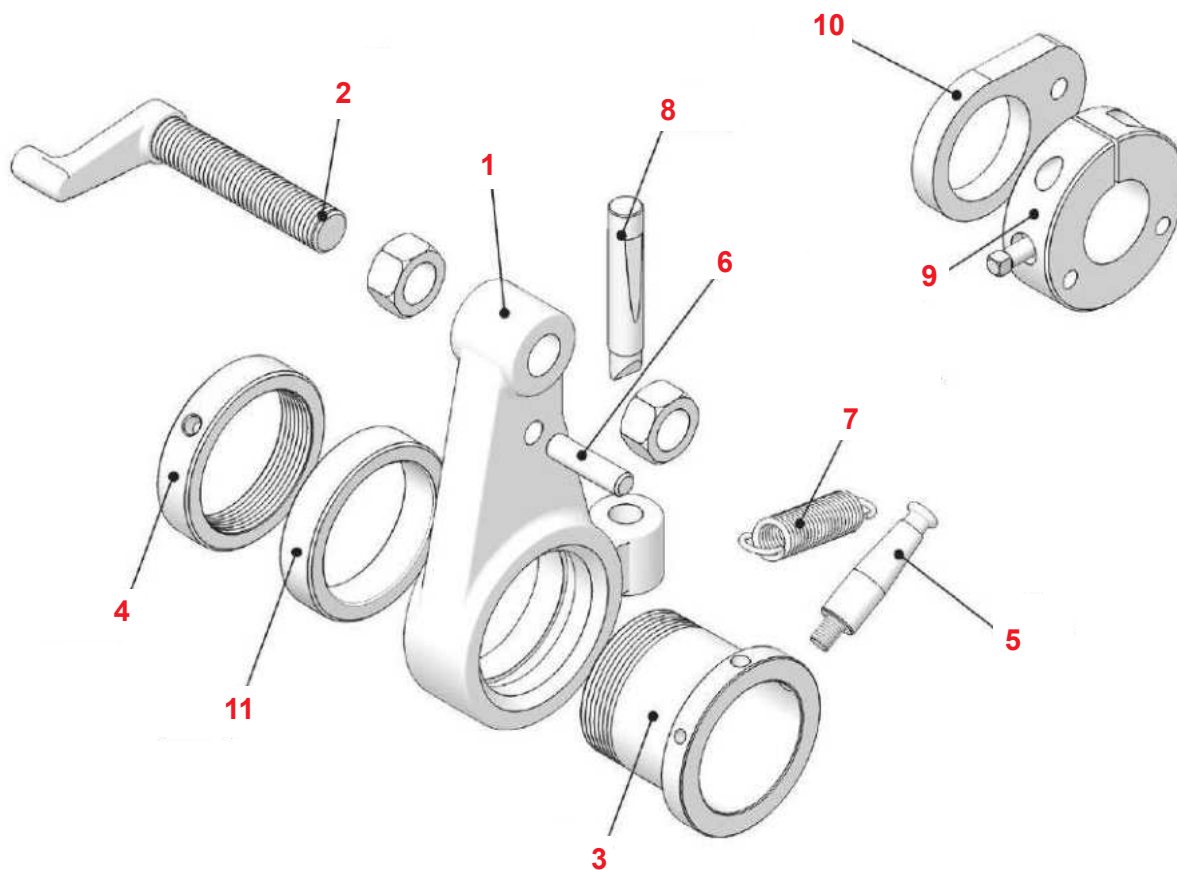

Pos.	COMPONENTI	TRAUB A.15 - 20 - 25		TRAUB A.36 - 42 - 60	GIORGI 25	
		Leva Diritta	Leva Curva	Leva Diritta	Leva Diritta	Leva Curva
		Art.	Art.	Art.	Art.	Art.
1	Leva	1841	1844	—	1841	1844
2	Puntalino Fermo Barra	0987	0981	0982	0987	0981
3	Bussola per Leva	1473	1473	1474	1473	1473
4	Ghiera di Registro	1523	1523	1268	1523	1523
5	Perno Lungo Tendi Molla	1155	1155	1155	1155	1155
6	Perno Corto Tendi Molla	0588	0588	0299	0588	0588
7	Molla di Trazione	0012	0012	0027	0012	0012
8	Tastatore	1244	1244	1209	1244	1244
9	Porta Camma	1430	1430	1345	1430	1430
10	Camma	0516	0516	0517	0516	0516
11	Anello di Battuta per Bussola	1178	1178	1248	1178	1178

FERMO BARRA VERTICALE TRAUB TB 30 - TB 42 - TB 60

VERTICAL BAR STOP DEVICE FOR TRAUB TB30 - TB42 - TB60

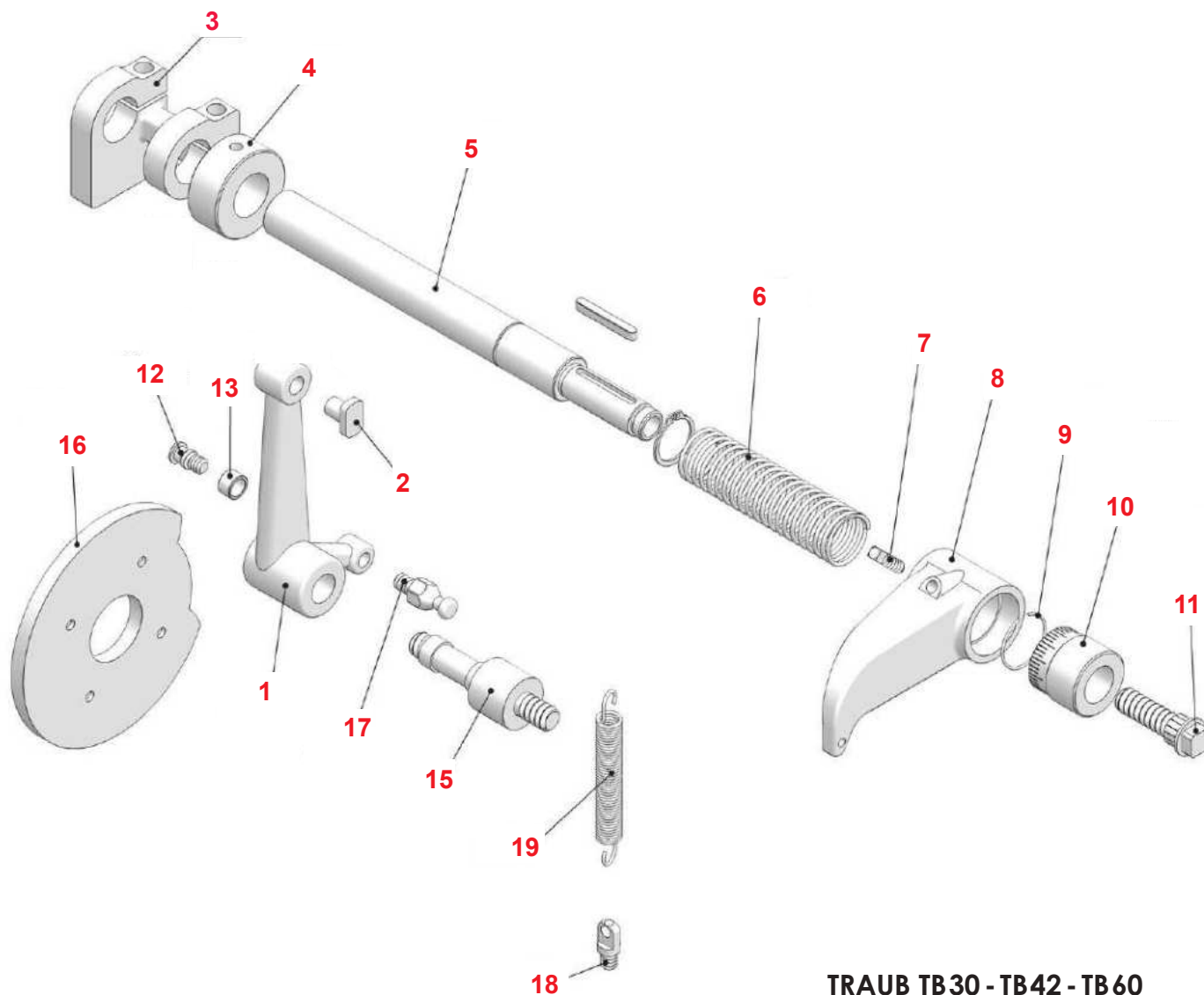

TRAUB TB 30 - TB42 - TB 60

Pos.	COMPONENTI	Art.
1	Leva di Comando	1949
2	Pastiglia Pattino	1950
3	Morsetto	1951
4	Anello di Battuta	2493
5	Albero	2494
6	Molla	2607
7	Vite di Bloccaggio	2148 8x30
8	Fermo Barra	2615
9	Molla a Tazza	2696
10	Nonio Graduato	2704
11	Vite di Registro	2710
12	Perno per Rullo	0483
13	Rullo per Camma	1577
14	Rullini	0478
15	Spina Fulcro Leva	2711
16	Camma	0596
17	Perno 1 per Molla	1097
18	Perno 2 per Molla	1098
19	Molla di Trazione	2655

CONTROPUNTA TRAUB

TAILSTOCK FOR TRAUB

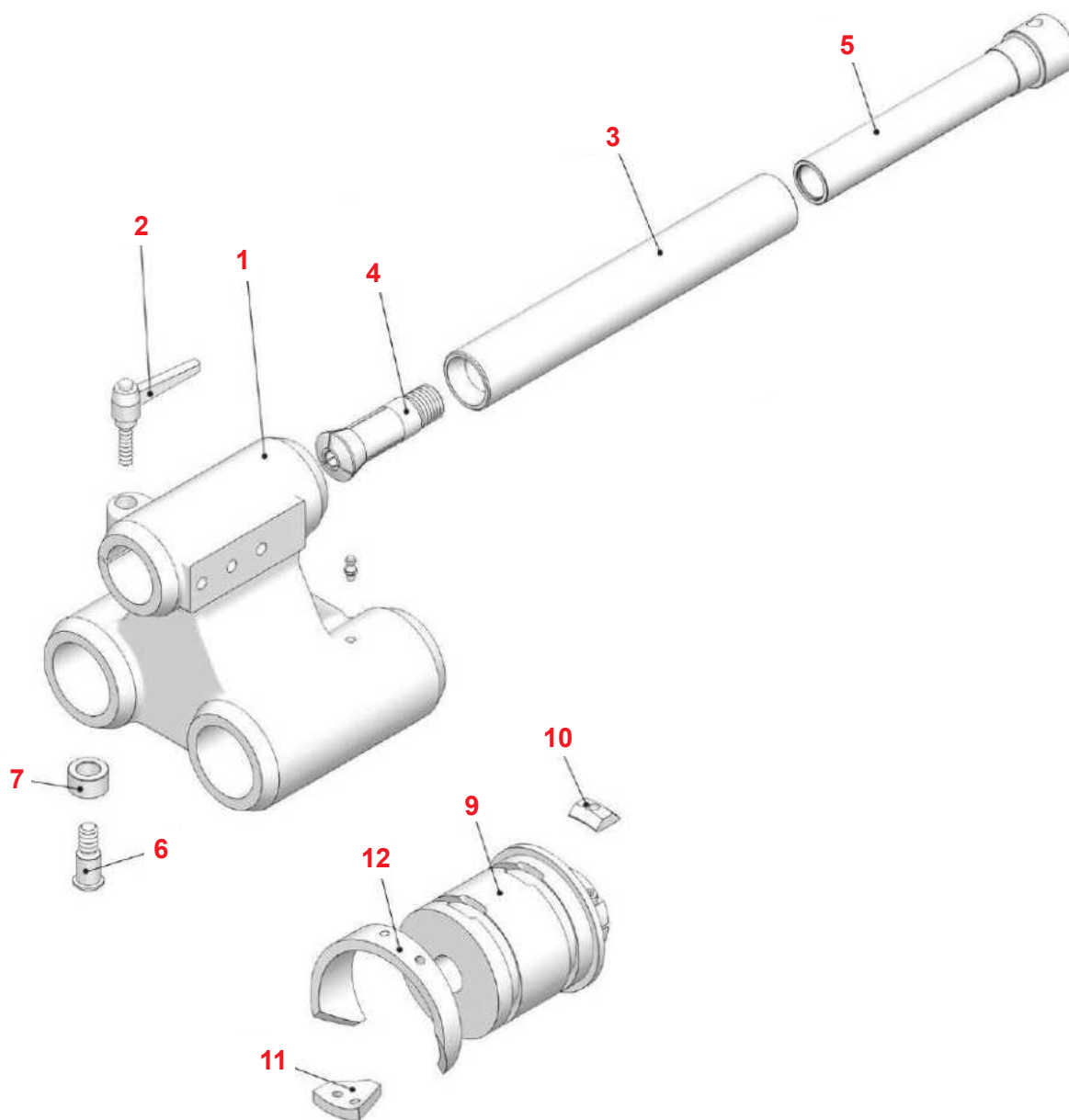

		TRAUB A.15 - 20 - 25	TRAUB A.36 - 42 - 60	TRAUB TB.30 - 42 - 60
Pos.	COMPONENTI	Art.	Art.	Art.
1	Contropunta con Maniglia	2150	2146	—
2	Maniglia	2257	2337	Viti / Screws
3	Canotto Porta Pinza	1482	1827	1827
4	Pinza	0750	0751	0751
5	Tirante	1077	1481	1481
6	Perno per Rullo	1700	1160	1683
7	Rullo	1577	1575	1684
8	Rullini	—	—	0410
9	Porta Camme	1979	2144	2164
10	Tassello Curvo	1147	1148	1148
11	Camma Ritorno	0511	0512	0512
12	Camma Foratura	0660	0664	0664

CANOTTI E TIRANTI PER CONTROPUNTA

SLEEVES AND BOLTS FOR TAILSTOCK

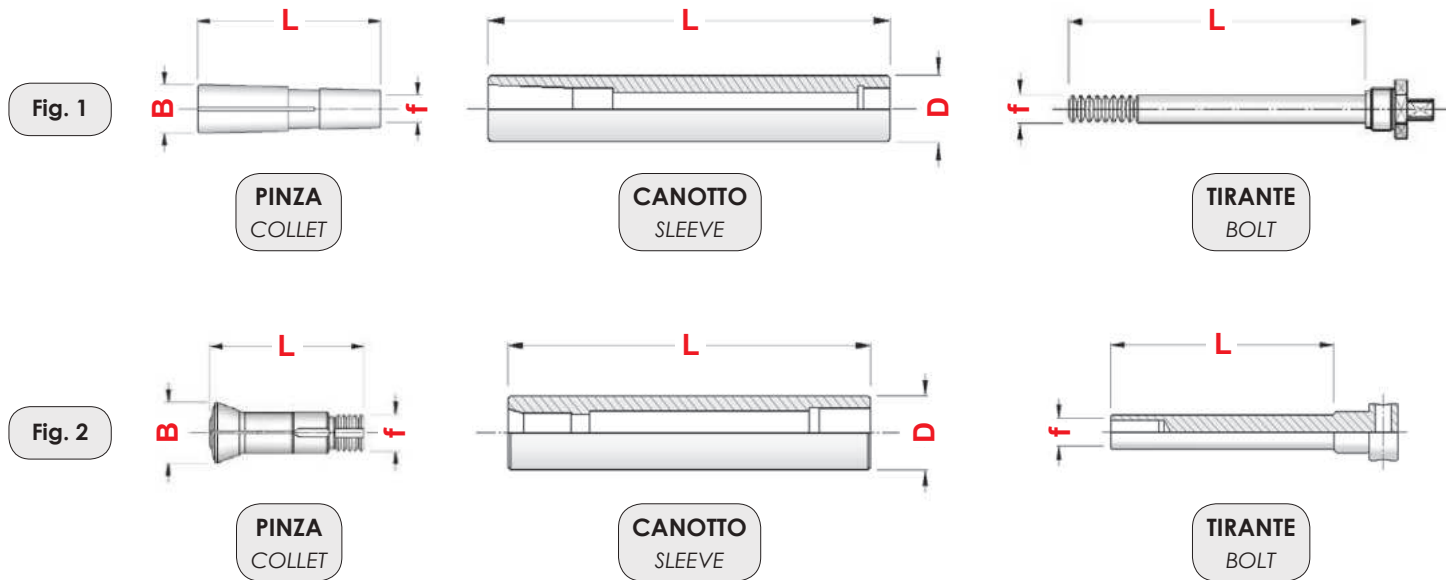

MACCHINA	Posizione	Fig.	Pinza Collet				Canotto Sleeve			Tirante Bolt			
			Art.	Einheits	f	B	L	Art.	D	L	Art.	f	L
GIORGI GM.32	Contropunta - Tailstock	1	0752	503E	M10	18	69	2861	32	190	1965	M10	125
TRAUB A.15 - 20 - 25	Contropunta - Tailstock	2	0750	324E	13x1	21,5	55	1482	30	178	1077	13x1	138
	Fora Filetti - Drill Thread	2	0750	324E	13x1	21,5	55	1065	30	230	1078	13x1	190
TRAUB A.36 - 42 - 60	Contropunta - Tailstock	2	0751	363E	23x1	33,5	88	1827	40	268	1481	23x1	202
TRAUB TB.42 - 60	Contropunta - Tailstock	2	0751	363E	23x1	33,5	88	1827	40	268	1481	23x1	202

CANOTTI A DOPPIO CONO MORSE INTERNO PER CONTROPUNTA

SLEEVES WITH INNER DOUBLE MORSE TAPER FOR TAILSTOCK

MACCHINA	TIPO	Art.	D	L
GIORGI GM.20 - 25 - 32	CM / 2 - 3	2816	32	200
TRAUB A.15 - 20 - 25 etc.	CM / 1 - 3	1085	30	200
	CM / 2 - 3	2798	30	200
TRAUB TD.16 - 26 - 36	CM / 1 - 3	1085	30	200
	CM / 2 - 3	2798	30	200
TRAUB A.36 - 42 - 60	CM / 2 - 4	2843	40	270
TRAUB TB.30 - 42 - 60	CM / 2 - 4	2843	40	270

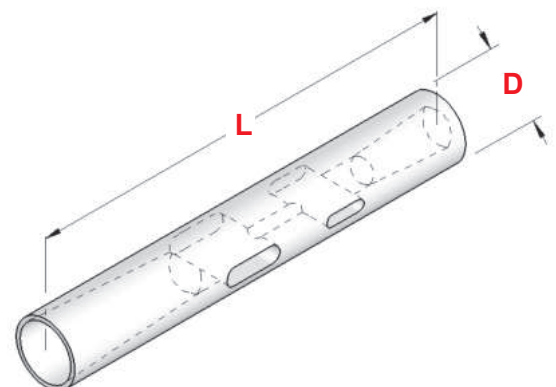

APPARECCHIO FORO-FILETTI TRAUB A 15 - A 20 - A 25

DRILL-THREAD DEVICE FOR TRAUB A 15 - A 20 - A 25

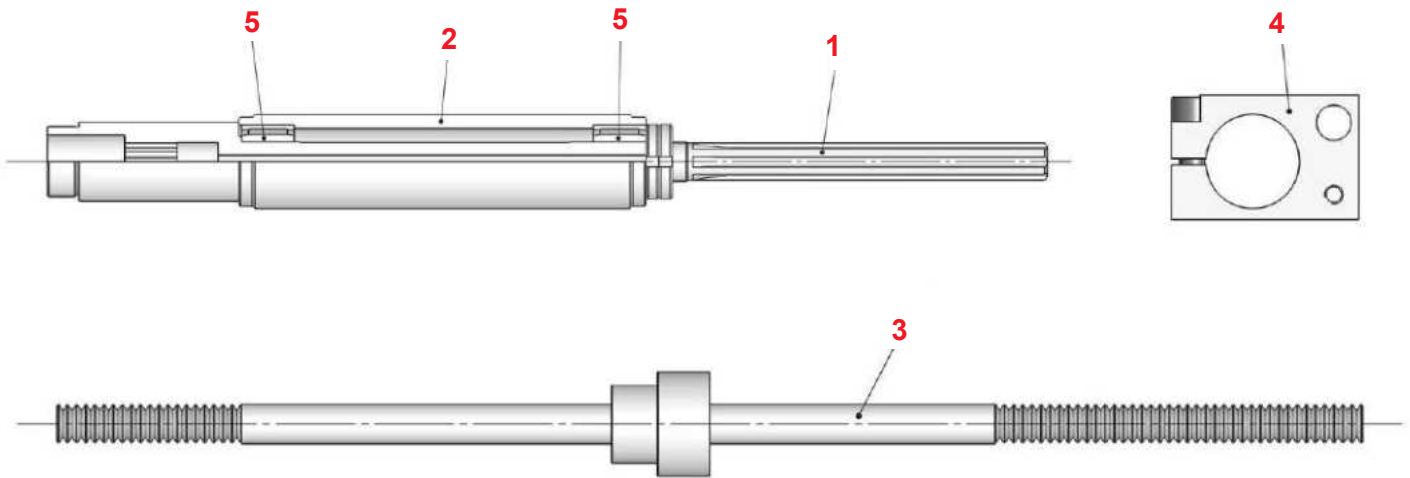

Pos.	COMPONENTI	Art.
1	Albero Scanalato Corto	0984
	Albero Scanalato Lungo	2084
2	Canotto per Albero Corto	2782
	Canotto per Albero Lungo	2784
3	Tirante per Albero Lungo	0983
4	Morsetto Blocca Canotti	2569
5	Cuscinetti a Rullini	—

SPINTORE PER APPARECCHIO FORO-FILETTI TRAUB A 15 - A 20 - A 25

DRILL-THREAD DEVICE PUSHER FOR TRAUB A.15 - 20 - 25

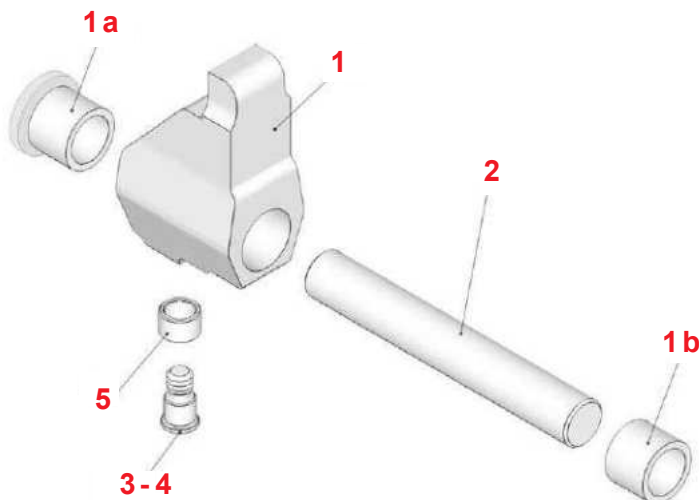

Pos.	COMPONENTI	Art.
1	Spintore Completo di Boccole	1488
1a	Boccola Anteriore	2793
1b	Boccola Posteriore	2794
2	Albero d. 20	1974
3	Perno per Rullo Senza Rullini	1162
4	Perno per Rullo Con Rullini	0483
5	Rullo	1577
—	Rullini	0478

MANDRINI PER APPARECCHIO FORO-FILETTI TRAUB A15 - A20 - A25

HOLDERS FOR DRILL-THREAD DEVICE FOR TRAUB A15 - A20 - A25

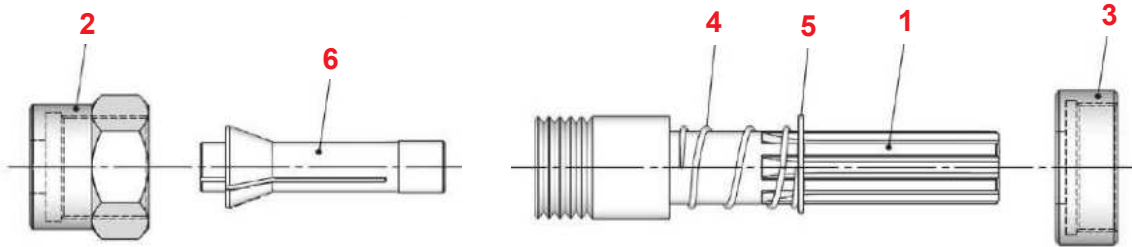

PORTA MASCHI / PORTA PUNTE

TAPPING HOLDER / DRILL HOLDER

Pos.	COMPONENTI	Art.
1	Alberino Scanalato (con ghiera)	1184
2	Ghiera	1182
3	Anello di Fissaggio per Alberino	1081
4	Molla	1080
5	Seeger	1079
6	Pinza	0725

COMPLETO		Art.
Completo Mandrino Porta Maschi Posizioni da 1 a 5		7332

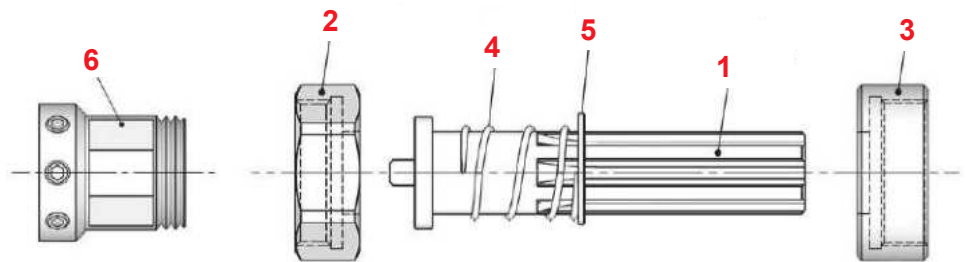

PORTA FILIERA

THREADING DIE HOLDER

Pos.	COMPONENTI	Art.
1	Alberino Scanalato	1070
2	Ghiera	1071
3	Anello di Fissaggio per Alberino	1081
4	Molla	1080
5	Seeger	1079
6	Porta Filiera - Specificare dimensioni della filiera Threading die - Specify threading die dimensions	

COMPLETO		Art.
Completo Mandrino Porta Filiera Posizioni da 1 a 5		7334

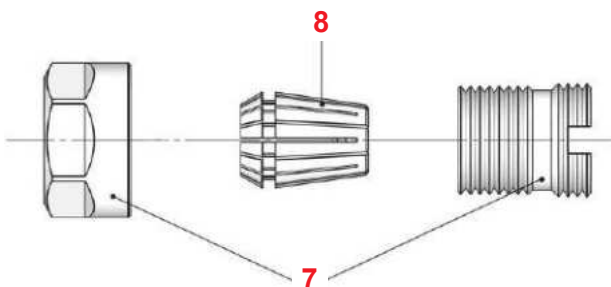

APPLICAZIONE PORTA PINZA ER

ER COLLET HOLDER APPLICATION

Pos.	COMPONENTI	Art.
7	Mandrino Portapinza ER 20 con ghiera	2633
8	Pinza ER 20	0787
	Pinza ER 20 con Quadro per Maschi	0787 MF

GRUPPO FRIZIONE TRAUB

CLUTCH DEVICE FOR TRAUB

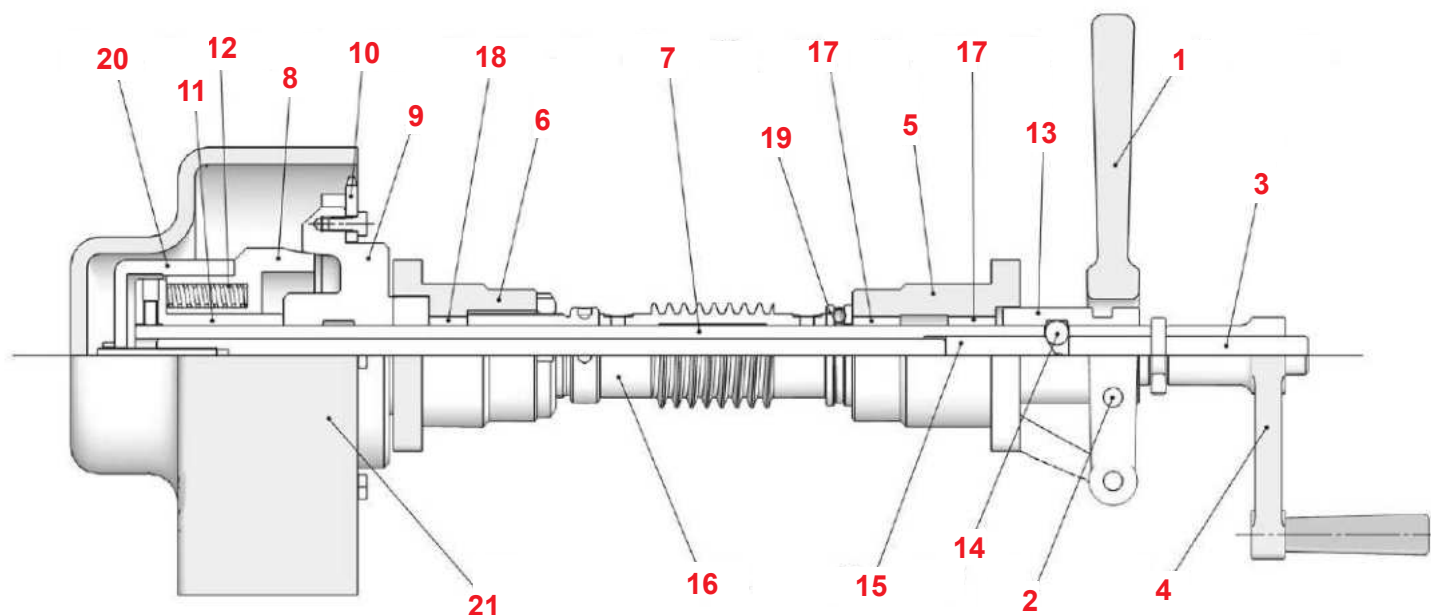

Pos.	COMPONENTI	TRAUB	TRAUB
		A.15 - 20 - 25	A.36 - 42 - 60
		Art.	Art.
1	Leva di innesto	1313	1314
2	Pastiglia di Innesto	0583	0387
3	Spina di Innesto	—	—
4	Manovella	1846	1847
5	Supporto Anteriore per Albero	2238	—
6	Supporto Posteriore per Albero	—	—
7	Albero	1315	1328
8	Cono di Accoppiamento	1319	2457
9	Disco di Accoppiamento	1329	2455
10	Corona Dentata Z.45 (Foro d. 75)	1299	—
	Corona Dentata Z.45 (Foro d. 95)	—	2387
11	Bussola per Molle	1638	0606
12	Molle	0032	0419
13	Bussola Scorrevole per Sfere	1586	2398
14	Sfere	d. 8	d. 10
15	Perno di Spinta Sfere	0300	—
16	Vite Senza Fine	1436	1437
17	Cuscinetto a Rullini Anteriore	0343	0428
18	Cuscinetto a Rullini Posteriore	0344	0429
19	Cuscinetto a Sfere	0345	0435
20	Calotta di Chiusura	0332	1220
21	Carter	—	—

VITI SENZA FINE E CORONE IN BRONZO PER FRIZIONE TRAUB E STROHM

WORMS AND WORM WHEELS FOR TRAUB AND STROHM CLUTCH

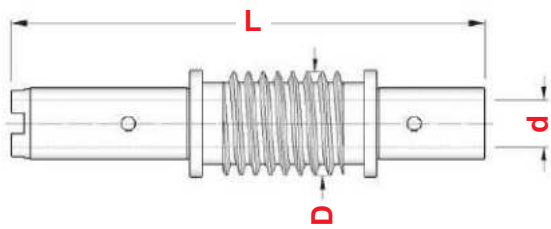

Fig. 1

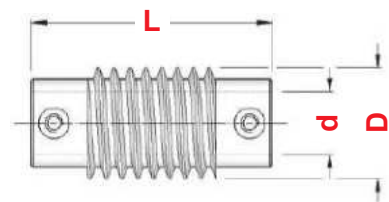

Fig. 2

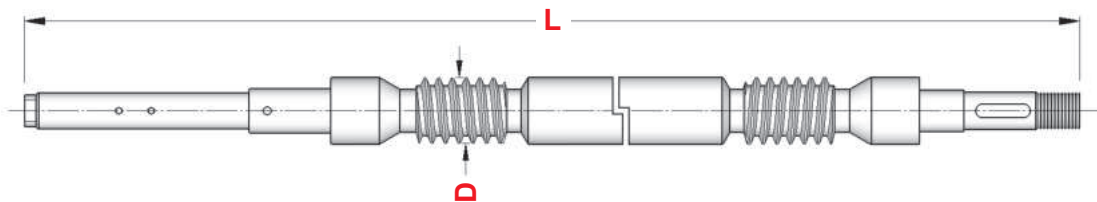

Fig. 3

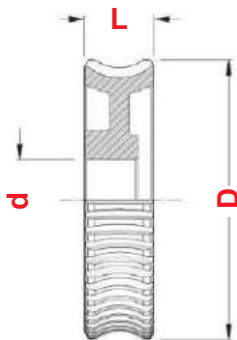

Fig. 4

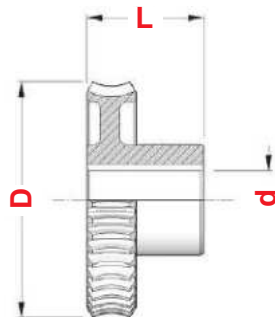

Fig. 5

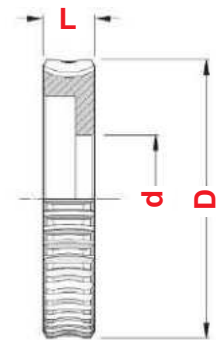

Fig. 6

MACCHINA	VITI SENZA FINE WORMS					
	Art.	d	D	L	Elica	Fig.
STROHM 75 - 105 - 125	1438	16	38	202	DX	1
STROHM 205 - 255	1439	18	42,5	252	DX	1
TRAUB A.15 - 20 - 25	1436	20	40	60	DX	2
TRAUB TD.16 - 26 - 36	2206	-	30	584	DX - SX	3
TRAUB A.36 - 42 - 60	1437	25	43,8	95	DX	2
TRAUB TB.30 - 42 - 60 (Post.)	1437	25	43,8	95	DX	2
TRAUB TB.30 - 42 - 60 (Ant.)	1713	25	43,8	95	SX	2

Art.	CORONE IN BRONZO WORM WHEELS				
	d	D	L	Elica	Fig.
0992	22	96	35	DX	5
0993	28	133	52	DX	5
0994	25	96	48	DX	5
1558	56	114	22	DX	6
1557	56	114	22	SX	6
0995	35	122	30	DX	4
2331	35	122	52	DX	5
1326	35	122	52	SX	5

ALBERI PORTA CAMME PER FANTINA TRAUB

CAM SHAFT HOLDERS FOR TRAUB SLIDING HEADSTOCK

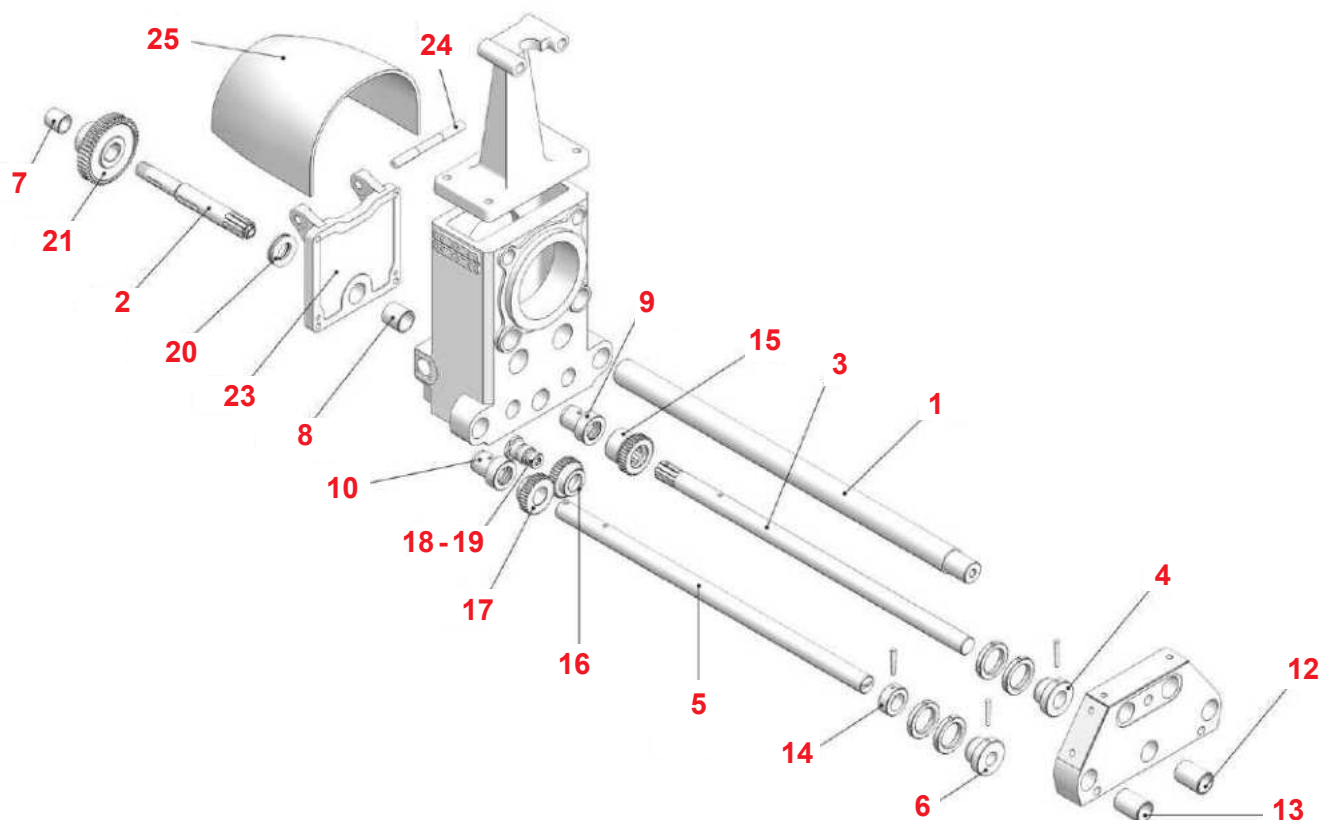

	TRAUB A.15 - 20 - 25	TRAUB A.36 - 42 - 60
--	-------------------------	-------------------------

Pos.	COMPONENTE	Art.	Art.
1	Albero di Guida Contropunta	2138	4960
2	Albero Centrale Porta Corona	1320	1476
3	Albero Centrale Porta Camme	2132	3022
4	Boccola di Registro Completa per Albero Centrale	0162	—
5	Albero Laterale Anteriore Porta Camme	2133	3021
	Albero Laterale Posteriore Porta Camme	2133	3021
6	Boccola di Registro Completa per Albero Laterale	—	—
7	Boccola Intermedia	2575	—
8	Boccola di Guida per Albero Corona	1088	2725
9	Boccola Anteriore per Albero Centrale Fantina	1434	1886
10	Boccola Albero Laterale per Fantina	1434	1885
11	Boccola Posteriore Albero Centrale Fantina	—	—
12	Boccola Albero Centrale per Supporto	1435	1936
13	Boccola Albero Laterale per Supporto	1435	1935
14	Anello di Fermo per Albero Laterale	1618	—
15	Ingranaggio per Albero Centrale	1408	1878
16	Ingranaggio Intermedio	1407	—
17	Ingranaggio per Albero Laterale	1385	1550
18	Perno per Ingranaggio Intermedio	1263	1198
19	Vite di Bloccaggio per Perno	0539	2730
20	Cuscinetto per Albero Corona	0435	2748
21	Corona in Bronzo	0994	0995
23	Carter per Forcella	2188	1860
24	Spina Fulcro Leva	1599	1433
25	Carter Copri Manicotto	—	—

PERNI E BOCCOLE PORTA INGRANAGGI PRODUZIONE

PINS AND SLEEVES PRODUCTION GEARS HOLDER

Boccola
Sleeve



Perno
Pin

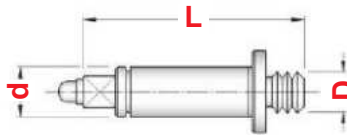

Fig. 1

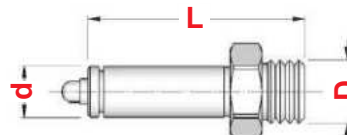

Fig. 2

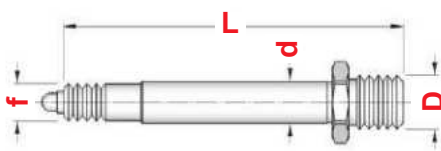

Fig. 4

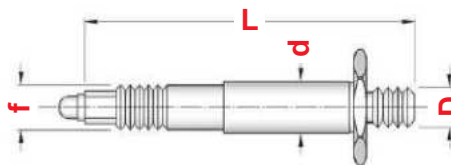

Fig. 5

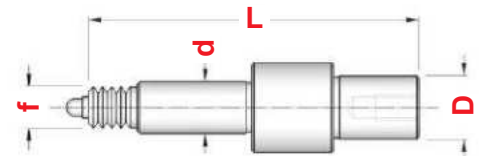

Fig. 6

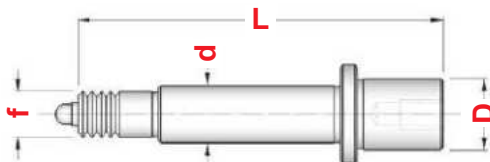

Fig. 7

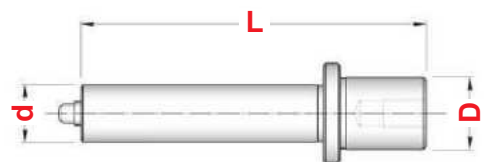

Fig. 8

MACCHINA	Posizione	Perno Pin						Boccola Sleeve				Art.	Dimens.	Art.
		Art.	D	d	L	f	Fig.	Art.	D	d	L			
GIORGI GM. 20	Superiore - Up	1920	18x2,5	16	96	-	2	1941	23	16	35	1681	5x5x30	1124
	Centrale - Mid	1921	12x1,75	16	74	-	1	1941	23	16	35	1681	5x5x30	
	Inferiore - Low	1923	18x2,5	16	116	-	2	1942	23	16	70,5	1682	5x5x65	
TRAUB A.15 - 20 - 25	Superiore - Up	1118	20x1,5	16	68	-	2	1117	22	16	38	1674	6x4x30	1124
	Centrale - Mid	1116	12x1,75	16	69	-	1	1115	22	16	36	1674	6x4x30	
	Inferiore - Low	1120	20x1,5	16	90	-	2	1119	22	16	62	0571	6x4x55	
TRAUB A.36 - 42 - 60	Superiore - Up	1112	20x1,5	16	126	14x2	4	1111	22	16	47	0570	6x4x35	-
	Centrale - Mid	1114	12x1,75	16	99	14x2	5	1113	22	16	40	1674	6x4x30	-
	Inferiore - Low	1110	20x1,5	16	126	14x2	4	1109	22	16	71	1685	6x4x60	-
TRAUB TB.30 - 42 - 60	Superiore - Up	1597	25	20	129	16x2	7	1598	30	20	64	1686	8x7x55	-
	Centrale - Mid	1595	25	16/20	117	-	6	1596	30	20	41	0579	8x7x30	-
	Inferiore - Low	2736	25	20	130	16x2	6	1596	30	20	41	0579	8x7x30	-
	-	2738	25	20	121	-	8	1598	30	20	64	1686	8x7x55	-

FLANGE E CORONE PER CATENA TRAUB

FLANGE AND CHAIN GEARS FOR TRAUB

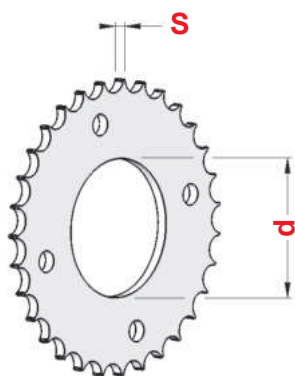

Fig. 1

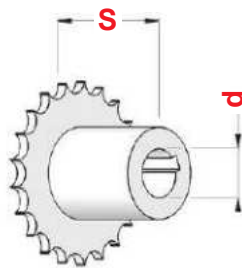

Fig. 2

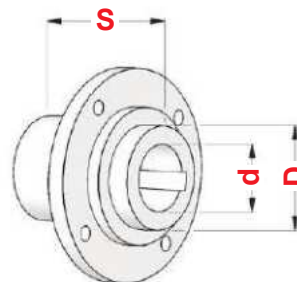

Fig. 3

MACCHINA	Posizione - Position	CORONE PER CATENA CHAIN GEARS					FLANGE FLANGE				
		Art.	Z	d	S	Figura	Art.	D	d	S	Figura
TRAUB A.15 - 20 - 25	Pompa Acqua - Water Pump	0652	Z 17	12	22	2	—	—	—	—	—
	Motore - Engine	1186	Z 17	20	3,5	1	1993	20	14	43	—
	Trasmissione - Drive	1187	Z 27	45	3,5	1	2217	45	22	29	3
	Tendi Catena - Chain Tightener	1187	Z 27	45	3,5	1	2388	45	16	22	3
	Frizione - Clutch	1299	Z 45	75	3,5	1	1329	—	—	—	—
	Trasmissione - Drive	1300	Z 65	150	3,5	1	2218	150	22	48	3
TRAUB A.36 - 42 - 60	Motore - Engine	1971	Z 17	25	5,5	1	—	—	—	—	—
	Trasmissione - Drive	2386	Z 27	45	5,5	1	2217	45	22	29	3
	Tendi Catena - Chain Tightener	2386	Z 27	45	5,5	1	2388	45	16	22	3
	Trasmissione - Drive	1497	Z 65	150	5,5	1	2075	150	22	55	3
TRAUB A.36 - 42	Frizione - Clutch	1602	Z 45	75	5,5	1	—	—	—	—	—
TRAUB A.60	Frizione - Clutch	2387	Z 45	95	5,5	1	2455	—	—	—	—

INGRANAGGI PER PRODUZIONE TRAUB

GEARS FOR TRAUB PRODUCTION

MACCHINA	CAMBIO PRODUZIONE PRODUCTION GEAR SHIFT				
	Art.	Z	Modulo	d	H
TRAUB A.15-20-25	1038	25	1,25	22	16
	1039	35			
	1040	40			
	1041	45			
	1042	50			
	1050	75			
	1051	80			
	1052	90			
1053	100				

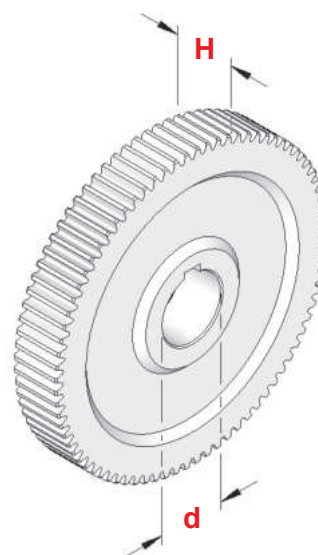

POMPA PER ACQUA TRAUB A15 - A20 - A25

COOLING PUMP FOR TRAUB A15 - A20 - A25

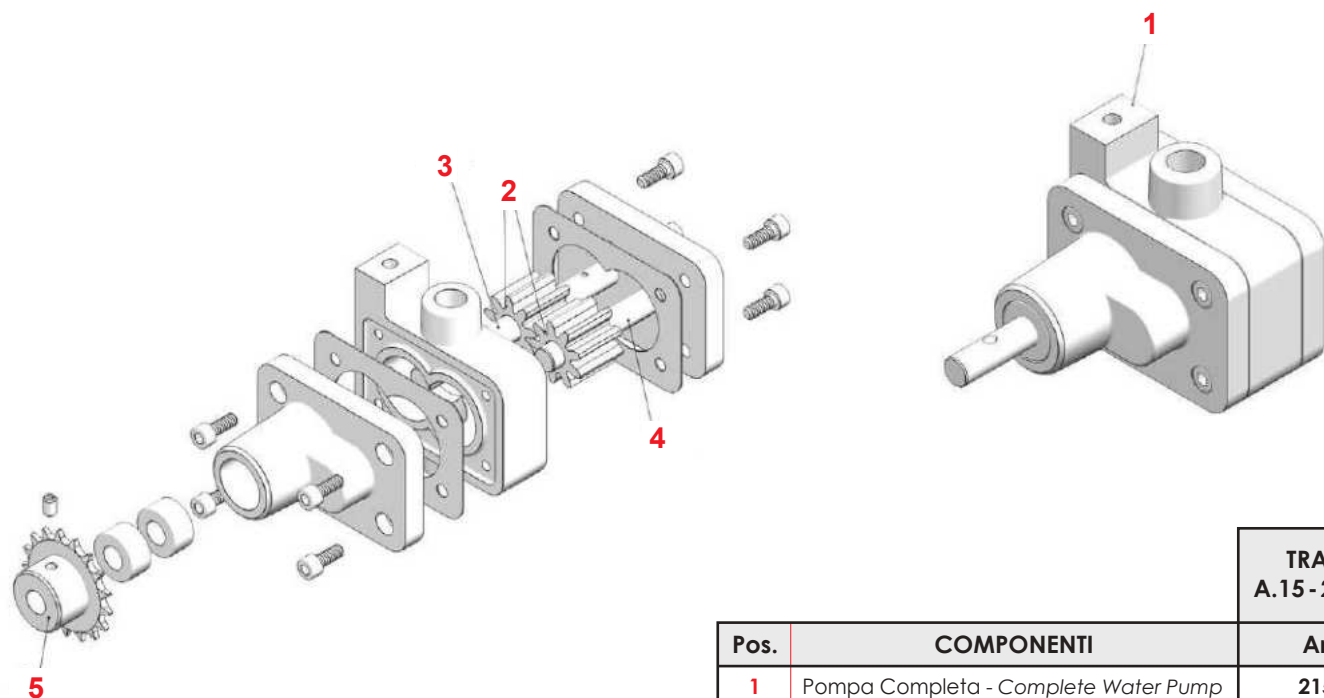

TRAUB A.15 - 20 - 25		
Pos.	COMPONENTI	Art.
1	Pompa Completa - Complete Water Pump	2153
2	Ingranaggi - Gears	1522
3	Alberino Lungo - Long Shaft	1277
4	Alberino Corto - Short Shaft	1276
5	Mozzo per Catena - Chain Hub	0652

CAPPOTE DI PROTEZIONE TRAUB A15 - A20 - A25

OILSPASH COVERS FOR TRAUB A15 - A20 - A25

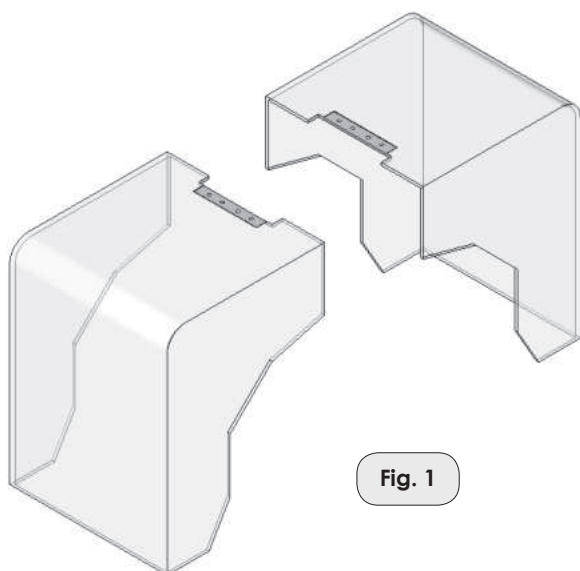
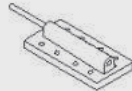

Fig. 1

MACCHINA	Art.	Figura
TRAUB A.15 - 20 - 25	3032	1

Cerniera Hinge

Art.
3035

BANDIERINE SPINGIBARRA ROTANTI TRAUB A 15 - A 25

REVOLVING BAR PUSHERS FOR TRAUB A 15 - A 25

Rotante
Revolving



MACCHINA	Art.	D	L
TRAUB A.15	3006	14	490
TRAUB A.25	3009	24	500

Art.	D	d	H
2108	14,5	12	23
2162	24	20	38

Le bandierine vengono fornite complete di rotante
Revolving bar pusher are supplied complete with revolving

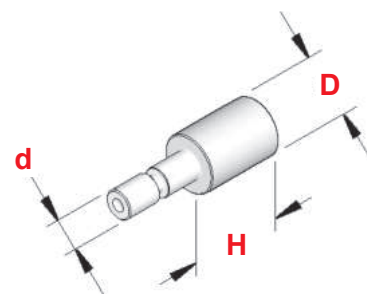
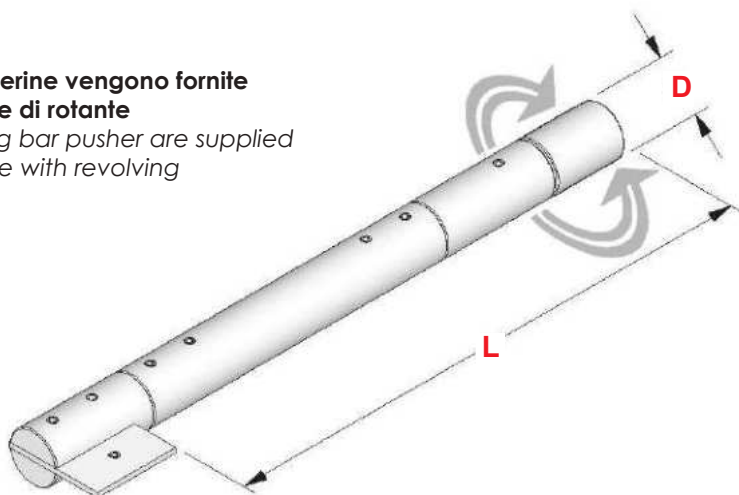

CONTAGIRI

REVOLUTIONS COUNTERS

CONTACOLPI

STROKES COUNTERS

Fig. 1

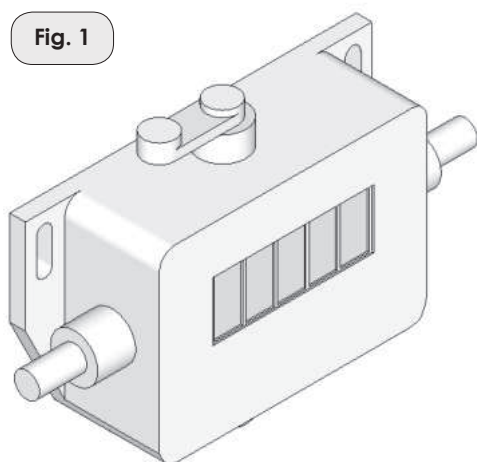
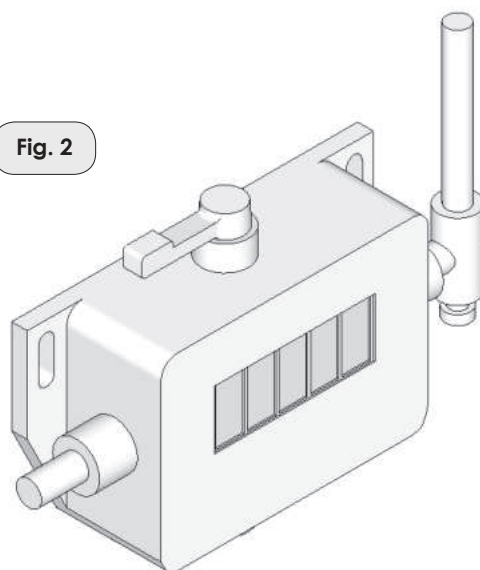

Fig. 2



CONTAGIRI TIPO	Art.	Figura	Cifre
CONTAGIRI DESTRO Right Revolutions Counter	1166	1	5
CONTAGIRI SINISTRO Left Revolutions Counter	1167	1	5

CONTACOLPI TIPO	Art.	Figura	Cifre
CONTACOLPI DESTRO Right Strokes Counter	1728	2	5
CONTACOLPI SINISTRO Left Strokes Counter	1729	2	5

MANDRINO PRINCIPALE STROHM 125

MAIN SPINDLE FOR STROHM 125

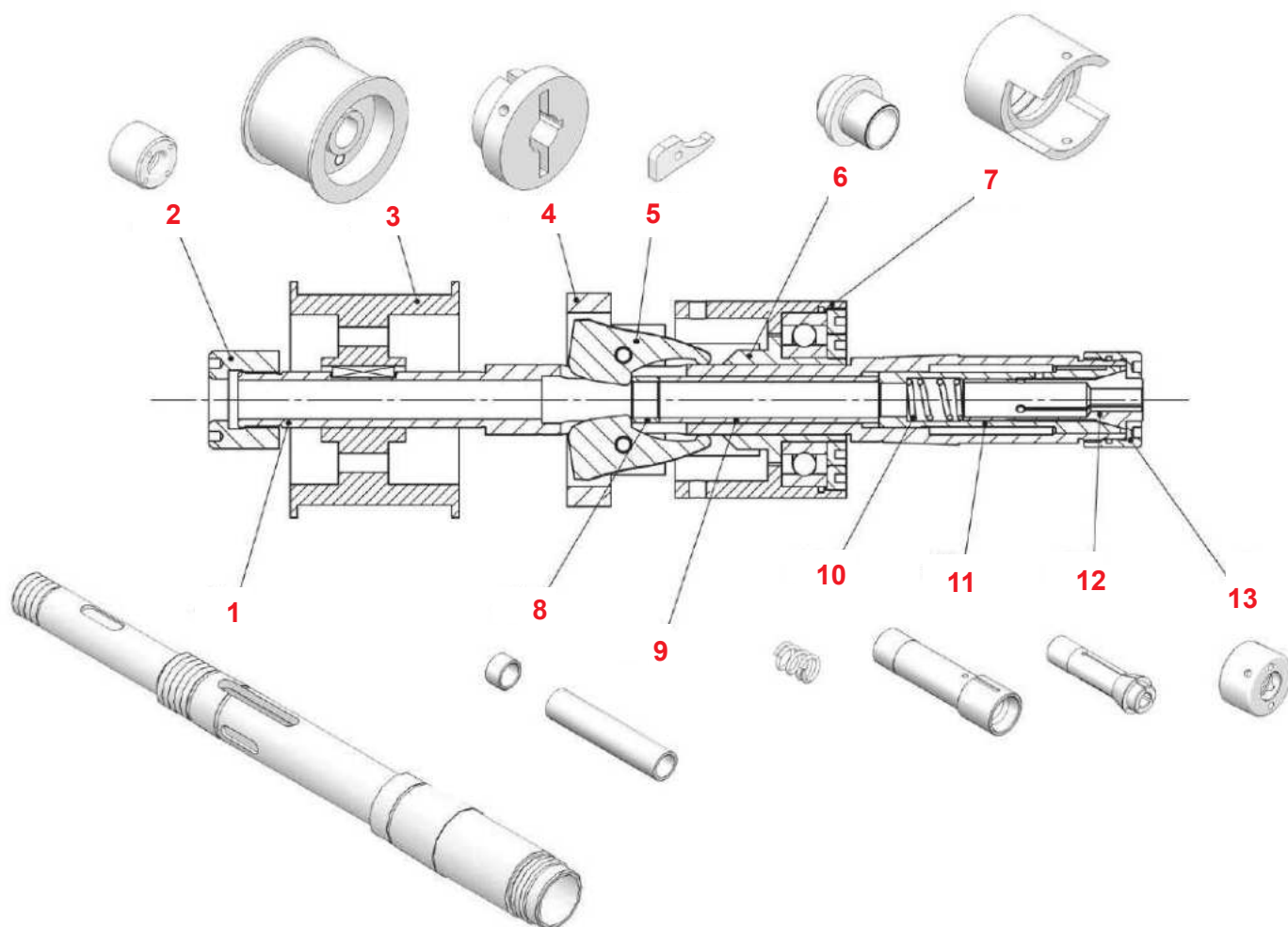
**STROHM 125**

Pos.	COMPONENTI	Art.
1	Mandrino Principale	2134
2	Ghiera Registro Manicotto	2106
3	Puleggia Velocità	—
4	Blocco Porta Leve	2049
5	Levette di chiusura	0791
6	Anello Scorrevole	1440
7	Corpo Esterno	1754
8	Distanziale Compensatore	1175
9	Tubo spingi Pinza	2020
10	Molla per Bicchiere	1273
11	Bicchiere Porta Pinza	1752
12	Pinza di Serraggio	0722
13	Ghiera di Serraggio Pinza	0398

GRUPPO FRIZIONE STROHM 75 - 105 - 125

CLUTCH DEVICE FOR STROHM 75 - 105 - 125

**STROHM
75 - 105 - 125**

Pos.	COMPONENTI	Art.
1	Albero scanalato	2501
2	Cono frizione scanalato	2614
3	Manicotto frizione	2044
4	Boccola in tela M.80 x 1,5	2602

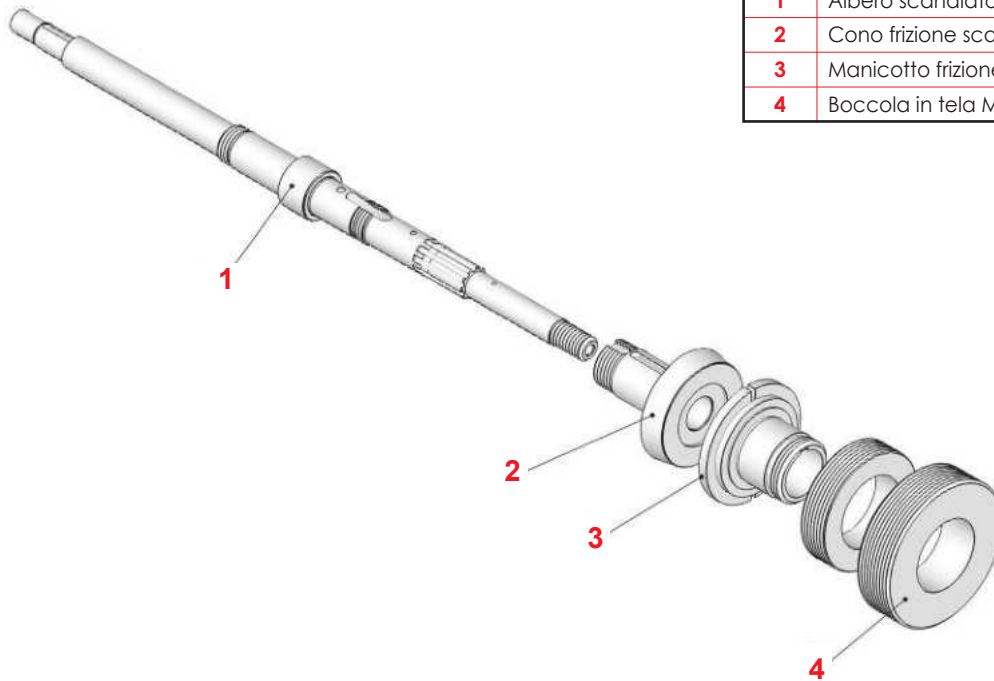

APPARECCHIO COMBINATO 3 MANDRINI STROHM 75 - 105 - 125

3 SPINDLE COMBI DEVICE FOR STROHM 75 - 105 - 125

**STROHM
75 - 105 - 125**

Pos.	COMPONENTI	Art.
1	Mandrino a Filettare	1200
2	Cono Porta Filiera D.8	0396
3	Mandrino a Forare	1201
4	Pinza	0721
5	Ghiera serraggio Pinza	0308
6	Ingranaggio Z.18 - L.10 - Foro 13	1259
7	Ingranaggio Z.18 - L.21 - Foro 13	1258
8	Forcella di Bloccaggio	—
9	Perno per Pattino - M8 - L.23	2637
10	Pattino di Scorrimento	2636
11	Albero Eccentrico	0997
12	Bronzina D.21/18 - L.70 - Foro 13	1204
13	Bronzina D.18 - L.50 - Foro 13	1205
14	Bronzina D.18 - L.24 - Foro 13	1206

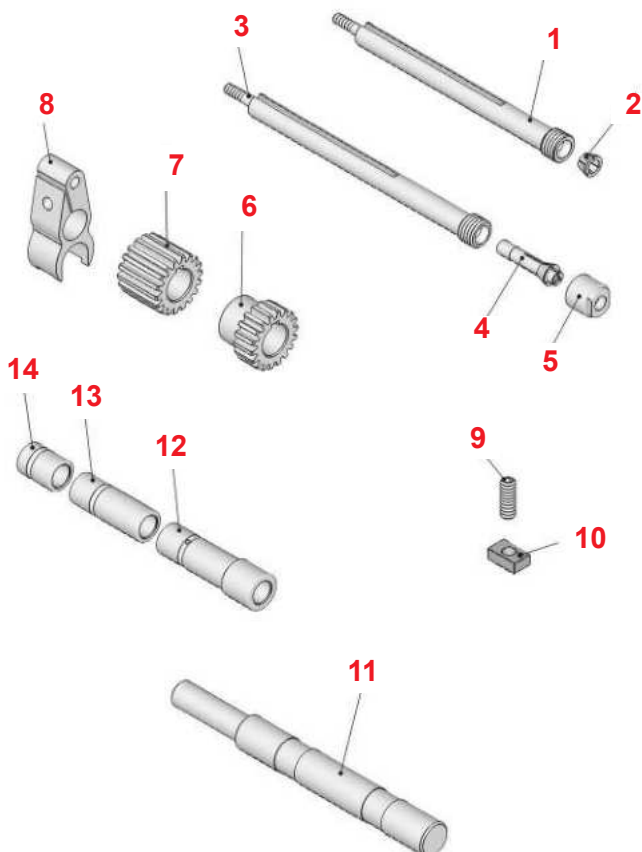

ARTIGLI PER VITE SENZA FINE STROHM 75 - 105 - 125

WORMS CLUTCH FOR STROHM 75-105-125

MACCHINA	Art.	d	D	L	f
STROHM 75 - 105 - 125	1253	16	34	15	34 x 1,5

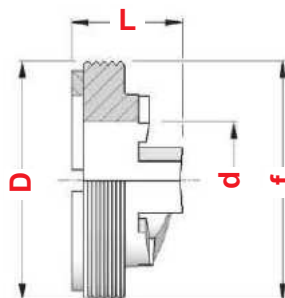

MACCHINA	Art.	d	D	L	f
STROHM 75 - 105 - 125	1254	16	24,5	21	21 x 1

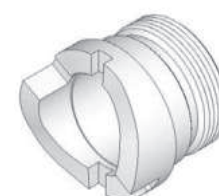
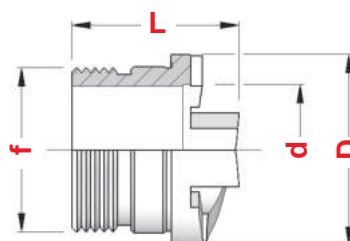

INGRANAGGI PER CAMBIO AVANZAMENTI STROHM

TRANSMISSION GEARS FOR STROHM

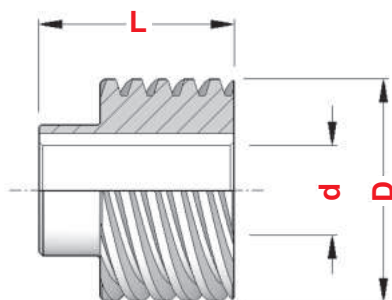

Fig. 1

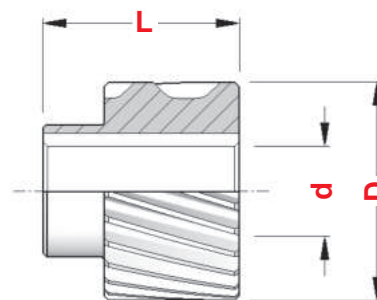

Fig. 2

VITI SENZA FINE
WORMS

MACCHINA	Art.	d	D	L	Elica	Fig.
STROHM 75 - 105 - 125	1865	25	60	52	DX	1
STROHM 205 - 255	0628	25	73	53	DX	1

CORONE
WORM WHEELS

Art.	d	D	L	Elica	Fig.
1866	25	58	52	DX	2
0634	25	72	53	DX	2

TASSELLI PER SCATTO TORRETTA INDEX

DOWELS FOR INDEX TURRET RELEASE



MACCHINA	TIPO	Art.	D	S	Figura	
INDEX 12 - 18 - 25	DESTRO - RIGHT	2410	6,5	8	2	0095
	SINISTRO - LEFT	2409	6,5	8	1	
INDEX 24 - 36 - 52	DESTRO - RIGHT	2277	8,2	10	4	0274
	SINISTRO - LEFT	2276	8,2	10	3	
INDEX 36 - 42 - 52	DESTRO - RIGHT	2279	8,2	10	2	
	SINISTRO - LEFT	2278	8,2	10	1	



Fig. 1
Sinistro
Left



Fig. 2
Destro
Right

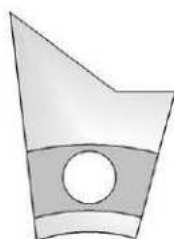

Fig. 3
Sinistro
Left

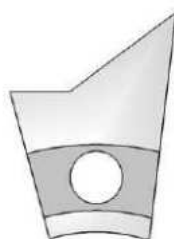
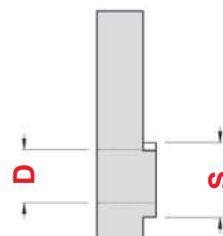
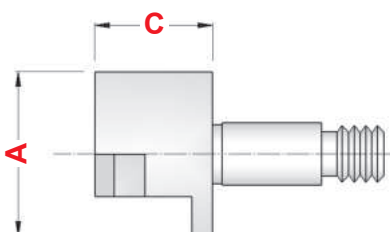
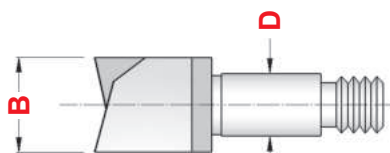

Fig. 4
Destro
Right



SELETTORI PER SCATTO TORRETTA INDEX

SELECTORS FOR INDEX TURRET RELEASE



MACCHINA	TIPO	Art.	D	A	B	C
INDEX 12 - 18 - 25	3/6 SCATTI - 3/6 SPRINGS	0270	8	21	12	15
INDEX C.19 - 29	3/6 SCATTI - 3/6 SPRINGS	2678	10	18	14	18
INDEX 36 - 52	3/6 SCATTI - 3/6 SPRINGS	2677	10	24	14	18
INDEX B.30 - 42 - 60	3/6 SCATTI - 3/6 SPRINGS	2678	10	18	14	18

APPUNTI / NOTES

Handwriting practice area consisting of 30 horizontal dotted lines.





Stabilimento di Bologna - Reparti produttivi
Factory in Bologna - Production departments



REG. N. 2072
UNI EN ISO 9001:2015

Gait®

dal
1960

I dati tecnici indicati a catalogo
possono essere modificati anche senza preavviso
ed alcun obbligo di aggiornamento

*The technical data indicated in the catalog
may be revised even without notice
and any obligation to update*



E' possibile scaricare il Certificato del Sistema di Gestione
per la qualità dal nostro sito www.gait.it

*It is possible to download the Certificate of
Quality Management System from our website*

Copyright 2022

Gait® srl

Tutti i diritti riservati



Foto e disegni protetti da diritto d'autore
È vietata ogni riproduzione

Photos and drawings protected by copyright
Any reproduction is prohibited